

LECTURE NOTES
ON
TOOL ENGINEERING

**Ganesh Institute of Engineering and
Technology**



SCTE &VT, BHUBANESWAR
ODISHA

4th Semester Diploma in Mechanical Engineering
(As per Syllabus prescribed by SCTE&VT, Odisha)

By

Subject Coordinator: Er. Jyotiranjana Paikray

LECTURER, MECHANICAL ENGINEERING

UNIT I

THEORY OF METAL CUTTING

Mechanics of chip formation, single point cutting tool, forces in machining, Types of chip, cutting tools – nomenclature, orthogonal metal cutting, thermal aspects, cutting tool materials, tool wear, tool life, surface finish, cutting fluids and Machinability.

METAL REMOVAL PROCESSES:

1. Discuss the mechanics of chip removal process?

When the tool advances into the work piece, the metal in front of the tool is severely stressed. The cutting tool produces internal shearing action in the metal. So the metal below the cutting edge yields and flows plastically in the form of chip. The removal of metal from work piece in the form of chips is called as metal removal process.

2. List the various metal removal machineries. (AU Apr 2011)

The various metal removal machineries are:

- i) Turning machines
- ii) Drilling machines
- iii) Boring machines
- iv) Milling machines
- v) Grinding machines

Specialized variations depending upon the requirement are:

- i) Automats
- ii) Copy turning machines
- iii) Form relieving lathes
- iv) Reaming

MECHANICS OF CHIP FORMATION

3. Write on cutting tools.

A cutting tool may be used either for cutting a part or for removing chips.

1. Single point tools:

It is performed by cutting tools having distinct cutting edge. They find a wide application on lathes and slotting machines.

2. Multi point tools:

These are two or more single point tools arranged together as a unit. Example: Milling and broaching tool.

4. Define cutting or shaping process.

The required shape of metal is obtained by removing the unwanted material from the work piece in the form of chips is called cutting or shaping. Example: Turning, Drilling, Milling, Boring etc.

5. Write down the various metal removing machineries according to relative motions between work piece and cutting tool.

- (i) Rotation of work against the tool. Example: Turning Machine.
- (ii) Rotation of tool against work piece. Example: Drilling, Milling machine
- (iii) Linear movement of the work piece against the tool. Example: Planer machine
- (iv) Linear movement of the tool against the work. Example: Shaper machine

6. Classify the various angles in cutting tool?

The various angles in cutting tools are:

- 1) Back rake angle
- 2) Side rake angle
- 3) End relief angle
- 4) Side relief angle
- 5) Side cutting angle
- 6) End cutting angle.

7. Classify the types of metal cutting process.

The metal cutting processes are mainly classified into two types.

- a. Orthogonal cutting process (two dimensional cutting)
- b. Oblique cutting process (Three dimensional cutting)

8. Define orthogonal and oblique cutting.

Orthogonal cutting: - The cutting edge of tool is perpendicular to the direction of tool travel.

Oblique cutting: - The cutting edge is inclined at an acute angle (less than 90°) with normal to the direction of tool travel is called oblique cutting process.

9. Compare orthogonal and oblique cutting. (AU Dec 2010) (AU Apr 2010) (April/May 2015)

Orthogonal Metal Cutting	Oblique Metal Cutting
Cutting edge of the tool is perpendicular to the direction of tool travel.	The cutting edge is inclined at an angle less than 90° to the direction of tool travel.
The direction of chip flow is perpendicular to the cutting edge.	The chip flows on the tool face making an angle.
The chip coils in a tight flat spiral	The chip flows sideways in a long curl.
For same feed and depth of cut the force which shears the metal acts on a smaller areas. So the life of the tool is less.	The cutting force acts on larger area and so tool life is more.
Produces sharp corners	Produces a chamfer at the end of the cut
Smaller length of cutting edge is in contact with the work.	For the same depth of cut greater length of cutting edge is in contact with the work.

10. Draw the chip flow in orthogonal cutting.

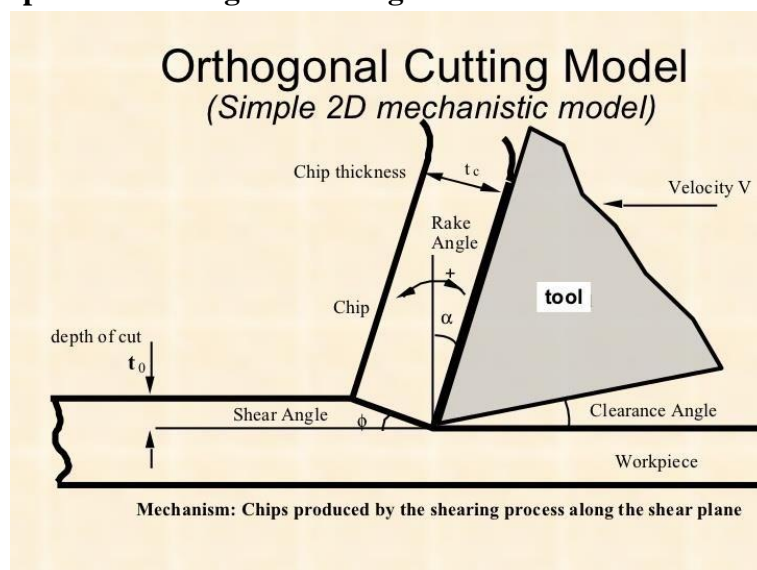

11. Draw the chip flow in oblique cutting.

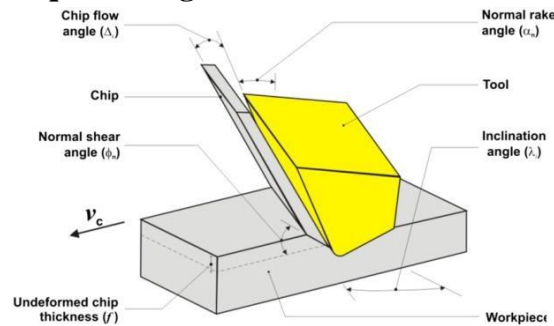

12. How chip formation occurs in metal cutting? (AU Apr 2011)

- ❖ When the tool advances into the work piece, the metal in front of the tool is severely stressed. The cutting tool produces internal shearing action in the metal.
- ❖ The metal below the cutting edge yields and flows plastically in the form of chip.

13. What are the different types of chips formed?

Different types of chips produced during machining process:

- I. Continuous chips,
- II. Discontinuous chips and
- III. Chips with built up edge.

14. What are the favourable factors for discontinuous chip formation?

Favourable factors for discontinuous chip formation:

- a. Machining of brittle material
- b. Small rake angle
- c. Higher depth of cut
- d. Low cutting speeds
- e. Excess cutting fluid
- f. Cutting ductile material with low speed and small rake angle of the tool.

15. What is continuous chip?

- ❖ Continuous ribbon like chips consist of elements bonded firmly together without being fractured.
- ❖ The upper side of the continuous chip has small notches while the lower side which slides over the tool face is smooth and shiny.

16. Name any two conditions for continuous chip formation while machining.

- ❖ Ductile metals like mild steel, copper, etc.
- ❖ Fine feed, high cutting speed, large rake angle, keen cutting edge, smooth tool Face.
- ❖ Efficient lubrication system is favourable for this form of chip.

17. When will the continuous chip be formed?

The following factor favors the formation of continuous chip.

- (i) Ductile material
- (ii) Smaller depth of cut
- (iii) High cutting speed
- (iv) Large rake angle
- (v) Sharp cutting edge
- (vi) Proper cutting fluid

(vii) Low friction between tool face and chips.

18. How can built up edge formed during machining be avoided?

The built-up edges formed during machining can be avoided by:

- Improving the lubrication conditions
- Usage of sharp tools
- Using better surface finish tool
- Applying ultrasonic vibration during the machining process.

19. What is meant by built up edge?(Nov –Dec 2012)

The term built up edge implies the building up of a ridge of metal on the top surface of the tool and above the cutting edge.

20. What are the factors responsible for built-up edge in cutting tools? (AU Dec 2009)

Factors responsible the formation of buildup edge is:

- Low cutting speed
- Low rake angle
- High feed
- Large depth of cut.

21. What are the favourable factors for continuous chip with built up edge?

The favourable factors for continuous chip with built up edge:

- a. Low cutting speed.
- b. Small rake angle.
- c. Course feed.
- d. Strong adhesion between chip and tool face.
- e. Insufficient cutting fluid.

22. What is chip thickness ratio?

The ratio of chip thickness before cutting (t_1) to chip thickness after cutting (t_2) is called as chip thickness ratio.

Chip thickness ratio (r) = —

23. What is chip reduction co-efficient?

The reciprocal of chip thickness ratio is called chip reduction co-efficient.

$$\text{Chip reduction co efficient} = \frac{1}{\text{chip thickness ratio}}$$

24. What is the problem encountered due to long and continuous chip?

During machining, long and continuous chip that are formed at high cutting speed will affect machining. It will spoil tool, work and machine. These chips are hard, sharp and hot. So, the disposal of chip is difficult.

25. Classify the different types of chip breakers?

The chip breakers are classified into three types.
a. Step type. b. Groove type. c. Clamp type.

26. What is the function of chip breakers? (AU Dec 2006, Noc 2010)

The function of chip breakers is to reduce the radius of curvature of chips and thus break the continuous chip into small discontinuous chip.

CUTTING TOOL NOMENCLATURE:

27. Draw the nomenclature of cutting tool.

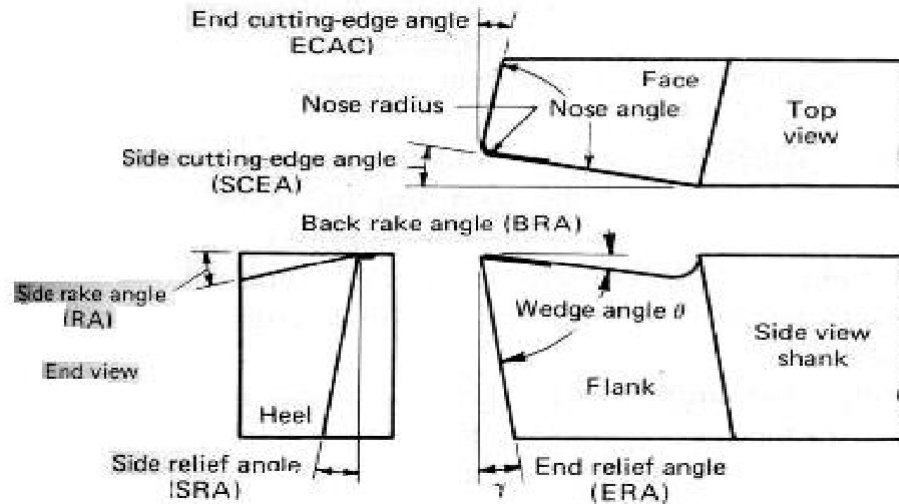

28. Define :i) Shank ii) Face iii) Flank iv) Heel

i) Shank :

The shank is the portion of the tool bit which is not ground to form cutting edges and is rectangular in cross section.

ii) Face :

Face of the cutting tool is the surface against which the chip slides upward.

iii) Flank:

Flank of the cutting tool is the surface which faces the work piece.

iv) Heel :

The Heel of a single point tool is the lowest portion of the side cutting edges.

29. What is clearance angle? Also mention its types?

Clearance Angle:

Clearance angle is the angle between the flank or front face of the tool and a tangent to the work surface originating at the cutting edge.

The clearance angle can be classified into two types:

1. Side clearance or side relief angle
2. End clearance or end relief angle.

30. What does Side clearance or side relief indicate?

- Side clearance or side relief is a type of the clearance angle.
- Side clearance or side relief indicates that the plane that forms the flank or side of a tool has been ground back at an angle sloping down from the side cutting edge.

31. What does End clearance or end relief indicate?

- End clearance or end relief is a type of clearance angle.
- End clearance or end relief indicates that the nose or end of a tool has been round back at an angle sloping down from the end cutting edge.

32. What is rake angle?

The rake is the slope of the top away from the cutting edge.

33. What is effect of back rake angle and mention the types?

Back rake angle of tool increases the strength of cutting tool and cutting action.

It can be classified into two types.

1. Positive rake angle.
2. Negative rake angle.

34. What is side rake angle? And mention its effects?(Nov 2006)

The angle between the tool face and the line, it will be parallel to the base of the tool. It is used to control chip flow. Side rake is more important than back rake for turning operations.

35. When will the negative rake angles be used?(JUNE 2013,May 2015)

Negative rake angles are used:

- a. To machine high strength alloys.
- b. The machine tools are more rigid.
- c. The feed rates are high.
- d. To give heavy and interrupted cuts.

36. What are all conditions for using positive rake angle?

Conditions for using positive rake angle:

- a. To machine the work hardened materials.
- b. To machine low strength ferrous and non-ferrous metals.
- c. To turn the long shaft of small diameters.
- d. To machine the metal below recommended cutting speeds.

37. What is tool signature?

The numerical code that describes all the key angles of a given cutting tool is called tool signature.

CUTTING FORCES IN METAL CUTTING.

38. What is cutting force?

The high compressive and frictional contact stresses on the tool face result in a substantial cutting force F . The compressive force applied to form the chip is called cutting force.

39. What are the factors that influence the cutting forces?

Cutting forces depend on the following:

- i) Material to be cut.
 - a) Hardness of material
 - b) Strength of material
- ii) Depth of cut
- iii) Feed
- iv) Tool Geometry

40. Why should cutting forces be determined?

We need to determine the cutting forces in turning for:

- Estimation of cutting power consumption
- Structural design of the machine – fixture – tool system
- Evaluation of role of the various machining parameters
- Study of behavior and machinability characterization of the work materials
- Condition monitoring of the cutting tools and machine tools.

41. What is shear plane?

The material of work piece is stressed beyond its yield point under the compressive force. This causes the material to deform plastically and shear off. The plastic flow takes place in a localized region is called shear plane.

42. What are the assumptions made by merchant circle?

- a. The chip formation will be continuous without built up edge.
- b. During cutting process cutting velocity remains constant.
- c. The cutting tool has a sharp cutting.

43. What is metal removal rate?

It is defined as the volume of metal removed in unit time. It is used to calculate time required to remove specified quantity of material from the work piece.

44. What are the assumptions made in Lee and Shaffer's theory?

- a. The work ahead of the tool behaves as ideal plastic mass.
- b. There exists a shear plane which separates the chip and work piece
- c. No hardening in chip occurs.

45. List the total energy of the cutting process.

Total energy per unit volume is approximate equal to the sum of following four energies.

- a. Shear energy in shear plane,
- b. Friction energy in tool face,
- c. Surface energy due to the formation of a new surface area in cutting.
- d. Momentum energy due to the change in momentum associated with the metal crosses the shear plane.

CUTTING TOOL MATERIALS:

46. What are the factors should be considered for selection of tool materials? (April 2015)

Factors considered for selection of tool materials:

- i. Volume of production
- ii. Tool design
- iii. Type of machining process
- iv. Physical & Chemical properties
- v. Rigidity and condition of machine.

47. What are the important characteristics of tool?

The important characteristics of tool:

- i. Hot hardness
- ii. Wear resistance
- iii. Toughness
- iv. Low friction
- v. High thermal conductivity
- vi. Resistance to thermal shock
- vii. Easy to grind and sharpen.
- viii. Higher hardness

48. Name any four tool materials.

Tool materials:

- i. Carbon tool steel
- ii. High speed steel
- iii. Cemented carbides
- iv. Ceramics
- v. Diamonds

TOOL WEAR:

49. Classify the tool wear.

The tool wear is generally classified as follows,

- ✓ Flank wear or wear land
- ✓ crater wear or Face wear
- ✓ Nose wear

50. What is Crater wear?

The crater is on the rake face and is more or less circular. The crater does not always extend to the tool tip, but it may end at a distance from the tool tip. It increases the cutting forces, modifies the tool geometry and softens the tool tip.

51. Draw the Flank wear.

Flank wear:

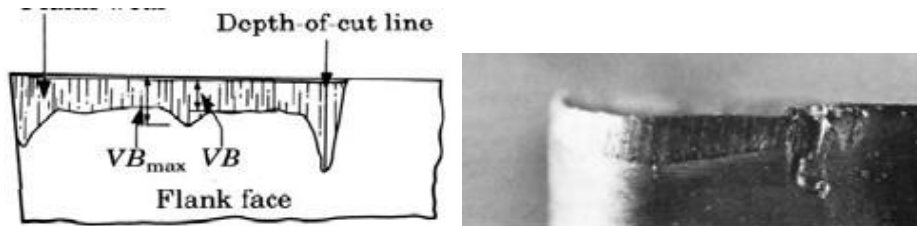

52. What is electrochemical wear in tools? (AU Dec 2009)

- Electrochemical phenomena are taking place in the cutting zone. It causes wear of cutting tools.
- The formation of freshly exposed surfaces, extremely high pressures and high temperatures in the zone of contact between the workpiece and the tool.
- All these promote electrochemical interaction between the working medium and the tool and workpiece materials causes material loss.

53. What are the parameters which affect the rate of tool wear?

Parameters, which affect the rate of tool wear, are:

- Cutting conditions (cutting speed V , feed f , depth of cut d)
- Cutting tool geometry (tool orthogonal rake angle)
- Properties of work material

TOOL LIFE:

54. How tool life is defined? (Nov 2014)

Tool life is defined as Interval of time for which tool works satisfactorily between the two successive sharpening.

55. What are the ways of representing tool life?

The following are some of the ways of expressing tool life.

- i. Volume of metal removed per grind,
- ii. Number of work piece machined per grind,
- iii. Time a tool will operate satisfactorily.

56. What are the factors affecting tool life?

- i. Cutting speed
- ii. Feed and depth of cut
- iii. Tool geometry
- iv. Tool material
- v. Cutting fluid
- vi. Work material
- vii. Rigidity of work, tool and machine.

57. Express the Taylor's tool life equation.

Taylor's tool life equation

$VT^n = C$ where,

V = Cutting speed in m/min.

T = Tool life in minute

C = Constant

n = Index depends upon tool and work.

58. What are all the factors considered for selection of cutting speed?

- i. Tool life
- ii. Properties of material being machined,
- iii. Rate of feed
- iv. Depth of cut
- v. Tool geometry.
- vi. Cutting fluid used,
- vii. Type of machining process
- viii. Surface finish to be obtained.

59. What are the tool life criteria in practice?

Tool Life Criteria in practice:

1. Complete failure of cutting edge
2. Visual inspection of flank wear (or crater wear) by the machine operator.
3. Fingernail test across cutting edge
4. Changes in sound emitted from operation
5. Chips become ribbony, stringy, and difficult to dispose of
6. Degradation of surface finish
7. Increased power
8. Work piece count
9. Cumulative cutting time

60. How do cutting tools fail?

Cutting tools generally fail by:

- ❖ Mechanical breakage due to excessive forces and shocks.
- ❖ Quick plastic deformation due to intensive stresses and temperature. This type of failure also occurs rapidly and is quite detrimental and unwanted.
- ❖ Gradual wear of the cutting tool at its flanks and rake surface.
- ❖ Due to loss of hardness
- ❖ Crumbling of the cutting edge

SURFACE FINISH:

61. What is surface texture?

The machining processes generate a wide variety of surface textures. Surface texture consists of the repetitive and/or random deviations from the ideal smooth surface.

These deviations are:

- ❖ Roughness: small, finely spaced surface irregularities (micro irregularities)
- ❖ Waviness: surface irregularities of graterspacing (macro irregularities)
- ❖ Lay: predominant direction of surface texture.

62. What are the factors that make surface roughness the most important?

Three main factors make the surface roughness.

- ✓ Fatigue life
- ✓ Bearing properties
- ✓ Wear

63. Name the factors that contribute to poor surface finish in cutting. (AU Dec 2006)

Factors, influencing surface roughness in machining are

- Tool geometry (major cutting edge angle and tool corner radius),
- Cutting conditions (cutting velocity and feed), and
- Work material properties (hardness).

64. Name the process parameter which improves surface finish.

The process parameters which improve surface finish are:

- Increasing the tool rake angle generally improves surface finish
- Higher work material hardness results in better surface finish
- Tool material has minor effect on surface finish.
- Cutting fluids affect the surface finish

CUTTING FLUIDS:

65. How are cutting fluids classified?What is its prime function?

Cutting fluids are classified as:

- i) Coolants
- ii) Lubricants.

The prime function of a cutting fluid in a metal cutting operation is to control the total heat.This can be done by dissipating the heat generated as well as reducing it.

66. What are coolants?

Cutting fluids which are water based is called coolants. Coolants reduce the heat generation at shear zone and friction zone. It has high specific heat and thermal conductivity. It is effective at high cutting speeds.

67. Name some of the cutting fluids.

The following fluids are normally used:

- Carbon tetrachloride
- Acetic acid
- Turpentine
- Kerosene
- Paraffin oil
- Soluble oil
- Water

68. What is the function of cutting fluids?

- It is used to cool the cutting tool and work piece,
- It lubricates the cutting tool and thus reduces the co-efficient of friction between tool and work,
- It improves the surface finish as stated earlier,
- It causes the chips to break up into small parts,
- It protects the finished surface from corrosion,
- It washes away the chips from the tool. It prevents the tool from fouling,

- It prevents corrosion of work and machine.

69. What are the process effects of using cutting fluids in machining?

Process effects of using cutting fluids in machining include:

- Longer Tool Life
- Reduced Thermal Deformation of Work piece
- Better Surface Finish (in some applications)
- Ease of Chip handling

70. What are the properties of cutting fluid?

- It should have good lubricant properties,
- It should high heat absorbing capacity,
- It should have a high specific heat, high heat conductivity and high film co-efficient,
- It should high flash point.
- It should be odorless,
- It should be non-corrosive to work and tool,
- It should have low viscosity to permit free flow of the liquid.

71. How are cutting fluids selected?

The selection of cutting fluids for a given application requires the examination of a number of parameters such as workpiece material, machining operation, cutting tool material and other ancillary factors.

72. Name the cutting fluid for the following materials and give its characteristics.

i) High carbon steel ii) HSS iii) Non-ferrous materials

- i) High carbon steel: Water based coolants are used generally.
- ii) HSS: For general machining, water based cutting fluid can be used. For heavy duty work EP neat oils are preferable.
- iii) Non-ferrous materials: Neat cutting oils are the most suitable choice for most applications. They should be never overcooled or subjected to intermittent cooling during a cut because they are brittle and are likely to suffer thermal shock.

MACHINABILITY:

73. Define machinability of metal.

The term machinability refers to the ease with which a metal can be machined to an acceptable surface finish.

74. What are the factors affecting the machinability?

- ❖ Chemical composition of work piece material,
- ❖ Microstructure of work piece material
- ❖ Mechanical properties like ductility, toughness etc.
- ❖ Physical properties of work materials.
- ❖ Method of production of the work materials.

75. What are all the tool variables affecting the machinability?

- ❖ Tool geometry and tool material.
- ❖ Nature of engagement of tool with the work.
- ❖ Rigidity of tool.

76. What are the machine variables affecting the machinability?

- ❖ Rigidity of machine
- ❖ Power and accuracy of the machine tool.

77. How the machinability can be evaluated?

The following criteria suggested for evaluating machinability.

- Tool life per grind,
- Rate of removal per tool grind
- Magnitude of cutting forces and power consumption. Surface finish.
- Dimensional stability of finished work.
- Heat generated during cutting.
- Ease of chip disposal.
- Chip hardness, shape and size.

78. Mention the advantage of high machinability.

- ❖ Good surface finish can be produced,
- ❖ High cutting speed can be used,
- ❖ Less power consumption,
- ❖ Metal removal rate is high,
- ❖ Less tool wear.

79. What is machinability index? (April/ May 2016)

It is a comparison of machinability of different material to standard material.
US material standard for 100% machinability is SAE 1112 hot rolled steel.

Machinability index, I = _____

PART - B

Introduction:

Theory of metal cutting consists of study of machining process and accurate estimation of dynamic cutting forces by the use of suitable analytical models.

1. Explain the Mechanism of chip removal in metal cutting process.(May 2011,May2013).

Mechanism of Chip Removal:

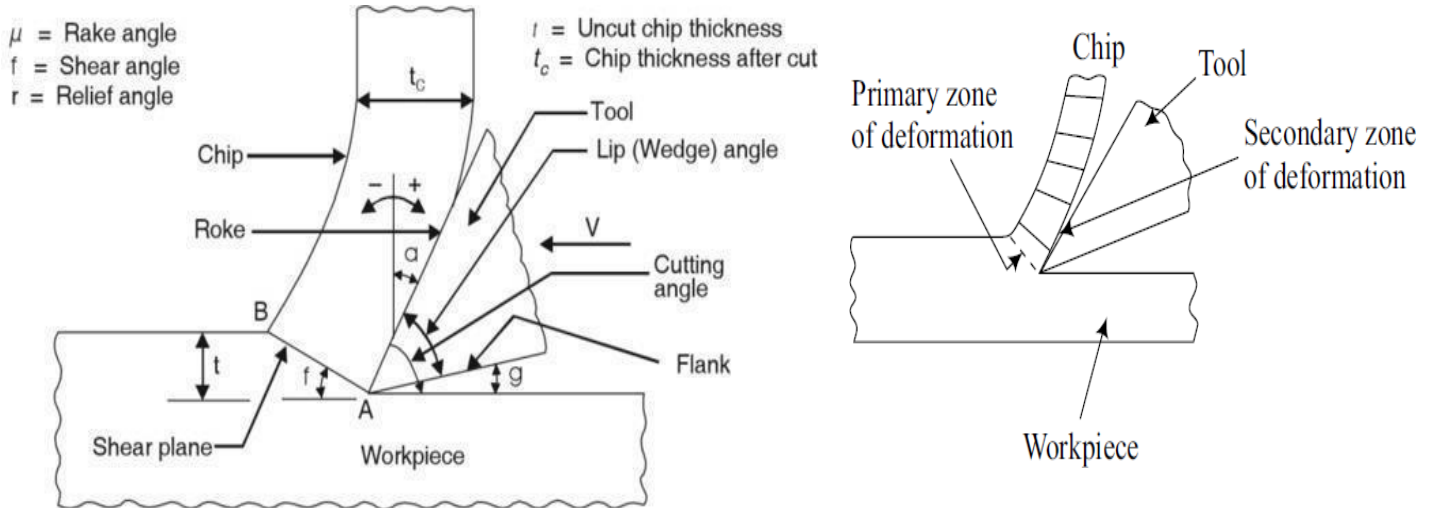

Mechanism of Chip Formation

- The tool is considered stationary, and the work pieces moves to the right.
- The metal is severely compressed in the area in the front of the cutting tool.
- This causes high temperature shear and plastic flow if the metal is ductile.
- When the stress in the work piece just ahead of the cutting tool reaches a value exceeding the ultimate strength of the metal, particles will shear to form a chip element which moves up along the face of the work.
- The outward or shearing movement of each successive element is arrested by work hardening and the movement transferred to the next element.
- The process is repetitive and a continuous chip is formed having a highly compressed and the burnished underside, and a minutely serrated top side caused by the shearing action.
- The place along which the element shears is called the shear plane.
- Thus the chip is formed by plastic deformation of the grain structure of the metal along the shear plane.

2. Explain the various types of chips in detail. (Nov.2005, Nov.2006, Nov.2007, Nov.2008, Nov.2010, May 2011)

Types of chips:

- I. Continuous chips
- II. Continuous chips with built-up edge
- III. Discontinuous chips
- IV. Segmented chips

I. Continuous Chip

- ❖ During cutting of ductile material, a continuous ribbon like chip is produced due to the pressure of the tool cutting edge in compression and shear.
- ❖ These types of chips are in the form of long coil and have the same thickness throughout the length. The below figure shows the continuous chip formation.
- ❖ This type of chip is most required, since it give the advantage of good surface finish, improving the tool life and less power consumption. However chip disposal is not easy and the surface finish of the finished work gets affected.

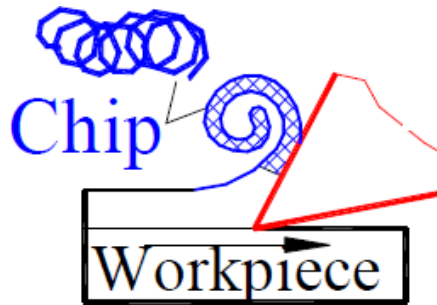

The following condition favours the formation of continuous chips.

- ❖ Ductile material such as low carbon steel, aluminium, copper etc.
- ❖ Smaller depth of cut.
- ❖ High cutting speed.
- ❖ Large rake angle.
- ❖ Sharp cutting edge.
- ❖ Proper cutting fluid.
- ❖ Low friction between tool face and the chips.

II. Continuous Chip with Built-up Edge:

- ❖ During cutting process the interface temperature and pressure are quite high and also high friction between tool-chip interface.
- ❖ It causes the chip material to weld itself to the tool face near the nose is called built –up edge.
- ❖ Formation of a built –up edge in continuous chip is a transient and not stable phenomenon .the accumulated build-up edge of chip material will then break away,part adhering to the underside of the chip and part to the work piece.
- ❖ Thus, the process gives rise to a poor surface finish on the machined surface and accelerated wears on the tool face.
- ❖ However, this type of chips having some advantages, the one importance favour of it is that, the

rake face of the tool protected from wear due to moving chips and the action of heat. It may result the increasing of tool life.

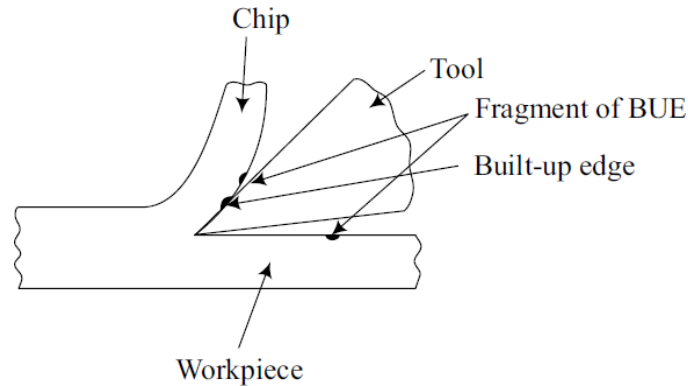

The following conditions favour the formation of discontinuous chips;

- ❖ Low cutting speed.
- ❖ Small rake angle.
- ❖ Strong adhesion between chips and tool face.
- ❖ Insufficient cutting fluid.
- ❖ Large uncut thickness

III. Discontinuous Chip

- Discontinuous chips as shown in figure are produced while machining brittle materials such as grey cast iron, bronze, high carbon steel at low cutting speeds without fluids when friction exists between the tool and chips interface.
- During machining, the brittle material lacks its ductility which is necessary for plastic chip formation. But, it should be less .It results the formation of discontinuous chip.
- In the case of continuous chip, the formation shearing occurs at head of the cutting tool continuously without fracture whereas in discontinuous chip formation, the rupture occurs intermittently which will produce segments of chips. The figure shows the discontinuous chip formation.
- Handling of these chips is easier and it can be easily disposed off since they are having small lengths .also, it will not spoil the finished work surface as they do not interfere.

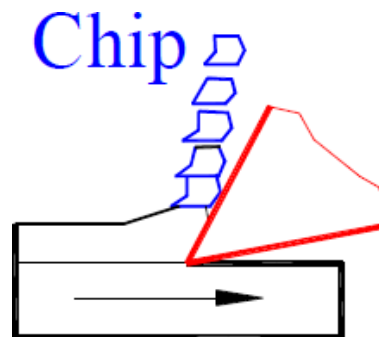

The following conditions the formation of discontinuous chips

- ❖ Machining of brittle material.
- ❖ Small rake angle.
- ❖ Higher depth of cut.
- ❖ Low cutting fluid.

- ❖ Excess cutting fluid.
- ❖ Cutting ductile material at very low feeds with small rake angle of the tool

IV. Segmented Chip

During machining of most engineering materials, segmented chips are produced, which are a combination of continuous chips and discontinuous chips. The shape of these chips depends upon rake angle, cutting speed and material properties.

3. Explain the function of chip breaker and also discuss various types of chip breakers in detail. (Nov.2008)

Chip breakers:

Need and purpose of chip-breaking:

Continuous machining like turning of ductile metals, unlike brittle metals (like grey cast iron), produce continuous chips, which leads to their handling and disposal problems. The problems become acute when ductile but strong metals like steels are machined at high cutting velocity for high MRR by flat rake face type carbide or ceramic inserts. The sharp edged hot continuous chip that comes out at very high speed:

- ❖ Becomes dangerous to the operator and the other people working in the vicinity.
- ❖ May impair the finished surface by entangling with the rotating job.
- ❖ Creates difficulties in chip disposal.

Therefore it is essentially needed to break such continuous chips into small regular pieces for:

- ❖ Safety of the working people.
- ❖ Prevention of damage of the product.
- ❖ Easy collection and disposal of chips.
- ❖ Chip breaking is done also for the additional purpose of improving machinability by reducing the chip-tool contact area, cutting forces and crater wear of the cutting tool.

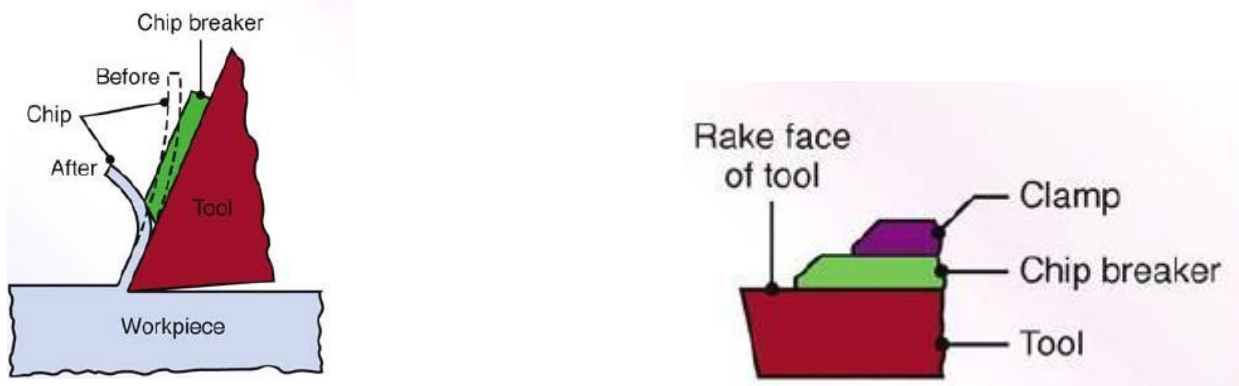

Figure : chip breaker

The principles and methods of chip breaking are generally classified as follows:

a. Self-chip breaking:

This is accomplished without using a separate chip-breaker either as an attachment or an additional geometrical modification of the tool.

b. Forced chip breaking:

This is accomplished by additional tool geometrical features or devices.

Chip breakers are basically of two types:

1. In-built type chip breaker
 - ❖ Step type in-built chip breaker
 1. Parallel step.
 2. Angular step; positive and negative type.
 3. Parallel step with nose radius - for heavy cuts
 4. Negative angular
 - ❖ Groove type in-built chip breaker
 1. Circular groove.
 2. Tilted V groove.
2. Clamped or attachment type

In-built breakers:

These are in the form of step or groove at the rake surface near the cutting edges of the tools. Such chip breakers are provided either

- ❖ After their manufacture – in case of HSS tools like drills, milling cutters, broaches etc. and brazed type carbide inserts
- ❖ During their manufacture by powder metallurgical process – e.g., throw away type inserts of carbides, ceramics and cermets.

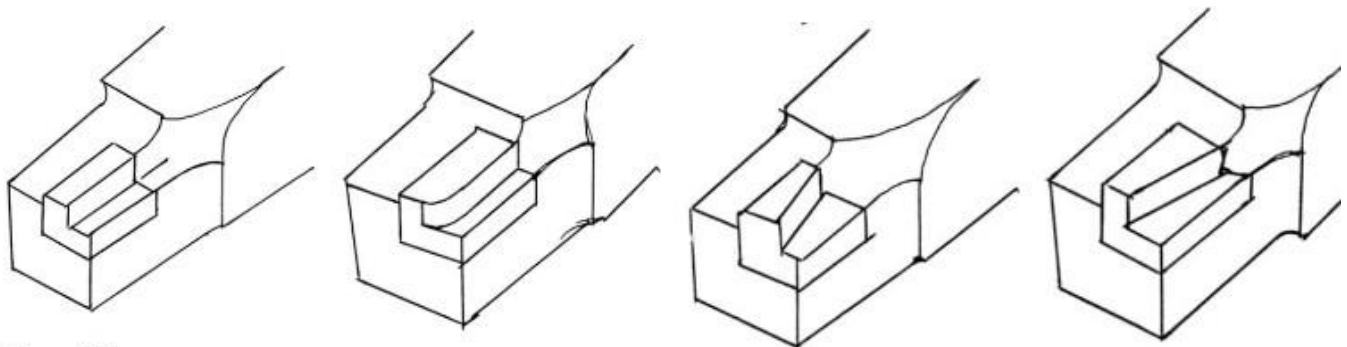

(a) Parallel step

(b) Parallel and radiused

(c) Positive angular

(d) Negative angular

Step type in-built chip breaker

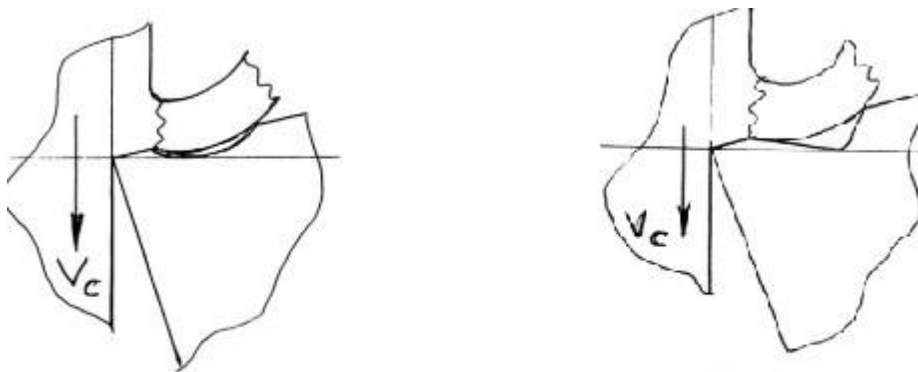

(a) Circular groove

(b) Tilted V-groove

Groove type in-built chip breaker

The unique characteristics of in-built chip breakers are:

- ❖ The outer end of the step or groove acts as the heel that forcibly bend and fracture the running chip
- ❖ Simple in configuration, easy manufacture and inexpensive
- ❖ The geometry of the chip-breaking features are fixed once made (i.e., cannot be controlled)
- ❖ Effective only for fixed range of speed and feed for any given tool-work combination.

Clamped type chip-breaker:

Clamped type chip breakers work basically in the principle of stepped type chip-breaker but have the provision of varying the width of the step and the angle of the heel.

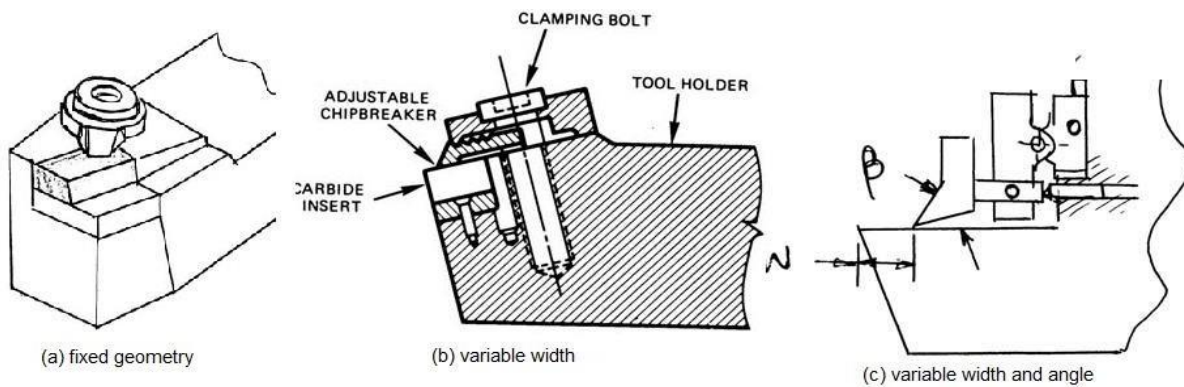

Cutting Tools:

The cutting tools may be classified in different ways. Depending upon the number of cutting points on the tool, the cutting tools are of two types:

1. Single-point cutting tools,
2. Multi-point cutting tools.

A single-point cutting tool has only one cutting point or edge. The tools used for turning, boring, shaping, or planing operations, that is, tools used on lathes, boring machines, shaper, planer, etc. are single point tools.

A multi-point tool has two or more than two cutting [for example, tools used on drilling machines, milling machines, broaching machines etc. multi-point tool can be considered to be basically a series of single-point tools.

4. Explain the Nomenclature of single point cutting tool. (Nov 2007, Nov 2009),

Single point cutting tool nomenclature:

In tool geometry the various tool angle are listed and then describe bellow with neat sketch.

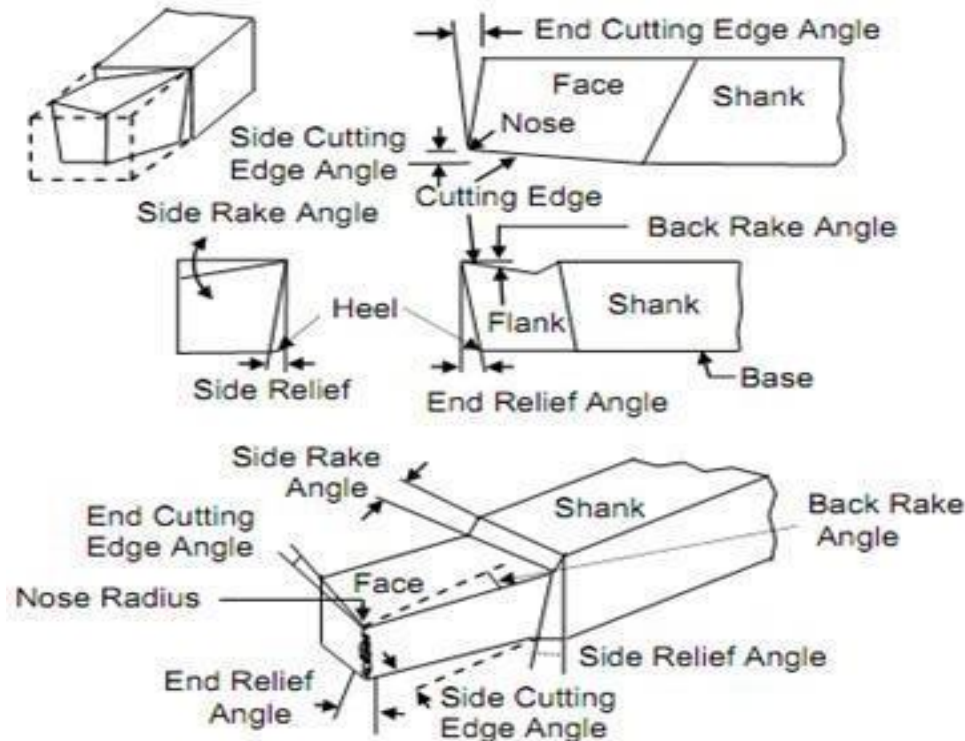

Single point cutting tool nomenclature

a) Tool Terminology:

1. **Shank:** Main body of tool, it is part of tool which is gripped in tool holder
2. **Face:** Top surface of tool b/w shank and point of tool. Chips flow along this surface
3. **Flank:** Portion tool which faces the work. It is surface adjacent to & below the cutting edge when tool lies in a horizontal position.
4. **Point:** Wedge shaped portion where face & flank of tool meet.
5. **Base:** Bearing surface of tool on which it is held in a tool holder.
6. **Heel:** The Heel of a single point tool is the lowest portion of the side cutting edges.
7. **Nose radius:** Cutting tip, which carries a sharp cutting point. Nose provided with radius to enable greater strength, increase tool life & surface life.

Typical Value: 0.4 mm – 1.6 mm

b) Important angles of cutting tool:

- i. **Side Cutting Edge Angle (SCEA):** It is also known as lead angle (C_s) and approach angle. It is the angle between the side cutting edge and side of the tool shank.
- ii. **End Cutting Edge Angle (ECEA):** This is the angle between the end cutting edge and the normal to the tool shank.
- iii. **Side Relief Angle (SRA):** It is the angle between the portion of the side flank immediately below the side cutting edge and a line perpendicular to the base of the tool and measured at right to the side flank.

- iv. **End Relief Angle (ERA):** It is the angle between the portion of the end flank immediately below the end cutting edge and a line perpendicular to the base of the tool and measured at a right angle to the end flank.
- v. **Back Rake Angle (BRA):** It is the angle between the tool face and line parallel to the base of the tool and measured in a plane (perpendicular) through the side cutting edge. This angle is positive.
- vi. **Side Rake Angle (SRA):** It is the angle between the tool face and a line parallel to the base of the tool and measured in a plane perpendicular to the base and the side cutting.

5. Explain the Orthogonal Rake system in metal cutting and American Standards Association (ASA) system. (Nov 2008)

Orthogonal Rake System (ORS):

As mentioned above in this system, the planes for designating tool are the planes containing the principal or side cutting edge and the plane normal on it.

In the plane NN, which is normal to the principle cutting edge and is known as orthogonal plane or chief plane, we have the following angles: side relief angles γ , the side rake angle (orthogonal rake angle) α wedge angle (lip angle) and cutting angle

Side relief angle is the angle between the side main flank and the cutting plane. The side rake angle, α , is the angle between the toolface and a plane normal to the cutting plane and passing through the main cutting edge.

The wedge angle β is the angle between the tool face and the main flank. The cutting angle δ is the angle between the tool face and the cutting plane. When α is positive we have $\alpha + \gamma + \text{wedge angle} = 90^\circ$ so $\gamma + \beta = \delta$. The usual value α and γ are $\alpha = -10^\circ$ to $+15^\circ$, $\gamma = 6^\circ$ to 12° .

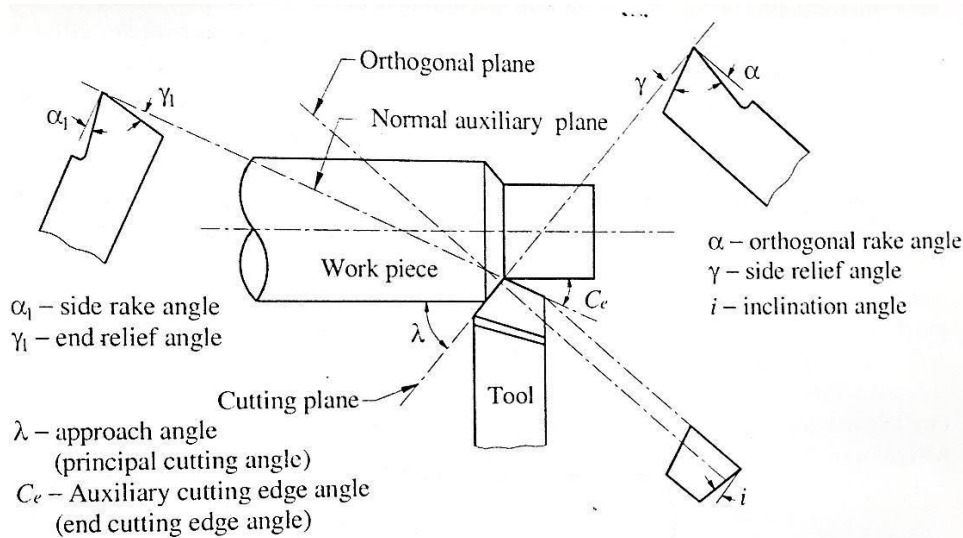

The angles are also measured in the plane (known as auxiliary reference plane) which is normal to the projection of the end cutting edge on the basic plane. These angles are end relief angle γ_1 and back rake angle α_1 (also called auxiliary rake angle).

The plane angles are the approach angle or entering angle λ which is equal to $(90^\circ - C_s)$ and the end cutting edge angle C_e .

Tool Designation under ORS is:

$$i - \alpha - \gamma - \gamma_1 - C_e - \lambda - R$$

i = inclination angle

α = Orthogonal rake angle

α_1 = side rake angle

γ = side relief angle

γ_1 = end relief angle

λ = Approach angle (principal cutting edge angle)

C_e = End cutting edge angle (auxiliary cutting edge angle)

EXAMPLE 1.

In a single point cutting tool used for turning the geometry as per ASA is:

Bake Rake Angle = 8°

Side Rake Angle = 4°

Side cutting edge angle = 15°

Find the Values of Inclination angle and rake angle in ORS tool nomenclature.

SOLUTION:

Given Data,

As per the ASA system

Bake Rake Angle $\alpha_b = 8^\circ$

Side Rake Angle $\alpha_s = 4^\circ$

Side cutting edge angle $C_s = 15^\circ$

In ORS nomenclature

λ = approach angle

= $90^\circ - C_s$

= $90^\circ - 15^\circ$

= 75°

By using conversion equation

Orthogonal Rake Angle

$$\tan \alpha = \tan \alpha_s \sin \lambda + \tan \alpha_b \cos \lambda$$

$$= \tan 4^\circ \sin 75^\circ + \tan 8^\circ \cos 75^\circ$$

$$\underline{\alpha = 5.56^\circ}$$

Inclination Angle

$$\begin{aligned} \tan i &= -\tan \alpha_s \cos \lambda + \tan \alpha_b \sin \lambda \\ &= -\tan 4^\circ \cos 75^\circ + \tan 8^\circ \sin 75^\circ \\ \tan i &= 75^\circ \end{aligned}$$

American Standards Association (ASA) system: utilizes three mutually perpendicular planes of reference in order to measure various angles of a Single Point Turning Tool. These three planes are:

- **Reference Plane (π_R)**—It is a plane perpendicular to the cutting velocity vector (V_c).
- **Machine Longitudinal Plane (π_X)**—It is a plane perpendicular to reference plane (π_R) and along the direction of longitudinal feed for turning operation.
- **Machine Transverse Plane (π_Y)**—It is a plane perpendicular to reference plane (π_R) and along the direction of transverse feed for turning operation.

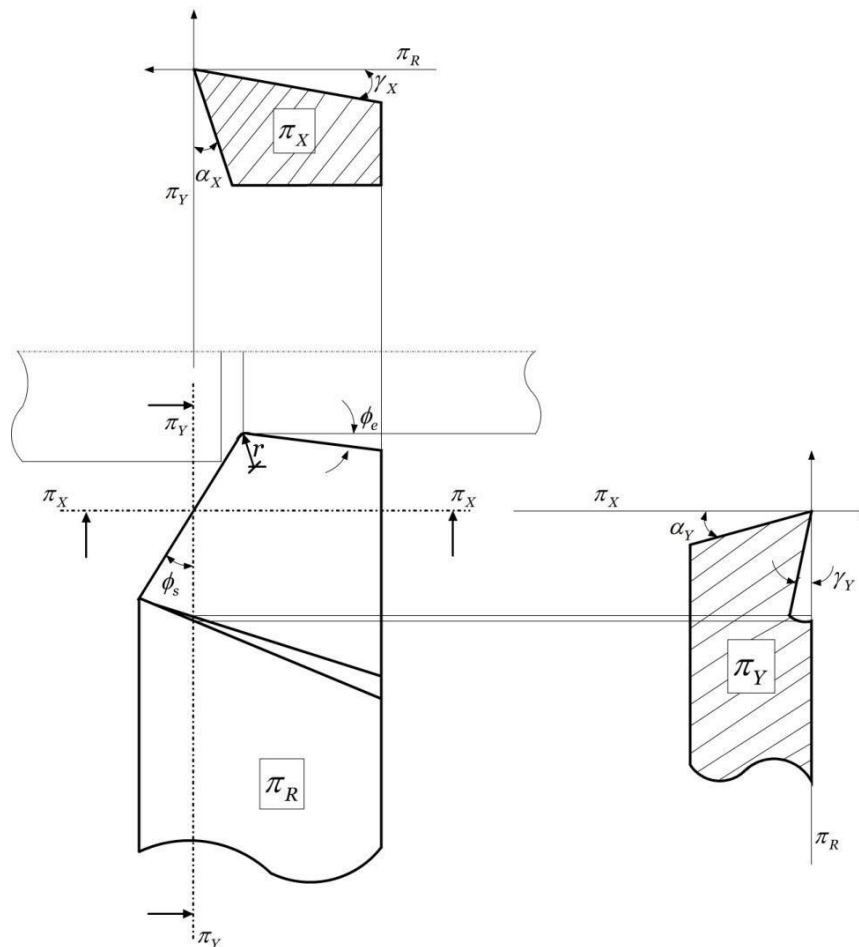

Various tool angles for designation of turning tool in ASA system

Various Features Displayed in ASA System of Tool Designation:

In turning operation, longitudinal feed provides required feed (s) motion, which is measured in mm/rev. So it indicates length of travel of the cutting tool per unit revolution of the cylindrical work piece. On the other hand, transverse feed provides required depth of cut (t) in mm per pass. Now, the ASA system of tool designation specifies the two different rake angles, two different clearance angles, two different cutting edge angles, and the nose radius value in inch. Various features of a single point turning tool (SPTT) that ASA system displays are provided below.

- **Side Rake Angle (γ_X)**—It is the angle of orientation of tool's rake surface from the reference plane (π_R) and measured on machine longitudinal plane (π_X).
- **Back Rake Angle (γ_Y)**—It is the angle of orientation of tool's rake surface from the reference plane (π_R) and measured on machine transverse plane (π_Y).
- **Side Clearance Angle (α_X)**—It is the angle of orientation of tool's principal flank surface from the cutting velocity vector (V_c) and measured on machine longitudinal plane (π_X).
- **Back Clearance Angle (α_Y)**—It is the angle of orientation of tool's principal flank surface from the cutting velocity vector (V_c) and measured on machine transverse plane (π_Y).
- **Approach Angle (Φ_s)**—It is the angle between principal cutting edge and the machine transverse plane (π_Y), measured on reference plane (π_R).
- **End Cutting Edge Angle (Φ_e)**—It is the angle between auxiliary cutting edge and the machine longitudinal plane (π_X), measured on reference plane (π_R).
- **Nose Radius (r)**—This is nothing but the curvature at the tool tip. It is to be noted that in ASA system, nose radius value is expressed in inch.

Style of Designation of a Turning Tool by ASA System (Tool Signature):

Designation of Single Point Turning Tool (SPTT) by American Standards Association (ASA) system.

The seven features of the cutting tool are specified as shown above. The sequence of designation should be followed strictly. However, different people may use different notations for various angles maintaining the original sequence unchanged. For an example, a typical turning tool can be specified in ASA system as:

Designation of Single Point Turning Tool (SPTT) by American Standards Association (ASA) system

$\gamma_Y; \gamma_X; \alpha_Y; \alpha_X; \Phi_e; \Phi_s; r$ (inch)

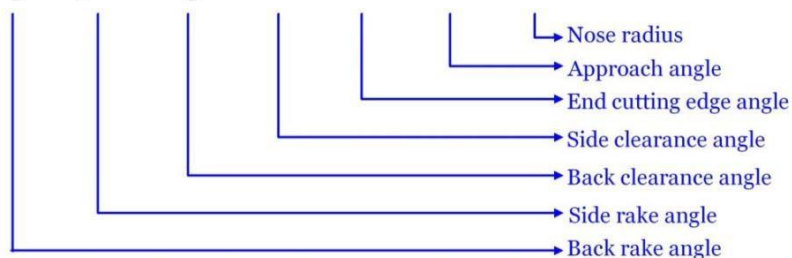

–8°, 12°, 5°, 10°, 15°, 30°, 1/8 (inch)

Therefore, upon interpretation, we may write:

- Back Rake Angle (γ_Y) = 8°
- Side Rake Angle (γ_X) = 12°
- Back Clearance Angle (α_Y) = 5°
- Side Clearance Angle (α_X) = 10°
- End Cutting Edge Angle (Φ_e) = 15°
- Approach Angle (Φ_s) = 30°
- Nose Radius (r) = 1/8 inch

6. Explain the Orthogonal and Oblique metal cutting with neat sketch. (May 2010)

Differentiate Orthogonal and Oblique metal Cutting.

Orthogonal and Oblique metal Cutting:

Basically there are two methods of metal cutting depending upon the arrangement of the cutting edge with respect to the direction of the relative work tool motion.

- Orthogonal Cutting or Two Dimensional Cutting.
- Oblique cutting or three dimensional cutting.

a. Orthogonal Cutting

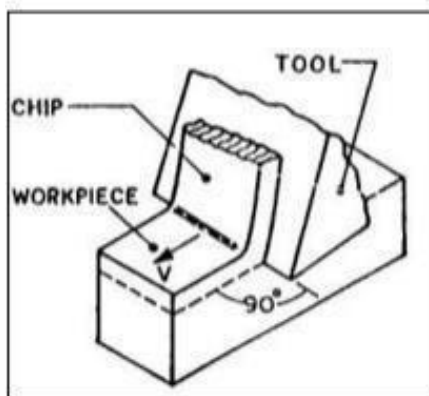

b. Oblique Cutting

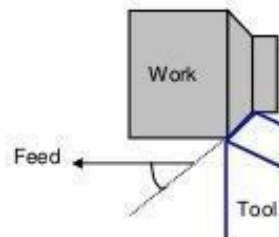
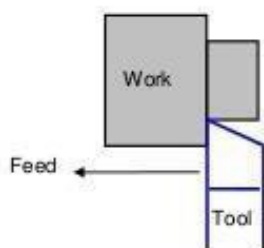
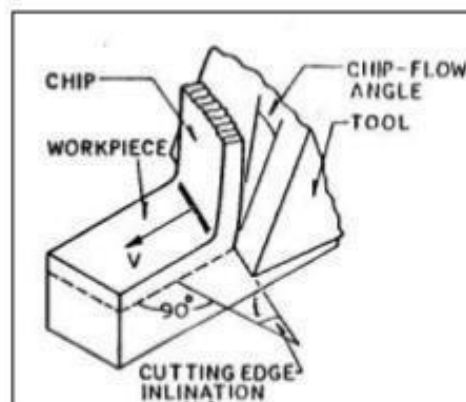

The differences between orthogonal and oblique cutting is given below

S.No	Orthogonal metal cutting	Oblique metal cutting
1.	Cutting edge of the tool is perpendicular to the direction of tool travel.	The cutting edge is inclined at an angle less than 90° to the direction of tool travel.
2.	The direction of chip flow is perpendicular to the cutting edge.	The chip flows on the tool face making an angle.
3.	The chip coils in a tight flat spiral	The chip flows sideways in a long curl.
4.	For same feed and depth of cut the force which shears the metal acts on a smaller areas. So the life of the tool is less.	The cutting force acts on larger area and so tool life is more.
5.	Produces sharp corners.	Produces a chamfer at the end of the cut
6.	Smaller length of cutting edge is in contact with the work.	For the same depth of cut greater length of cutting edge is in contact with the work.
7.	Generally parting off in lathe, broaching and slotting operations are done in this method.	This method of cutting is used in almost all machining operations.

7. Derive the relationship between shear angle and chip thickness ratio. (Nov.2005, Nov.2010).

Determination of Shear Angle:

In the simplified model of two dimensional cutting operations, the cutting tool is completely defined by the rake angle α and clearance angle γ . In additions the following assumptions are made

1. Tool is perfectly sharp and contacts the chip on its front or rake face.
2. The primary deformation takes place in a very thin zone adjacent to the shear plane AB.
3. There is no flow of chip that is plain strain condition.

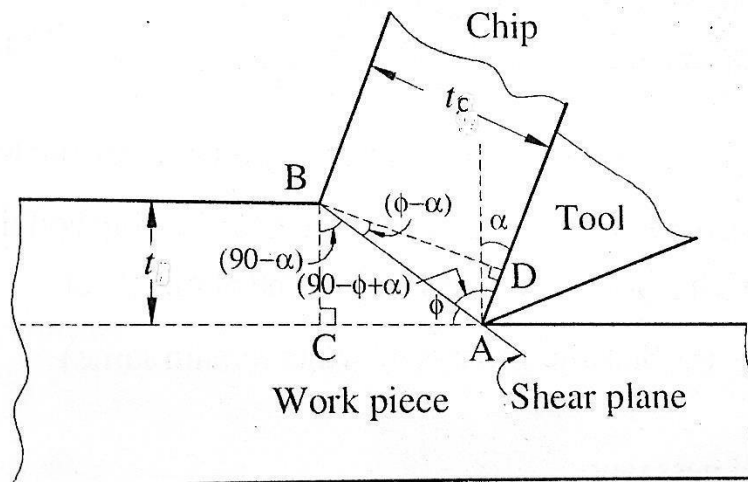

Shear angle α is defined as the angle made by the shear plane with the direction of the tool travel if

t = uncut chip or un-deformed chip thickness.

t_c = chip thickness after the metal is cut.

ϕ = Shear Angle.

α = Rake Angle.

The shear angle can be determined in the following ways.

From equation of continuity,

$$t \cdot b \cdot v = t_c \cdot b_c \cdot v_c \text{-----(1)}$$

Where, t = depth of cut, b = width of cut, v = cutting velocity

t_c = chip thickness b_c = width of chip v_c = chip velocity

In most cutting processes, $b = b_c$

$$t \cdot v = t_c \cdot v_c \text{-----(2)}$$

The chip thickness ratio,

$$r_t = \frac{t}{t_c} = \frac{v_c}{v} = \frac{L_c}{L}$$

where, L = uncut chip length

L_c = length of chip formed.

From the length of shear plane

$$\frac{t}{\sin \phi} = \frac{t_c}{\cos (\phi - \alpha)}$$

$$r_t = \frac{t}{t_c} = \frac{\sin \phi}{\cos (\phi - \alpha)}$$

$$r_t \cos (\phi - \alpha) = \sin \phi$$

$$r_t (\cos \phi \cos \alpha + \sin \phi \sin \alpha) = \sin \phi$$

Divide above equation by $\cos \phi$ we get

$$r_t \cos \alpha + r_t \tan \phi \sin \alpha = \tan \phi$$

$$r_t \cos \alpha = \tan \phi - r_t \tan \phi \sin \alpha$$

$$r_t \cos \alpha = \tan \phi (1 - r_t \sin \alpha)$$

$$\tan \phi = \frac{r_t \cos \alpha}{1 - r_t \sin \alpha}$$

Chip velocity:

The chip velocity along the tool rake face, V_c is the vector sum of velocity of uncut chip V and the velocity discontinuity along the shear plane.

$$\vec{V}_c = \vec{V}_t + \vec{V}_s$$

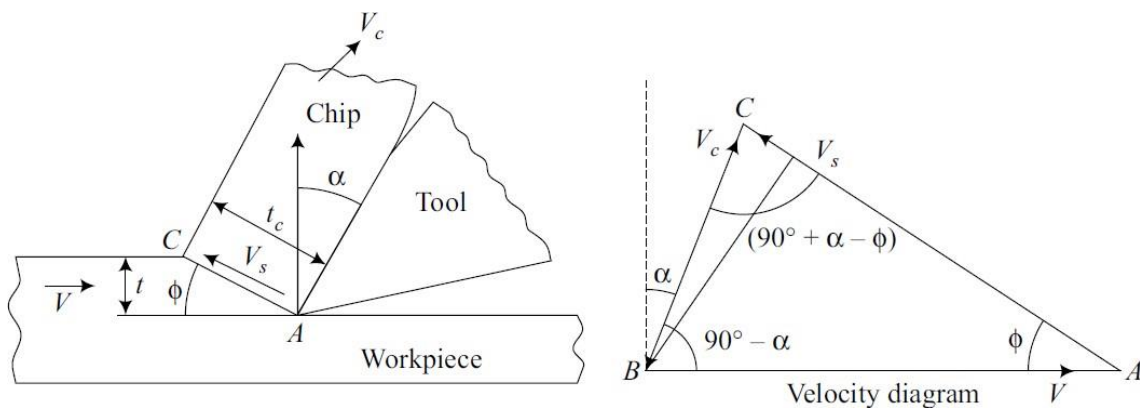

From velocity triangle BAC , using Lami's theorem,

$$\frac{V}{\sin (90^\circ + \alpha - \phi)} = \frac{V_s}{\sin (90^\circ - \alpha)} = \frac{V_c}{\sin \phi}$$

Problem 1.

The end of a pipe was orthogonally cut with a tool of 20° rake angle. The chip length was measured as 85 mm whereas uncut chip length was 202 mm. Determine shear plane angle and chip thickness if depth of cut was 0.5 mm. (May 2016)

Solution: Assume, the chip width b_c = width of uncut chip, b = Chip length, $L_c = 85$ mm

Length of uncut chip $L = 202$ mm

$$\text{Chip thickness ratio } r_t = \frac{L_c}{L} = \frac{85}{202} = 0.42$$

$$= \frac{0.42 \cos 20^\circ}{1 - 0.42 \sin 20^\circ}$$

Shear plane angle, $\phi = 27.4^\circ$

$$\text{Chip thickness, } t_c = \frac{t}{r_i} = \frac{0.5}{0.42} = 1.19 \text{ mm}$$

Problem 2. A specimen of 100 mm length along the stroke of a shaper is machined with 15° rake angle tool. Determine the shear plane angle and chip thickness if uncut chip thickness is 1.5 mm and chip length obtained is 40 mm.

Solution: Assuming that there is no change in the width of chip during machining,

$$t \times L = t_c \times L_c$$

$$\therefore \text{Chip thickness ratio, } r_i = \frac{t}{t_c} = \frac{L_c}{L} = \frac{40}{100} = 0.4.$$

$$\begin{aligned} \tan \phi &= \frac{r_i \cos \alpha}{1 - r_i \sin \alpha} \\ &= \frac{0.4 \cos 15^\circ}{1 - 0.4 \sin 15^\circ} \end{aligned}$$

Shear plane angle, $\phi = 25.8^\circ$

$$\text{Chip thickness, } t_c = \frac{t}{r_i} = \frac{1.5}{0.4} = 3.75 \text{ mm}$$

8. Explain the force relationship in orthogonal cutting. (Nov.2008, May 2008)

Describe the Merchants model for orthogonal metal cutting. (May 2015).

Force relationship in machining:

Here the analysis is limited to two dimensional or orthogonal cutting which is simpler to understand as compared to the complicated three dimensional cutting process when a cut is made. The force acting on metal chip are,

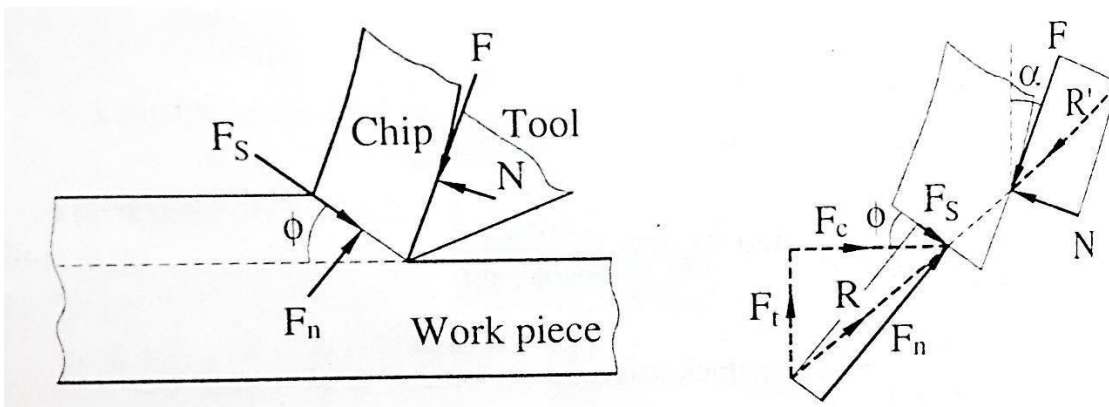

- F_s which is resistance to shear of the metal is forming the chip its act along shear plane.
- F_n which is Normal to the shear plane. This is backing up force on the chip provided by the work piece.
- $F =$ It is the frictional resistance of the tool acting on chip. It acts downward against the motion of the chip as it glides upwards along the tool face.
- $N =$ It is the force subjected at the tool chip interface acting normal to the cutting face of the tool and is provided by the tool.

The free body diagram showing the forces acting on chip. R is the resultant force of F and N and R' that of F_s and F_n , Neglecting the couple which curl the chip. Considering the equilibrium of the chip, R and R' are equal in magnitude opposite in direction and collinear.

Merchant force circle:

All the forces related to metal cutting can be represented with the help of a circle known as the 'merchant force circle'.

- In figure the two force triangle have been superimposed by placing the two equal forces R and R' together.
- In the figure β is the angle of friction. In this diagram for convenience, the resultant force have been moved to the point of the tool.
- Since the forces F_s and F_n are at right angle to each other, their intersection lies on circle with diameter R' .
- The two orthogonal components (horizontal and vertical) F_c and F_t of the resultant force R' can be measured by using tool dynamometer.
- The thrust force F_t does not contribute the work done. It holds the tool against the work piece.
- By knowing F_c , F_t , α , ϕ , all the component force acting on the chip can be determined with help for merchant force circle.

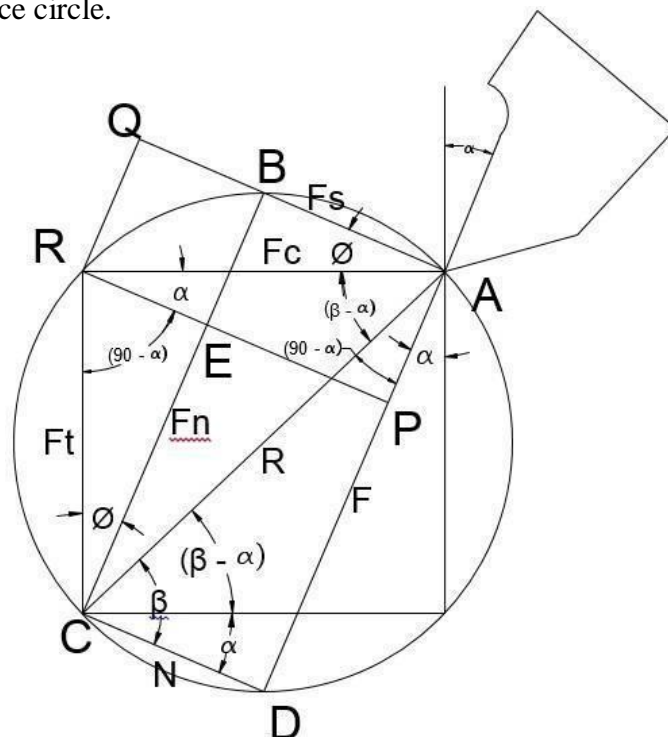

Determination of F_s :

$F_s = AB$
 $= AQ - QB$

Considering ΔAQR and finding $AQ = F_c \cos \phi$

ΔREC and finding $QB = RE = F_t \sin \phi$

$F_s = F_c \cos \phi - F_t \sin \phi$ (i)

Determination of F_n :

$F_n = BC$
 $= BE + EC$

Considering ΔAQR and finding $BE = RQ = F_c \sin \phi$ ΔREC

and finding $EC = F_t \cos \phi$

$F_n = F_c \sin \phi + F_t \cos \phi$ (ii)

Determination of F :

$F = AD$
 $= AP + PD = AP + SC$

Considering ΔRPA and finding $AP = F_c \sin \alpha$

ΔRSC and finding $SC = F_t \sin (90 - \alpha) = F_t \cos \alpha$

$F = F_c \sin \alpha + F_t \cos \alpha$ (iii)

Determination of N :

$N = CD = PS$
 $= PR - RS$

Considering ΔRPA and finding $RP = F_c \cos \alpha$

ΔRSC and finding $RS = F_t \cos (90 - \alpha) = F_t \sin \alpha$

$N = F_c \cos \alpha - F_t \sin \alpha$ (iv)

From triangle ΔADC

If average coefficient of friction between the chip and tool is μ .

$$\mu = \tan \beta = \frac{F_t}{F_n}$$

Also $\tan (\beta - \alpha) = \frac{F_v}{F_h}$

Shear strain in machining can be computed from the following equation, based on the preceding parallel plate model:

$\gamma = \tan(\phi - \alpha) + \cot \phi$

where γ = shear strain, ϕ = shear plane angle, and α = rake angle of cutting tool

Shear stress acting along the shear plane:

$$\sigma = \frac{F_s}{A_s}$$

where A_s = area of the shear plane

$$A_s = \frac{t_o W}{\sin \phi}$$

The power to perform machining can be computed from:

$$P_c = F_c v$$

where P_c = cutting power; F_c = cutting force; and v = cutting speed

MERCHANT THEORY:

Merchant's model for orthogonal cutting is based on the following assumptions.

1. The tool edge is sharp.
2. The shear plane is thin.
3. The deformation is in two dimensions only.
4. The normal and shear stresses are distributed uniformly on the shear plane.
5. The work material is rigid and perfectly plastic.

Merchant equation:

From all the possible angles at which shear deformation could occur, the work material will select a shear plane angle ϕ which minimizes energy, given by

$$\phi = 45 + \frac{\alpha}{2} - \frac{\beta}{2}$$

Where,

= shear angle

α = Rake angle

β = friction angle

9. How do the flank wear affect the tool life?

Tool life:

- ❖ Tool wear is a time dependent process. As cutting proceeds, the amount of tool wear increases gradually. But tool wear must not be allowed to go beyond a certain limit in order to avoid tool failure.

- ❖ The most important wear type from the process point of view is the flank wear, therefore the parameter which has to be controlled is the width of flank wear land, V_B . This parameter must not exceed an initially set safe limit, which is about 0.4 mm for carbide cutting tools.
- ❖ The safe limit is referred to as allowable wear land (wear criterion), V_{B_k} .
- ❖ The cutting time required for the cutting tool to develop a flank wear land of width V_{B_k} is called tool life, T , a fundamental parameter in machining.
- ❖ The general relationship of V_B versus cutting time is shown in the figure (so-called wear curve). Although the wear curve shown is for flank wear, a similar relationship occurs for other wear types. The figure shows also how to define the tool life T for a given wear criterion V_{B_k} .

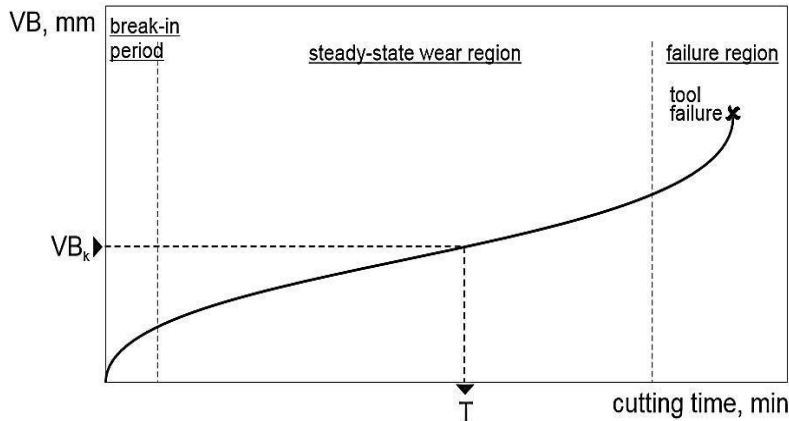

Fig: Flank wear as a function of cutting time

- ❖ The slope of the wear curve (that is the intensity of tool wear) depends on the same parameters, which affect the cutting temperature as the wear of cutting tool materials is a process extremely temperature dependent.
- ❖ Parameters, which affect the rate of tool wear are cutting speed V , feed f , depth of cut d , cutting tool geometry (rake angle) and properties of work material.
- ❖ From all these parameters, cutting speed is the most important one. As cutting speed increases, wear rate increases, so the same wear criterion is reached in less time, i.e., tool life decreases with cutting speed.

10. Discuss the Taylor's tool life equation in detail. (May 2007)

Taylor tool life equation:

If the tool life values for the three wear curves are plotted on a natural log-log graph of cutting speed versus tool life as shown in the right figure, the resulting relationship is a straight line expressed in equation form is called the Taylor tool life equation:

$$VT^n = C$$

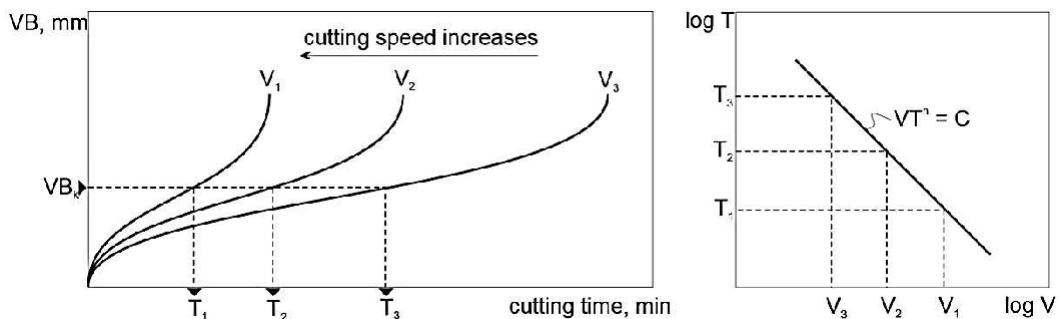

Fig. Effect of cutting speed on wear land width and tool life for three cutting speeds. Natural log-log plot of cutting speed versus tool life.

Where n and C are constants, whose values depend on cutting conditions, work and tool material properties, and tool geometry. These constants are well tabulated and easily available.

An expanded version of Taylor equation can be formulated to include the effect of feed, depth of cut and even work material properties.

Tool life also depends to a great extent on the depth of cut (d) and feed rate per revolution (f). Assuming a logarithmic variation C with d the equation can be written as,

$$V T^n d^m = C$$

V = cutting speed m/min

T = Tool life min

d = depth of cut mm

It has been seen that decrease of life with increase speed is twice as a great as the decrease of life with increased feed.

By considering feed rate also, the general equation can be written as:

$$V T^n d^m f^x = C$$

Problem 3: When Machining at 50 m/min the tool life noted as 100 min. Calculate the tool life if a similar tool cuts at 20% higher speed also find out the cutting speed if the tool is required to machine for 170 min without failing. Take $n = 0.27$ in Taylor's tool life equation. (May 2008)

SOLUTION:

Given Data,

Cutting speed (V) = 50 m/min

Tool life (T) = 100 min

Tool life index $n = 0.27$

(i) **Cutting speed if tool cuts at 20% higher speed** $V_1 = 1.2 V = 1.2 \times 50 = 60$ m/min

(ii) **Tool life if the tool is required to machine for 170 min** $T_2 = 170$ min

According to Taylor's tool life equation,

$$VT^n = C$$

$$50 \times 100^{0.27} = C$$

$$C = 173.36$$

Calculation of tool life and cutting speed if similar tool cuts at 20% higher speed

$$V_1 = 1.2 \times 50 = 60 \text{ m/min}$$

$$V_1 T_1^n = C$$

$$V_1 T_1^{0.27} = 173.36$$

$$T_1 = 50.90 \text{ min}$$

Now finding cutting velocity V_2 ,

$$V_2 T_2^n = C$$

$$V_2 = 43.32 \text{ m/min}$$

Problem.4: In a Machining test the following values of tool life observed,

V in m/s	T in Min
0.4	32
1.1	1.6

Find the value of coefficient n and C of Taylor's tool life equation and also find the cutting speed if the tool life is 60 min. (Nov 2005, Nov 2010, June 2013, May 2015)

SOLUTION:

Given Data,

$$\begin{aligned} \text{Cutting velocity } V_1 &= 0.4 \text{ m/sec} \\ &= 24 \text{ m/min} \end{aligned}$$

$$\begin{aligned} \text{Cutting velocity } V_2 &= 1.1 \text{ m/sec} \\ &= 66 \text{ m/min} \end{aligned}$$

$$\text{Tool life } T_1 = 32 \text{ min}$$

$$\text{Tool life } T_2 = 1.6 \text{ min}$$

$$\text{Tool life } T_3 = 60 \text{ min}$$

According to Taylor's tool life equation,

$$V_1 T_1^n = V_2 T_2^n = C$$

$$n = 0.337$$

By putting value of n in Taylor's equation we get coefficient C ,

$$24 \times 32^{0.337} = C$$

$$C = 77.169$$

For cutting velocity at 60 min tool life

$$V_3 T_3^n = C$$

$$V_3 60^{0.337} = 77.169$$

$$V_3 = 19.41 \text{ m/min}$$

Cutting Tool Materials:

Cutting tool is a device used to remove unwanted material from the given work piece.

11. What are the essential characters of tool material? (May 2008)

Characteristics of a cutting tool material:

- The material should be harder than the workpiece, so that it is able to penetrate into the workpiece. It should have hot hardness i.e. the ability of material to retain hardness at elevated temperatures.
- The coefficient of friction at the tool chip interface should be low for better surface finish and less wear.
- The material should have wear resistance to prevent wear and tear of the cutting tool surface.
- It should be chemically stable so that it does not react with the workpiece and chemically inert so that there is no oxidation and hence no scales and pits are formed on the surface.
- The material must have sufficient strength and toughness to withstand shocks and vibrations.
- The thermal conductivity should be high, so that there is heat dissipation which is generated during the machining process thereby increasing the life of the cutting tool.

Hot HARDNESS

The material must remain harder than the work material at elevated operating temperatures.

TOUGHNESS

Ability of the material to absorb energy or vibration during machining without failing. Cutting is often accompanied by impact forces especially if cutting is interrupted, and cutting tool may fail very soon if it is not strong enough.

WEAR RESISTANCE

The material must withstand excessive wear even though the relative hardness of the tool-work materials changes.

LOW FRICTION

The co-efficient of friction at the chip - tool interface must remain low for minimum wear and reasonable surface finish

Ease of fabrication and COST OF TOOL

The cost and the easeness of fabrication should be reasonable.

12. Explain the various cutting tool materials in detail.(May 2011,June 2013)

Common cutting tool material used:

i. Carbon steel:

- Carbon steels having carbon percentage as high as 1.5% are used as tool materials.
- However they are not able to withstand very high temperature and hence they are operational at low cutting speed. These are the oldest of the tool materials dating back hundreds of years.
- In simple terms it is a high carbon steel (steel which contains about 0.9 to 1.3% carbon). Inexpensive, easily shaped, sharpened. No sufficient hardness and wear resistance. Limited to low cutting speed operation.

ii. **High speed steel (HSS):**

- These are special alloy steel which are obtained by alloying tungsten, Chromium, Vanadium, Cobalt and molybdenum with steel.
 - HSS has high hot hardness, wear resistance and 3 to 4 times higher cutting speed as compare to carbon steel. Most commonly used HSS have following compositions.
 - The major difference between high speed tool steel and plain high carbon steel is the addition of alloying elements (manganese, chromium, tungsten, vanadium, molybdenum, cobalt, and niobium) to harden and strengthen the steel and make it more resistant to heat (hot hardness).
 - They are of two types: Tungsten HSS (denoted by T), Molybdenum HSS (denoted by M).
- a) 18-4-1 HSS i.e. 18% tungsten, 4% chromium, 1% vanadium with a carbon content of 0.6 - 0.7%. If vanadium is 2% it becomes 18-4-2 HSS.
- b) Cobalt high speed steel: This is also referred to as super high speed steel. Cobalt is added 2 – 15%. The most common composition is tungsten 20%, 4% chromium, 2% vanadium and 12% cobalt.
- c) Molybdenum high speed steel: It contains 6% tungsten, 6% molybdenum, 4% chromium and 2% vanadium.

iii. **Cemented carbide:**

- These are basically carbon cemented together by a binder. It is a powder metallurgy product and the binder mostly used is cobalt.
- The basic ingredient is tungsten carbide-82%, titanium carbide-10% and cobalt-8%. These materials possess high hardness and wear resistance and it has cutting speed 6 times higher than high speed steel (HSS).
- These tools are produced by powder metallurgy. Carbide tools are basically of three types: tungsten carbide (WC), tantalum carbide (TaC), and titanium carbide (TiC).
- The carbides or combined carbides are mixed with a binder of cobalt. They are able to retain hardness to a temperature of about 1000⁰C. So they can be used at high speeds.
- Carbide tool are available as brazed tip tools (carbide tip is brazed to steel tool) and inserts (inserts are of various shapes- triangular, square diamond and round).

iv. **Ceramics:**

- It mainly consists of aluminum oxide (Al_2O_3) and silicon nitride (Si_3N_4). Ceramic cutting tools are hard with high hot hardness and do not react with the workpiece.
- They can be used at elevated temperature and cutting speed 4 times that of cemented carbide. These have low heat conductivity.

- Non-metallic materials made of pure Aluminum oxide by powder metallurgy. The application ceramic cutting tools are limited because of their extreme brittleness.
- The transverse rupture strength (TRS) is very low. This means that they will fracture more easily when making heavy interrupted cuts. However, the strength of ceramics under compression is much higher than HSS and carbide tools. It has high hot hardness (up to 1200 degree C), so capable of running at high speeds.

v. Cast cobalt alloys or Stellites:

- It is a non-ferrous alloy consisting mainly of cobalt, tungsten and chromium (38% to 53% Cobalt, 30% to 33% Chromium, and 4% to 20% Tungsten).
- Other elements added in varying proportions are molybdenum, manganese, silicon and carbon.
- It has good shock and wear resistance properties and retains its harness up to 9000C. Stellite tools can operate at speed about 25% higher than that of HSS tools.

vi. Diamond:

- It is the hardest known material having cutting speed 15 times greater than that for high speed tools. They are of two types - industrial grade natural diamonds, and synthetic polycrystalline diamonds.
- Because diamonds are pure carbon, they have an affinity for the carbon of ferrous metals. Therefore, they can only be used on non-ferrous metals.
- Feeds should be very light and high speeds Rigidity in the machine tool and the setup is very critical because of the extreme hardness and brittleness of diamond.

vii. Cubic boron nitride (CBN):

- It is the second hardest material after diamond and a economical alternative to the later.
- It is manufactured through high temperature and pressure to bond boron crystals in cubic form with a ceramic or metal binder to form polycrystalline structure with nitride particles present.
- It is an excellent cutting tool material because it combines extreme high hot hardness up to high temperatures of 2000°C.

13. Explain the basic requirements of cutting fluid. (Nov.2009)

Characteristics of Good Cutting Fluid

- ❖ Good cooling capacity
- ❖ Rust resistance
- ❖ Good lubricating qualities

- ❖ Nontoxic
- ❖ Resistance to rancidity
- ❖ Transparent
- ❖ Relatively low viscosity
- ❖ Nonflammable
- ❖ Stability (long life)

14. Explain the various types of cutting fluids. (May 2008, June 2013).

Types of Cutting Fluids

Most commonly used cutting fluids either aqueous based solutions or cutting oils. Cutting Fluids fall into three categories

- a) Cutting oils
- b) Emulsifiable oils
- c) Chemical (synthetic) cutting fluids

a) Cutting Oils

- Oils (also called straight oils), including mineral, animal, vegetable, compounded, and synthetic oils, typically are used for low-speed operations where temperature rise is not significant.
- There are two classifications Active and Inactive.
- Terms relate to oil's chemical activity or ability to react with metal surface
- Elevated temperatures
- Improve cutting action
- Protect surface

(i) Active Cutting Oils

These Oils will darken copper strip immersed for 3 hours at temperature of 212°F.

This kind of oil has three categories

- ❖ Sulfurized mineral oils
- ❖ Sulfochlorinated mineral oils
- ❖ Sulfochlorinated fatty oil blends

(ii) Inactive Cutting Oils

These Oils will not darken copper strip immersed in them for 3 hours at 212°F.

This kind of oil has four general categories

- ❖ Straight mineral oils,
- ❖ fatty oils,
- ❖ fatty and mineral oil blends,
- ❖ sulfurized fatty-mineral oil blend

b) Emulsifiable (Water Soluble) Oils

- ❖ Emulsions (also called soluble oils), a mixture of oil and water and additives, generally are used for high-speed operations because the temperature rise is significant. The presence of

water makes emulsions highly effective coolants. The presence of oil reduces or eliminates the tendency of water to cause oxidation.

- ❖ Mineral oils containing soap like material that makes them soluble in water and causes them to adhere to work piece.
- ❖ Good cooling and lubricating qualities.
- ❖ It is used at high cutting speeds and low cutting pressures

c). Chemical Cutting Fluids

- ❖ Also called synthetic fluids Introduced about 1945 and have Stable, preformed emulsions. It contains very little oil and mix easily with water and Extreme-pressure (EP) lubricants added.
- ❖ It reacts with freshly machined metal under heat and pressure of a cut to form solid lubricant. It also reduces heat of friction and heat caused by plastic deformation of metal.
- ❖ Semi-synthetics are chemical emulsions containing little mineral oil, diluted in water, and with additives that reduce the size of oil particles, making them more effective. 4. Synthetics are chemicals with additives, diluted in water, and containing no oil.

**General Recommendations for Cutting Fluids for Machining
(see also Section 33.7)**

Material	Type of fluid
Aluminum	D, MO, E, MO + FO, CSN
Beryllium	MC, E, CSN
Copper	D, E, CSN, MO + FO
Magnesium	D, MO, MO + FO
Nickel	MC, E, CSN
Refractory metals	MC, E, EP
Steels	
Carbon and low-alloy	D, MO, E, CSN, EP
Stainless	D, MO, E, CSN
Titanium	CSN, EP, MO
Zinc	C, MC, E, CSN
Zirconium	D, E, CSN

Note: CSN = chemicals and synthetics; D = dry; E = emulsion; EP = extreme pressure; FO = fatty oil; and MO = mineral oil.

15. State the functions of cutting fluids? (May 2008)

Functions of a Cutting Fluid

Prime functions

- I. Provide cooling
- II. Provide lubrication

Other functions

- III. Prolong cutting-tool life
- IV. Provide rust control
- V. Resist rancidity

I. Functions of a Cutting Fluid: Cooling

- ❖ Heat has definite bearing on cutting-tool wear
- ❖ Small reduction will greatly extend tool life
- ❖ Two sources of heat during cutting action
- ❖ Plastic deformation of metal
- ❖ Occurs immediately ahead of cutting tool
- ❖ Accounts for 2/3 to 3/4 of heat
- ❖ Friction from chip sliding along cutting-tool face
- ❖ Water most effective for reducing heat by will promote oxidation (rust)
- ❖ Decrease the temperature at the chip-tool interface by 50 degrees F, and it will increase tool life by up to 5 times.

II. Functions of a Cutting Fluid: Lubrication

- ❖ Reduces friction between chip and tool face
- ❖ Shear plane becomes shorter
- ❖ Area where plastic deformation occurs correspondingly smaller
- ❖ Extreme-pressure lubricants reduce amount of heat-producing friction
- ❖ Extreme Pressure chemicals of synthetic fluids combine chemically with sheared metal of chip to form solid compounds (allow chip to slide)

III. Cutting-Tool Life

- ❖ Heat and friction prime causes of cutting-tool breakdown
- ❖ Reduce temperature by as little as 50°F, life of cutting tool increases fivefold
- ❖ Built-up edge
- ❖ Pieces of metal weld themselves to tool face
- ❖ Becomes large and flat along tool face, effective rake angle of cutting tool decreased

IV. Built-up Edge

- ❖ Built-up edge keeps breaking off and re-forming
- ❖ Result is poor surface finish, excessive flank wear, and cratering of tool face

V. Cutting Fluid's Effect on Cutting Tool Action

- ❖ Lowers heat created by plastic deformation of metal
- ❖ Friction at chip-tool interface decreased
- ❖ Less power is required for machining because of reduced friction
- ❖ Prevents built-up edge from forming.
- ❖ Surface finish of work greatly improved.

Cutting Fluid Effects in Machining

The primary functions of cutting fluids in machining are:

1. Lubricating the cutting process primarily at low cutting speeds
2. Cooling the work piece primarily at high cutting speeds
3. Flushing chips away from the cutting zone
4. Secondary functions include:
5. Corrosion protection of the machined surface
6. enabling part handling by cooling the hot surface

7. process effects of using cutting fluids in machining include
8. Longer Tool Life
9. Reduced Thermal Deformation of Workpiece
10. Better Surface Finish (in some applications)

16. What are the factors to be considered for selecting a cutting fluid? (May 2009)

Cutting Fluid Selection:

The principal criteria for selection of a cutting fluid for a given machining operation are:

1. Process performance
2. Corrosion inhibition
3. Heat transfer performance
4. Cost Performance
5. Chip flushing
6. Environmental Performance
7. Fluid mist generation
8. Health Hazard Performance
9. Fluid carry-off in chips

SURFACE FINISH:

a) Surface texture

The machining processes generate a wide variety of surface textures. Surface texture consists of the repetitive and/or random deviations from the ideal smooth surface.

These deviations are:

- ❖ **roughness:** small, finely spaced surface irregularities (micro irregularities)
- ❖ **waviness:** surface irregularities of greater spacing (macro irregularities)
- ❖ **Lay: predominant direction of surface texture.**

b) Influence of surface roughness:

- ❖ **Fatigue life:** the service life of a component under cyclic stress (fatigue life) is much shorter if the surface roughness is high
- ❖ **Bearing properties:** a perfectly smooth surface is not a good bearing because it cannot maintain a lubricating film.
- ❖ **Wear:** high surface roughness will result in more intensive surface wear in friction. Surface finish is evaluated quantitatively by the average roughness height, Ra.

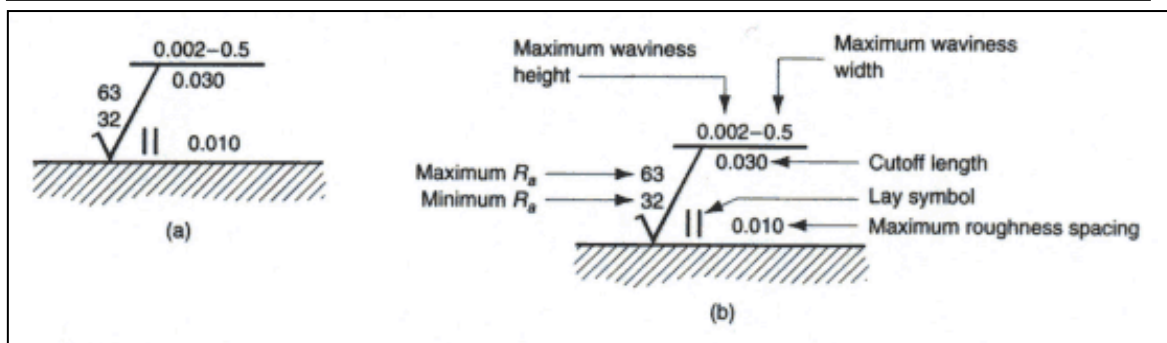
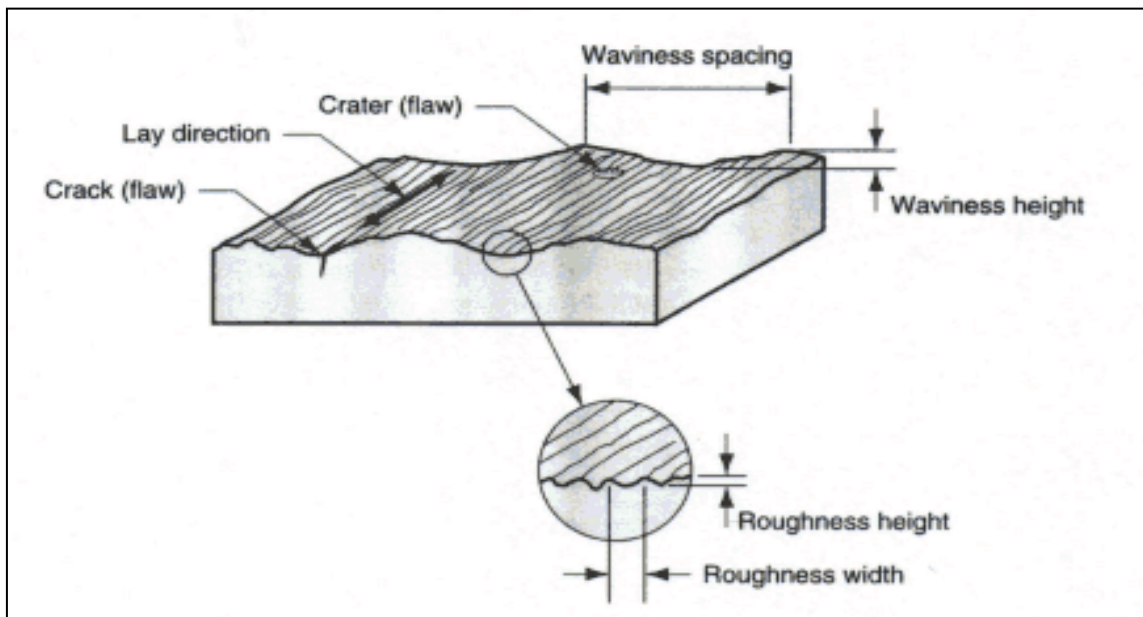

c) Factors that contribute to poor surface finish in cutting:

Factors, influencing surface roughness in machining are

- ❖ tool geometry (major cutting edge angle and tool corner radius),
- ❖ cutting conditions (cutting velocity and feed), and
- ❖ Work material properties (hardness).

d) Process parameters which improves surface finish:

The process parameters which improves surface finish are:

- ❖ Increasing the tool rake angle generally improves surface finish
- ❖ Higher work material hardness results in better surface finish
- ❖ Tool material has minor effect on surface finish.
- ❖ Cutting fluids affect the surface finish changing cutting temperature and as a result the built-up edge formation.

17. Explain the sources of heat generation in machining. (May 2016)

Sources of heat generation in machining:

- ❖ It is hard to predict the intensity and distribution of heat sources in individual machining operations. Because, the properties of material used in machining vary with temperature, the mechanical process and thermal dynamic process are tightly coupled together.

- ❖ In the elastic deformation, the energy required for the operation is stored in the material as strain energy and no heat is generated. However, in case of plastic deformation, most of the energy used is converted into heat.
- ❖ There are three sources/regions for heat generation in metal cutting,
 1. Primary deformation zone
 2. Tool-chip interface zone or Secondary deformation zone
 3. Tool work piece interface zone.

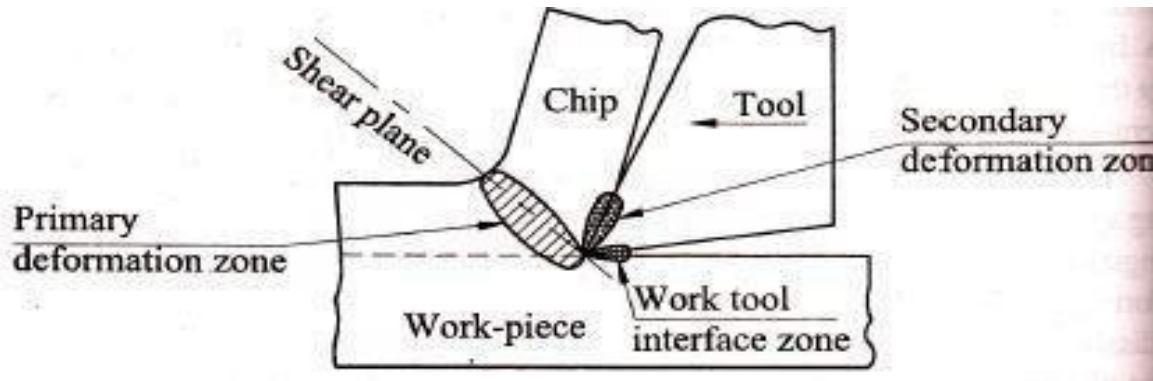
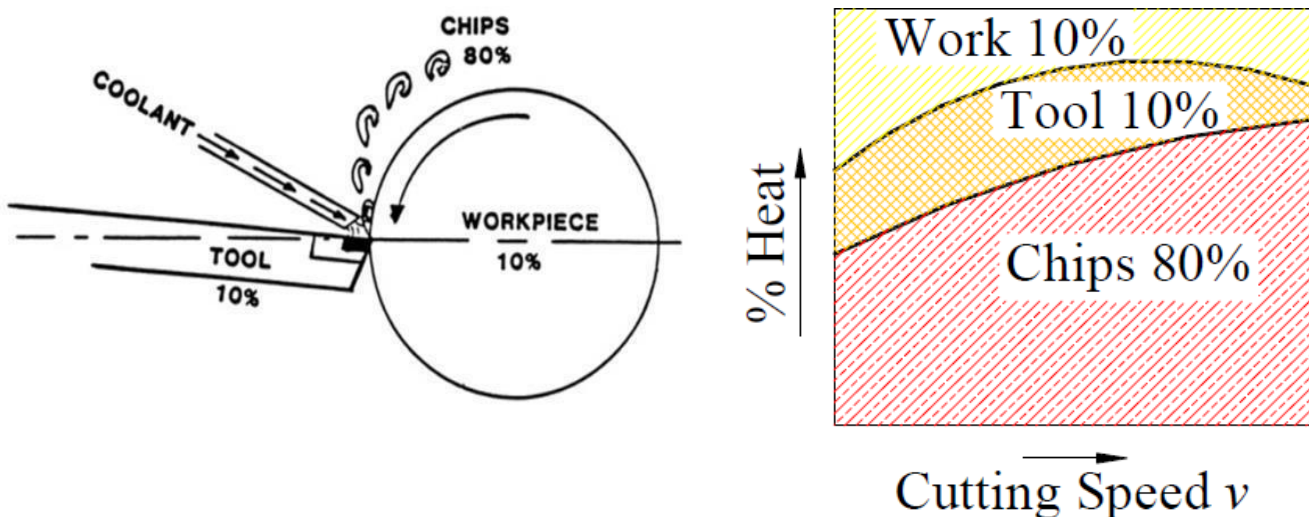

Fig: Source of heat generation in machining

- ❖ Heat generated in primary zone is mainly due to plastic deformation and viscous dissipation.
- ❖ In secondary zone, heat is generated due to chip distortion. Metal layer inside the bend and adjacent to tool tip is stretched while layer away from the tip is contracted. Hence, there is distortion of grains in the chip which leads to internal friction between heated chip and tool face.
- ❖ In Work-tool interface zone, heat is generated due to friction by rubbing action between portion of tool flank and work piece.

Heat Generated During Machining:

When the heat is obtained in one of three places Work piece, tool and chips too much, cutting edge will break down rapidly, reducing tool life.



Heat Dissipation

Heat Dissipation

- Ideally most heat taken off in chips
- Indicated by change in chip color as heat causes chips to oxidize
- Cutting fluids assist taking away heat
- Can dissipate at least 50% of heat created during machining

Heat is generated in the two deformation zones. Heat is also generated due to sliding of chip on the rake face. The heat generated results in increase of temperature of tool-chip interface and that of tool.

The size of primary zone of deformation depends upon the following factors:

- a) Rake angle of tool
- b) Cutting speed
- c) Properties of work material
- d) Friction on rake face

e) Rake angle

- ❖ The transition of work material into chip is gradual and the material suffers less severe deformation if rake angle of tool is large. The cutting forces are also small.
- ❖ If rake angle is small or negative, the material suffers more severe deformation. The cutting forces are also large.

f) Cutting speed

The thickness of primary zone of deformation reduces and zone becomes narrower with the increase of cutting speed

g) Work material

The size of the primary zone depends upon the following properties of work material.

- ❖ Strength
- ❖ Strain hardening
- ❖ Strain rate
- ❖ Heat conductivity

h) Friction on rake face

The size of both primary and secondary zones of deformation increases due to increase in friction between chip and tool rake face.

18. What are various factors which cause the cutting temperature to increase? (May 2006)

Effect of various factors on Cutting Temperature:

Material of tool and Work:

Higher hardness and tensile strength of material required more cutting force and hence higher heat generated.

a. Tool Geometry:

- ❖ Tool geometry basically refers to some specific angles pertinent to the cutting edges. Geometry of turning tool refers rake angles, clearance angles, auxiliary clearance angles, cutting angles and nose radius. All these angles basically express orientation of three tool point surfaces of a single point turning tool (SPTT).
- ❖ The rake angle has complex influence on the cutting temperature.
- ❖ If rake angle increase in positive direction both cutting force and amount of heat generated are decreased. Negative rake angle causes deformations.
- ❖ As the nose radius increase, volume of tool point is increases and it promotes more heat conduction.
- ❖ Large cross section area of tool shank leads more heat conduction and it reduces cutting temperature.

b. Cutting Parameter:

- ❖ As cutting speed increases, friction will increase. It raises the temperature of cutting zone.
- ❖ The cutting temperature is also increased with increase of feed and depth of cut.

c. Cutting Fluid:

- ❖ Cutting fluid reduces friction.
- ❖ It also absorbs and carry away heat from work, chips and tool.

19. Enumerate with neat sketch, measurement of cutting temperature using work-tool thermocouple method.(May/June 2016)

Describe with neat sketch the measurement of average chip tool interface temperature using tool-work thermocouple.(Nov/Dec 2016)

Tool work thermocouple technique:

- In a thermocouple two dissimilar but electrically conductive metals are connected at two junctions.
- Whenever one of the junctions is heated, the difference in temperature at the hot and cold junctions produce a emf which is proportional to change in temperature.
- Which is detected and measured by a milli-voltmeter
- In machining like turning, the tool and the job constitute the two dissimilar metals and the cutting zone functions as the hot junction.
- Then the average cutting temperature is evaluated from the mV after thorough calibration for establishing the exact relation between mV and the cutting temperature.
- The below figure typically shows a Tool-work thermocouple technique of measuring cutting temperature.

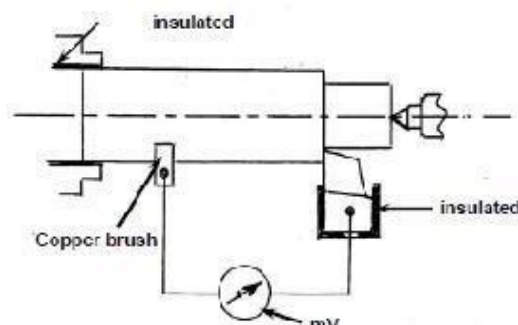

Fig. Tool-work thermocouple technique of measuring cutting temperature.

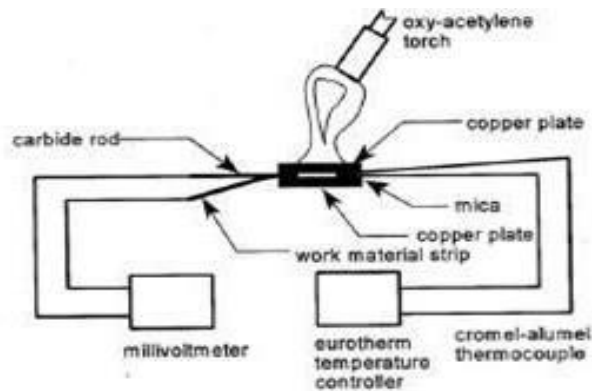

Fig:calibration for measuring average cutting temperature, θ_{avg} in turning steel rod by uncoated carbide tool.

TOOL WEAR:

20. Explain the following 1. Attrition and 2. Diffusion mechanisms of tool wear. (May'12)

1. Attrition:

- During cutting process the interface temperature, pressure is quite high and also high friction between tool-chip interface. It causes the chip material to weld itself to the tool face near the nose is called built-up edge.
- In low cutting speeds, the flow of metal from the cutting edge is irregular and less streamlined. Sometimes, the built-up edge might be formed but the contact will not be continuous. In this situation, the tool will start to tear from the tool surface. It is called as attrition.
- It occurs in continuous cutting but with interrupted cutting or due to lack of rigidity of the machine tool which will generate enormous vibrations and uneven work surfaces. All these reasons will lead the tool to destroy its cutting edges. Attrition could be minimized by increasing the cutting speed or using carbide tips as cutting edges where the built-up edge forms. Attrition wear shown in figure below.

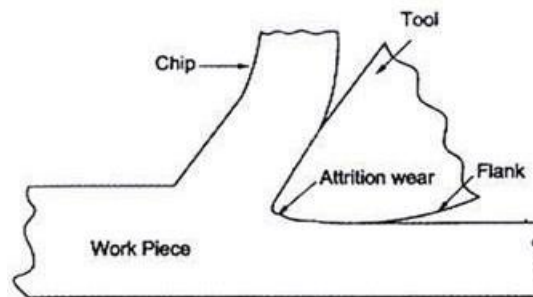

Figure 1.16 Attrition wear

2. Diffusion:

Diffusion wear happens due to the diffusion of metal and carbon atoms from the tool surface into the work material and chips. It is also due to high temperature and pressure existing at the contact

surfaces in metal cutting and rapid flow of chips. It mainly depends on the metallurgical properties of tool and work.

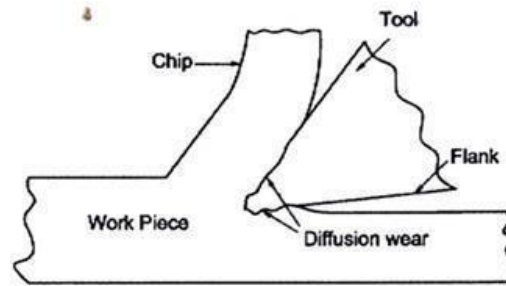

Figure 1.17 Diffusion wear

21. What are the various forms of wear found in cutting tools? Show with a neat sketch. (Nov.2006, Nov.2009, May 2010, May 2015)

Tool Wear:

The tool wear is generally classified as follows.

- (i) Flank wear (or) edge wear
- (ii) Face wear (or) Crater wear.
- (iii) Nose wear

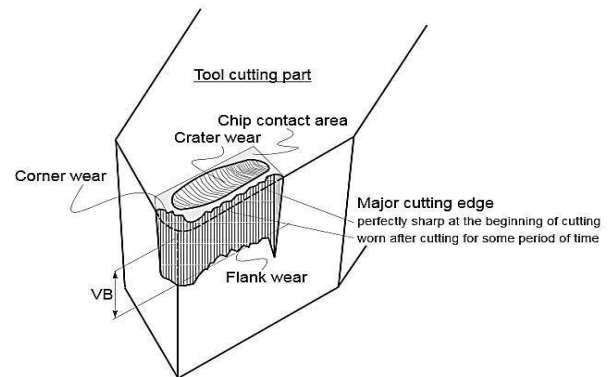
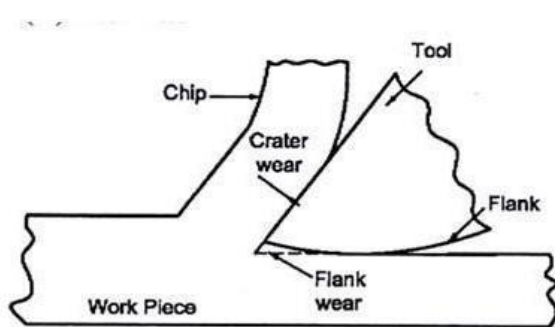

Figure 1.18 Tool wear

Types of wear observed in single point cutting tool

(i) Flank wear:

- This is also called "edge wear". Friction, abrasion, adhesions are the main causes for this type of wear. Flank wear is a flat worn out portion behind the cutting edge.
- The worn out region of the flank is known as wear land.
- This wear takes place when machining the brittle material such as cast iron. When the wear land increases, the frictional heat will cause excessive temperature of the tool at the cutting edge thereby decreasing its hardness rapidly and hence, the catastrophic failure of the tool will occur.
- Flank wear results a rough machined surface.

(i) Crater wear:

- The face of the tool is always contacted with the chip. The chip slides over the face of the tool. Due to the pressure of the sliding chip, the tool face gradually wears out.
- A cavity is formed on the tool face. The cavity is called crater. This type of wear is known as crater wear.

- The major tendency of this type of wear is due to abrasion between chip and face of the tool. When the cratering becomes excessive, the cutting edge may break from the tool. Cratering is commonly occurred while machining a ductile material which produces continuous chips.
- Diffusion of metal may be one of the causes of this type of wear. The maximum depth of the crater is usually a measure of the amount of the crater wear. The tool life due to crater wear can be determined by fixing the ratio of width of crater to its depth.

(ii) Nose wear:

- It is similar to flank wear in certain operations. The wear occurs on the nose radius of the tool. When the nose of the tool is rough, abrasion and friction between tool and work piece will be high.
- Due to this type of wear, more heat will be generated. Also more cutting force will act on the tool. This type of wear is more prominent than flank wear.

22. What is the measure of removing process machinability? (Nov 2005)

Machinability:

- ❖ The term machinability refers to the ease with which a metal can be machined to an acceptable surface finish.
- ❖ Materials with good machinability require little power to cut, can be cut quickly, easily obtain a good finish, and do not wear the tooling much are said to be free machining.
- ❖ Machinability can be difficult to predict because machining has so many variables. Two sets of factors are the condition of work materials and the physical properties of work materials.

I. Factors affecting the machinability:

- a. Chemical composition of work piece material.
- b. Microstructure of work piece material
- c. Mechanical properties like ductility, toughness etc.
- d. Physical properties of work materials.
- e. Method of production of the work materials.
- f. Tool geometry and tool material.
- g. Nature of engagement of tool with the work.

II. Method of evaluating machinability:

The following criteria suggested for evaluating machinability.

- a. Tool life per grind,
- b. Rate of removal per tool grind,
- c. Magnitude of cutting forces and power consumption. Surface finish.
- e. Dimensional stability of finished work.

III. Advantage of high machinability:

- a. Good surface finish can be produced,
- b. High cutting speed can be used,
- c. Less power consumption,
- d. Metal removal rate is high,
- e. Less tool wear.

IV. Machinability index:

It is a comparison of machinability of different material to standard material. As per US material standard for 100% machinability is SAE 1112 hot rolled steel.

Machinability index, I = $\frac{\text{Cutting speed of standard steel for 20 minutes tool life}}{\text{Cutting speed of metal investigated for 20 minutes tool life}}$

UNIT II TURNING MACHINES

Centre lathe, constructional features, specification, operations – taper turning methods, thread cutting methods, special attachments, machining time and power estimation. Capstan and turret lathes- tool layout – automatic lathes: semi-automatic – single spindle: Swiss type, automatic screw type – multi spindle:

SPECIFICATIONS:

What is lathe:

1. What is metal removal processes?

The metals removed from the workpiece to obtain the required shape and size by various processes.

2. Name the specifications of a centre lathe.(AU Dec 2013)

Lathe is specified by the following items:

1. The Height of the centres.
2. The Swing diameter over bed.
3. The length between centres.
4. The Swing diameter over carriage.
5. The maximum bar diameter.
6. The length of bed.

3. Write the specifications of a typical lathe. (April/May 2016)

1. The length of the bed
2. Maximum distance between live and dead centres.
3. The height of centres from the bed
4. The swing diameter
5. The bore diameter of the spindle
6. The width of the bed
7. The type of the bed
8. Pitch value of the lead screw
9. Horse power of the motor
10. Number and range of spindle speeds
11. Number of feeds
12. Spindle nose diameter
13. Floor space required
14. The type of the machine

4. List the types of lathes.

The types generally used are:

- 1) Engine lathe
 - a) Belt drive
 - b) Individual motor drive
 - c) Gear based lathe
- 2) Bench lathe.
- 3) Tool room lathe
- 4) Semi-automatic lathe.

- 5) Automatic lathe
- 6) Speed lathe
 - a) Wood working
 - b) Centering
 - c) Polishing
 - d) Spinning
- 7) Special purpose lathe

5. What are the principle parts of a lathe?

The principle parts of a lathe are:

- 1) Bed 2) Headstock 3) Tailstock 4) Carriage
- 5) Cross-slide 6) Tool post 7) Feed Mechanism 8) Thread cutting mechanism

6. What are the main requisites of a lathe bed?

- 1. The lathe bed should be very strong to withstand cutting forces and vibrations during machining.
- 2. It should be sufficiently rigid to prevent deflection under tremendous cutting pressure.
- 3. It must be massive with sufficient depth and width to absorb vibration.
- 4. It must be able to resist the twisting stress.
- 5. The bed should be seasoned naturally to avoid distortion or warp.

7. What are the uses of headstock?

Uses of headstock:

- 1 Headstock carries a hollow spindle with nose to hold the work piece.
- 2. It is used to mount the driving and speed changing mechanisms.
- 3. It provides mechanical means of rotating the work at multiple speeds.

8. What are the spindle mechanisms?

Spindle mechanism:

- 1. Step cone pulley drive
- 2. Back geared drive
- 3. All geared drive

9. What are the conditions to vary speed of the work piece to suit the different machining conditions?

The various conditions to vary speed of the work piece to suit the different machining conditions are:

- 1. The type of material to be cut
- 2. The type of cutting tool material used
- 3. The type of surface finish desired
- 4. The type of cutting fluid used
- 5. The rigidity and condition of the machine
- 6. The diameter of the work
- 7. The type of operation.

10. State the various parts mounted on the carriage. (AU may 2013)

The carriage of a lathe has several parts that serve to support, move and control the cutting tool. The various parts mounted on the carriage are:

- a. Saddle
- b. Compound rest
- c. Cross slide
- d. Tool post.

LATHE ACCESSORIES:

11. Write down the names of lathe accessories.

Lathe accessories include i) centres, ii) catch plates and carriers, iii) chucks, iv) collets, v) face plates, vi) angle plates, vii) mandrels, and viii) rests.

12. What is live centre?

A live center or revolving center is constructed so that the 60° center runs in its own bearings and is used at the non-driven or tailstock end of a machine. It allows higher turning speeds without the need for separate lubrication, and also greater clamping pressures.

13. What is dead centre?

A dead center (one that does not turn freely, i.e., *dead*) may be used to support the workpiece at either the fixed or rotating end of the machine. When used in the fixed position, a dead center produces friction between the workpiece and center, due to the rotation of the workpiece.

14. What is the main difference between live center and dead center?

The main difference between live center and dead center is:

- i. Live center drives and rotates along with the work pieces.
- ii. Dead center just supports which support the other end of the workpiece.

15. Name any four types of cutting tool used in a lathe.

Cutting tools: The tool used in a lathe is a single point tool, but for special operations multipoint tools may be used.

- 1. Forged tool
- 2. Brazed tipped tool
- 3. Solid tool
- 4. Mechanically fastened tipped tool.

16. How is a single point tool classified?

Classification of a single point tool:

1. According to the method of manufacturing the tool:

- a) Forged tool
- b) Tipped tool brazed to the carbon steel shank
- c) Tipped tool fastened mechanically to the carbon steel shank.

2. According to the method of holding the tool:

- a) Solid tool b) Tool bit inserted in the tool holder.

3. According to the method of using the tool:

- a) Turning b) Chamfering c) Thread cutting d) Facing
- e) Grooving f) Forming g) Boring h) Internal thread cutting
- i) Parting off

4. According to the method of applying feed:

- a) Right –hand b) Left-hand c) Round nose

17. State the various feed mechanisms used for obtaining automatic feed.

- 1) Tumbler gear mechanism
- 2) Quick change gearbox.
- 3) Tumbler gear-Quick change gearbox.
- 4) Apron mechanism.

18. Mention four different types of chucks used in a machine shop. (AU Dec 2009)

Chucks: A chuck is one of the most important devices for holding and rotating a piece of work in a lathe.

There are various types of chucks to suit various types of jobs. They are:

- 1) Four jaw Independent chuck.
- 2) Three jaw chuck (or) Self centering chuck
- 3) Air or hydraulic operated chuck
- 4) Magnetic chuck
- 5) Collet chuck
- 6) Combination chuck
- 7) Drill chuck

19. What is a four jaw independent chuck?

- ❖ Each jaw is moved independently by rotating a screw with the help of a chuck key. A particular jaw may be moved according to the shape of the work.
- ❖ Hence this type of chuck can hold works of irregular shapes.
- ❖ But it requires more time to set the work aligned with the lathe axis.
- ❖ Experienced turners can set the work about the axis quickly.
- ❖ Concentric circles are inscribed on the face of the chuck to enable quick centering of the workpiece.

20. What is three jaw chucks?

- The three jaws fitted in the three slots may be made to slide at the same time by an equal amount by rotating any one of three pinions by a chuck key.
- This type of chuck is suitable for holding and rotating regular shaped work pieces like round or hexagonal rods about the axis of the lathe.
- Work pieces of irregular shapes cannot be held by this chuck. The work is held quickly and easily as the three jaws move at the same time.

21. What is magnetic chuck?

- ❖ The holding power of this chuck is obtained by the magnetic flux obtained from the electromagnet placed inside the chuck.
- ❖ Magnets are adjusted inside the chuck to hold or release the work. Workpieces made of magnetic material only are held in this chuck.
- ❖ Very small, thin and light works which cannot be held in a ordinary chuck are held in this chuck.

22. What is Collet chuck?

Collet chuck has a cylindrical bushing known as collet. It is made of spring steel and has slots cut lengthwise on its circumference. So, it holds the work with more grips. Collet chucks are used in capstan lathes and automatic lathes for holding bar stock in production work.

23. What are the advantages of using a collect chuck? (AU Dec 2008)

- Collets offer higher levels of precision and accuracy than self-centering chucks.
- They have a shorter setting up time than independent-jaw chucks.
- The collet typically has a working range of 1 mm (about 0.04 in).
- Collets usually are made to hold cylindrical work, but are available to hold square, hexagonal or octagonal workpieces.
- Step collets are available that are machinable to allow holding of short workpieces that are larger than the capacity of normal collets

24. Mention the uses of chucks.

- i) For holding and rotating a piece of work in a lathe.
- ii) Work pieces of short length and large diameter or of irregular shape which cannot be conveniently mounted between centres are held quickly and rigidly in a chuck.

25. What is the application of air operated chuck?

- ❖ It's highly flexible design solves gripping or turning issues in turn-key applications.
- ❖ Compact and lightweight allowing for increased efficiency.
- ❖ Can be applied for mass produced metal working machines as ordinary attachments.
- ❖ Most helpful for clamping non-standard and complicated parts for finishing operation and fine finish cutting.

26. Why was power chucks developed? (AU Dec 2006) (Nov/Dec 2005)

Power chucks are primarily developed for the application as work holding devices for automatic machines, numerical control and CNC machine.

27. What is the purpose of a mandrel? How many types of mandrels is there in common use? (AU Dec 2009)

Purpose of a mandrel: Mandrel is used for holding hollow workpiece between centres. It rotates the workpiece that had been previously drilled or bored. It drives the work by friction.

Types of mandrels:

Different types of mandrels are employed according to specific requirements. They are

- 1) Plain mandrel
- 2) Step mandrel
- 3) Collar mandrel
- 4) Screwed mandrel
- 5) Cone mandrel
- 6) Gang mandrel
- 7) Expansion mandrel

28. Explain the following parts of lathe. (AU Dec 2010)

(a) Lathe bed (b) Carriage

Lathe bed:

- It is the base of the lathe. The head stock is mounted on the left end, the carriage in the middle and tailstock at the right end of the bed.
- The bed has flat or inverted "V" sideways. The carriage and the tailstock move along the guide ways over the bed. The bed material should have high compressive strength, should be wear resistant and absorb vibration.
- Cast iron alloyed with nickel and chromium material is suitable.

Carriage:

- It is supported on the lathe bed ways and can move in a direction parallel to the lathe axis. The carriage is used for giving various movements to the tool by hand and by power.
- It carries saddle, cross slide, compound rest, tool post and apron.

29. What is an apron? (AU Dec 2010)

Apron:

- ❖ The hanging part in front to the carriage is termed as the apron. It is attached to the saddle and hangs in front of the bed. It contains gears, clutches and levers for moving the carriage by a hand wheel or power feed.
- ❖ Apron is attached to the carriage and hangs over the front side of the lathe bed. It is useful in providing power and hand feed to both carriage and cross-slide.

Function of apron of a lathe:

- ⇒ The apron is fastened to the saddle, houses the gears and mechanisms required to move the carriage and cross-slide automatically.
- ⇒ The apron hand wheel can be turned manually to move the carriage along the Lathe bed. This hand wheel is connected to a gear that meshes in a rack fastened to the Lathe bed.
- ⇒ The automatic feed lever engages a clutch that provides the automatic feed to the carriage.

30. Why is hollow spindle used in Lathe? (AU dec2009)

- ⇒ The main spindle is generally hollow to allow long bars to extend through to the work area. This reduces preparation and waste of material.
- ⇒ The spindle runs in precision bearings and is fitted with some means of attaching workholding devices such as chucks or faceplates.
- ⇒ This end of the spindle usually also has an included taper, frequently a Morse taper, to allow the insertion of hollow tubular (Morse standard) tapers to reduce the size of the tapered hole, and permit use of centers

31. What are the functions of feed rod and lead screw? (AU Dec 2006)

Functions of feed rod:

- ❖ The feed rod is a long shaft that has a keyway.
- ❖ The power is transmitted from the lathe spindle to the apron gears through a feed rod via a large number of gears.
- ❖ The feed rod is used to move the carriage or cross slide for turning, facing and all other operations except thread cutting

Functions of lead screw:

- ❖ The lead screw is powered by gears from the head stock and is used for providing specific accurate mechanized movement to the carriage for cutting threads on the workpiece.
- ❖ The lead screw has a definite pitch. A split nut is used to engage the lead screw with the carriage.
- ❖ In some lathes, the lead screw performs the functions of feed rod and there is no separate feed rod.

32. Why is it essential that the cutting point of the tool should be level with the spindle center while machining taper on a work piece? (AU Dec 2008)

A taper may be turned in a lathe by feeding the tool at an angle to the axis of rotation of the workpiece. The angle formed by the path of the tool with the axis of the workpiece should correspond to

the half taper angle. So, while turning taper, it is essential that the tool cutting edge should be set accurately on the centre line of the work piece otherwise correct taper will not be obtained.

33. What is the purpose of tumbler gear mechanism of a lathe?(AUB MAY 2012)

Purpose of Tumbler gear mechanism:

The purpose of moving the carriage towards or away from the headstock, this mechanism along with feed rod or leadscrew is used. Tumbler gears are two small pinions mounted on a bracket. This bracket is pivoted about the axis of the stud gear.

The different speed of driving shaft is obtained by a tumbler gear. A tumbler gear and a sliding gear are attached to the bracket. Driving shaft has a cone gear made up of different sizes of gears. The sliding gear is keyed to the driven shaft which is connected by the lead screw or feed rod. The sliding gear can be made to slide and engaged at any desired position. By sliding the sliding gear to various positions and engaging the tumbler gear, various speeds can be obtained.

LATHE OPERATIONS:

34. What are the various operations that can be performed on a lathe?

- | | | | |
|---------------|-------------------|--------------|-----------------|
| 1) Turning | 2) Facing | 3) Forming | 4) Knurling |
| 5) Chamfering | 6) Thread cutting | 7) Drilling | 8) Boring |
| 9) Recessing | 10) Tapping | 11) Grooving | 12) Cutting off |

35. Define filing operation.

Filing operation:

Filing is the finishing operation performed after turning. It is the process of removing bars, sharp corners and feed marks on a workpiece by removing very small amount of metal. The file should be slowly moved forwards so that the work may pass 2 to 3 revolution during the cutting stroke.

36. Draw the different types of Lathe operations.

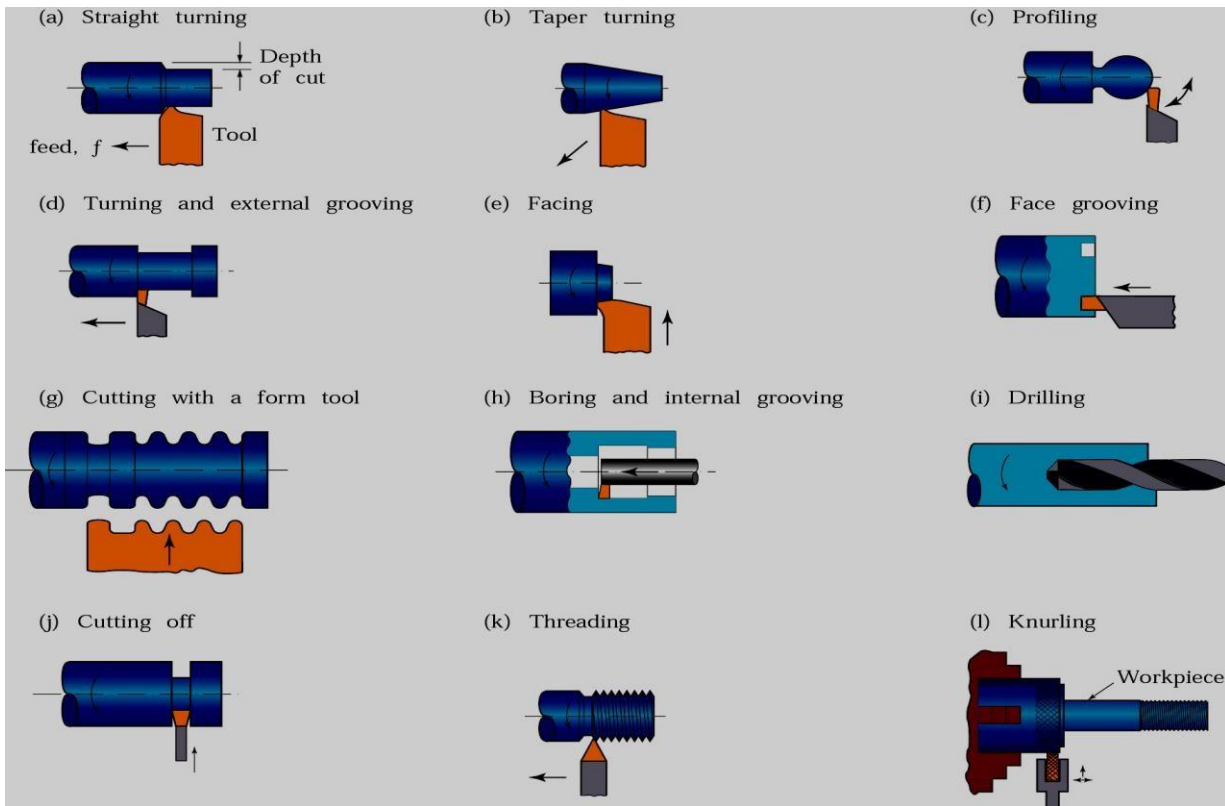

37. Define the process "grooving".

Grooving: Grooving is the process of reducing the diameter of the work piece over a very narrow surface. It is often done at the end of a thread or adjacent to a shoulder to leave a small margin. The work is revolved at half the speed of turning and a grooving tool of required shape is fed straight into the work by rotating the crossslide screw. A grooving tool is similar to a parting – off tool.

38. What is meant by parting off?

Parting off:

Parting off is an operation of Lathe. It is cutting a work piece after machining.

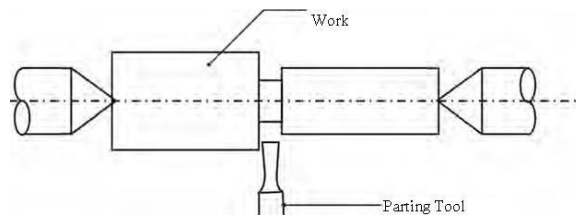

39. What is reaming and boring operation?

Reaming: - The operation of finishing and sizing an already drilled hole.

Boring: - The process of enlarging a already drilled hole.

TAPER TURNING:

40. List methods by which taper turning is done in a centre lathe. (AU may 2011)

(AU Apr 2010& Dec2009)

Taper:

A taper may be defined as a uniform increase or decrease in diameter of a piece of work measured along its length.

Taper turning methods:

A taper can be turned by any one of the methods. They are

1. Form tool method
2. Compound rest method
3. Tailstock set over method
4. Taper turning attachment method
5. Combined feed method

41. Write down the formula for calculating taper turning angle by compound rest method.

Formula for calculating taper turning angle by compound rest method:

$$\tan \alpha = \frac{D-d}{2 l}$$

Where,

D - Bigger diameter

d - Smaller diameter

l - Length of the work piece

42. Define the term ‘Conicity’.

Conicity: It is the ratio of the difference in diameters of the taper to its length.

$$k = \frac{D-d}{L}$$

Where,

D - Bigger diameter

d - Smaller diameter

L- Length of the work piece

43. Determine the angle at which the compound rest will be swiveled when cutting a taper on a piece of work having the following dimensions.

- a) Outside Diameter – 60mm
- b) Length of The Tapered Portion 80mm And
- c) Smallest Diameter = 20mm

Given Data:

$$D = 60\text{mm}$$

$$L = 80\text{mm (Length of Tapered Portion)}$$

$$d = 20\text{mm}$$

Solution:

$$\tan \theta = \frac{D-d}{2 l}$$

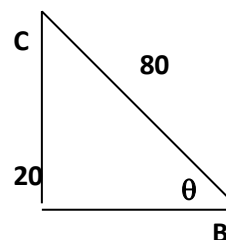

$$= \frac{60-20}{2 \times 80}$$

$$\theta = 20^{\circ}15''$$

44. Write notes on Form tool method of taper turning.

Form tool method:

- ❖ A broad nose tool is ground to the required length and angle. It is set on the work by providing feed to the cross-slide.
- ❖ When the tool is fed into the work at right angles to the lathe axis, a tapered surface is generated. This method is limited to turn short lengths of taper only.
- ❖ The length of the taper is shorter than the length of the cutting edge. Less feed is given as the entire cutting edge will be in contact with the work.

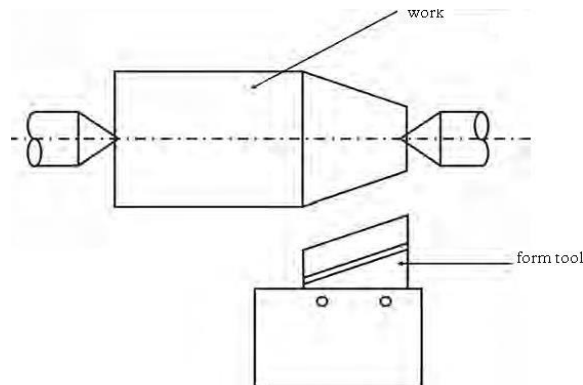

45. What is taper turning by compound rest method?

Compound rest method:

Taper turning by compound rest method

The compound rest is swiveled to the angle calculated as above and clamped. Feed is given to the compound slide to generate the required taper.

The compound rest of the lathe is attached to a circular base graduated in degrees, which may be swiveled and clamped at any desired angle. The angle of taper is calculated using the formula

$$\tan \phi = \frac{60-20}{2 \times 80}$$

Where D – Larger diameter
 d – Smaller diameter
 l – Length of the taper
 Ø - Half taper angle

THREAD CUTTING:

46. Define the term 'Thread cutting'.

Thread cutting:

Thread cutting is one of the most important operations performed in a lathe. The process of thread cutting is to produce a helical groove on a cylindrical surface by feeding the tool longitudinally when

the job is revolved between centres or by a chuck. The longitudinal feed should be equal to the pitch of the thread to be cut per revolution of the work piece.

47. What is a centre gauge that is used in threading? (AU May 2014)

- A center gauge, also sometimes known as a fishtail gauge, is a tool used in machining to check the angle of tool bits used to cut screw threads.
- It is a small, flat handheld object made of metal, about 2 1/4 inches by 3/4 inch (approximately 57 by 19 millimeters) in size.
- Triangular notches are cut into the metal at precise dimensions and angles, and these notches are used as templates for shaping the machine tool bit.
- For the finished screw to function correctly, the threads of the screw must be cut at a precise and uniform angle. The center gauge helps ensure that the tool bit is the correct dimensions to cut these threads.

48. What are the various thread cutting methods? (AU Apr 2011)

Thread cutting methods:

- ❖ Taps and dies
- ❖ Single-point threading

Tap and die and Die head

- ❖ Common method of threading is cutting with taps and dies. In manual thread cutting, normal wrench usage is to cut the threads 1/2 to 2/3 of a turn (180 to 240 degree rotation), then reverse the tap for about 1/6 of a turn (60 degrees) until the chips are broken by the back edges of the cutters.
- ❖ It may be necessary to periodically remove the tap from the hole to clear the chips, especially when a blind hole is threaded.
- ❖ For continuous tapping operations (i.e., power tapping) specialized spiral point or "gun" taps are used to eject the chips and prevent crowding.

Single-point threading:

- ❖ Single-point threading is an operation that uses a single-point tool to produce a thread form on a cylinder or cone.

49. How is thread chased in a lathe?(AU may 2010)

Thread chaser: A chaser is a multipoint threading tool having the same form and pitch of the thread to be chased. A chaser is used to finish a partly cut threads to the size and shape required. Thread chasing is done at 1/3 to 1/2 of the speed of turning.

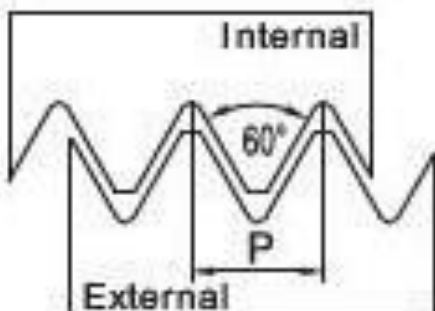

MACHINING TIME AND POWER ESTIMATION:

50. Give the expression to estimate the power required in machining.

Estimation of power required:

$$\text{Power} = \frac{2 \times \pi \times N \times F \times d}{60} \text{ Nm/s}$$

Where N = Speed in r.p.m

F = Force in Kg

D = Diameter of the rod in meters.

51. Give the expression for cutting speed.

Cutting speed:

The cutting speed is the distance travelled by a point on the outer surface of the work in one minute. It is expressed in meters per minute.

$$\text{Cutting speed} = \frac{\pi \times n \times d}{1000} \text{ m/min.}$$

Where, „d“ - is the diameter of the work in mm.

„n“ - is the r.p.m. of the work.

52. A shaft of 25 mm diameter is turned at a cutting speed of 50 m/min. Find the rpm of the shaft.

$$\text{Cutting speed} = \frac{\pi \times n \times d}{1000} \text{ m/min.}$$

$$\text{(Or)} \quad 50 = \frac{\pi \times n \times 25}{1000}$$

$$n = \frac{50 \times 1000}{\pi \times 25} = 637 \text{ rpm.}$$

53.a.) Calculate the power required for a steel rod of diameter 30mm at 200 rpm. Assume cutting force of 160 kg.(AU Dec 2007)

Diameter, „d“ = 30mm = 30/1000 = 0.030m

Speed „N“ = 200 rpm

Force „F“ = 160 Kg = 160/9.81 = 16.309 Nm

$$\text{Power} = \frac{2 \pi N F \times d}{60} = \frac{2 \times \pi \times 200 \times 16.309 \times 0.03}{60 \times 2} = 5.12 \text{ Nm/sec}$$

b.) Find the gears for cutting screw of lead 1/28 inch on a lathe whose leadscrew has a 4 threads per inch.

Lead screw has 4 t.p.i so pitch = 1/4 inch

$$\frac{\text{Driver teeth}}{\text{Driven teeth}} = \frac{\text{Pitch of the work}}{\text{Pitch of the leadscrew}}$$

$$= \frac{1}{\frac{1}{28}} = \frac{4}{28} = \frac{2 \times 2}{4 \times 7} = \frac{2 \times 20}{4 \times 20} \times \frac{2 \times 10}{7 \times 10}$$

$$= \frac{40 \times 20}{80 \times 70}$$

The driving gears will have 40 & 20 T, and the driven gears 80 & 70 T.

54. Define depth of cut and give the expression for it.

Depth of cut:

The depth of cut is the perpendicular distance measured from the machined surface to the uncut surface of the work piece. It is expressed in millimeters.

In a lathe, the depth of cut is expressed as follows

$$\text{Depth of cut} = \frac{d_1 - d_2}{2}$$

Where „d1“ - diameter of the work surface before machining

„d2“ - diameter of the machined surface

CAPSTAN AND TURRET LATHE:

55. Distinguish between Capstan or Ram type lathe and Turret or saddle type lathe. (AU Apr 2010)

Turret or saddle type lathe	Capstan or Ram lathe
1. Turret tool head is directly fitted on the saddle and both of them appear like one	1. Turret head is mounted on a slide called ram which is mounted on the
2. Saddle is moved to provide feed to the tool	2. To provide feed to the tool, saddle is locked at a particular point and the ram
4. As the saddle can be moved along the entire length of the bed, it is suitable for	4. As the movement of the ram is limited, it is suitable for machining
5. To index the turret tool head, a clamping lever is released and the turret	5. When the hand wheel for the ram is reversed, the turret tool head is indexed
6. Limit dogs are used to control the distance of tool movement.	6. To control the distance of tool movement, feed stop screws are provided at
7. Some turret lathes have the facility of moving the turret at right angles to the lathe axis	7. No such facility
8. Heavy and sturdy	8. Lighter in construction.
9. Suitable for machining heavy and large work pieces.	9. Only small and light work pieces are Machined.
10. Machining can be done by providing more depth of cut and feed.	10. Only limited amount of feed and depth of cut are provided for machining.

56. Name any four tool holding devices.

Tool holding devices:

- 1) Multiple cutter holders.
- 2) Offset cutter holder.
- 3) Sliding cutter holder.
- 4) Knee tool holder.

57. What is an offset cutter holder and give its applications?

Offset cutter holder:

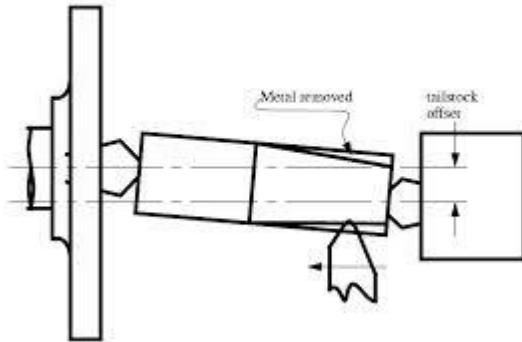

- ❖ The holder body is made offset with the shank axis.
- ❖ Larger length of work may be turned into taper surface or bored by this type of holder.

58. What type of mechanism is used for indexing the turret head for the next operation?

Geneva or Indexing mechanism.

The Geneva drive or Maltese cross is a mechanism that translates a continuous rotation into an intermittent rotary motion. It is an intermittent gear where the drive wheel has a pin that reaches into a slot of the driven wheel and thereby advances it by one step. The drive wheel also has a raised circular blocking disc that locks the driven wheel in position between steps.

59. Draw a neat sketch of 'Geneva mechanism' used in turret lathes for automatic indexing. (AU may 2011)

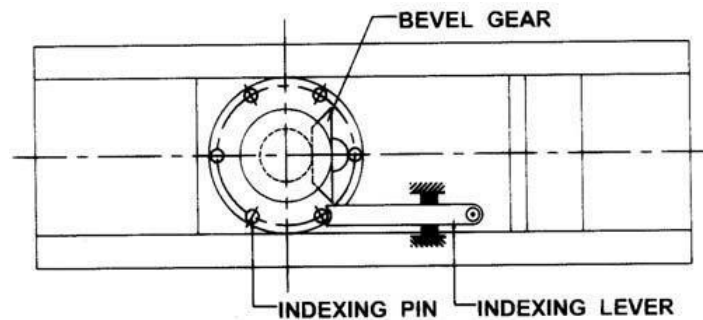

60. How is the size of a turret lathe specified? (AU dec2009)

- The size of a capstan or turret lathe is designated by the maximum diameter of rod that can be passed through the headstock spindle and the swing diameter of the work that can be rotated over the lathe bed ways.
- In order to specify the lathe fully other important particulars such as number of spindle speeds, number of feeds available to the carriage and turret saddle, net weight of the machine, floor space and power required, etc., should also be stated.

61. Write the formula for the following:

- 1) Machining time
- 2) Total Tool travel
- 3) Number of passes

$$1. \text{ Machining time} = \frac{L}{f \times N}$$

$$2. \text{ Total length of tool travel} = l + x + y$$

$$3. \text{ Number of passes or cuts} = \frac{\text{Total machining allowance}}{\text{Material removal per cut}}$$

Where, L = Total length of work piece,

x = length of tool approach

f = Feed ,

N = speed and

y = Over run,

SEMI-AUTOMATIC LATHE:

62. What is a semi-automatic lathe?

A lathe in which all the machining operations are performed automatically and loading and unloading of work piece, coolant on or off is performed manually. Turret and Capstan lathes are known as semi-automatic lathes.

The two types are:

- 1) Capstan lathe
- 2) Turret lathe

63. What are the advantages semi-automatic lathes?

Advantages of semi-automatic lathes:

- 1) Production time is minimized.
- 2) Accuracy will be high.
- 3) Production rate is increased.

AUTOMATIC LATHES:

64. Define automatic machine.

- Machines capable of handling the work piece as well as performing the metal cutting operations automatically are known as automatic machines.
- In addition to automatic machining operations loading and unloading are also performed automatically.

65. What is the need of automatic lathes? (AU Dec 2013)

Need of automatic lathes:

- ❖ For higher and faster rate of productivity
- ❖ Greater accuracy
- ❖ Lesser time for production per component
- ❖ For multi job machining
- ❖ Lesser manual operations
- ❖ Less likelihood of human error.
- ❖ Better production control
- ❖ Increase in manufacturing efficiency.
- ❖ Lower work force

66. Write the classification of Automats.

1. Classification According to the Type Of Work Material Used
 - ❖ Bar Stock Machine
 - ❖ Chucking Machine
2. Classification According to the Number Of Spindles
 - ❖ Single Spindle Automats
 - ❖ Multi Spindle Automats
3. Classification According to the Arrangements Of Spindles
 - ❖ Horizontal Spindle Type
 - ❖ Vertical Spindle Type
4. Classification According to the Feed Control
 - ❖ Single Cam Shaft Rotating At Constant Speed
 - ❖ Single Cam Shaft With Two Speeds
 - ❖ Two Cam Shaft
5. Classification According to the Use
 - ❖ Single Purpose Machine
 - ❖ General Purpose Machine

67. Define feed.

- Feed is defined as the movement of the tool relative to the work piece. The lathe tool can be given three types of feed namely, *Longitudinal, Cross and Angular*.
- When the tool moves parallel to the axis of the lathe, the movement is called longitudinal feed. This is achieved by moving the carriage.
- When the tool moves perpendicular to the axis of the lathe, the movement is called cross feed, this is achieved by moving the cross slide.
- When the tool moves by an angle to the axis of the lathe, the movement is called angular feed. This is achieved by moving the compound slide, after swiveling it at an angle to the lathe axis.

68. What are programmed automatic lathes? (may 2014)

Conventional/programmable lathe

- Basically conventional m/c has 2 axis known as X & Y axis. There is also a Z axis along which only the bed moves vertically. The spindle along with the tool does not move as it is fixed with the m/c body.

Computerized numerically controlled lathes

- ❖ Cutting-tool movements controlled by computer-controlled program to perform sequence of operations automatically.

69. What are the types of single spindle automatic lathes?(AU may2013)

Types of single spindle automatic lathes:

Single spindle machine are machines which can machine one component at a time as they have only one spindle. The different types are:

- ❖ Automatic cutting off machines
- ❖ Swiss type machine
- ❖ Automatic screw cutting machine

70. State the purpose of providing a lead cam in single spindle automatic screw cutting

Machine and also explain Copy turning. (AU DEC2012)

Purpose of providing a lead cam in single spindle automatic screw cutting machine:

The turret head in an automatic screw cutting machine rotates about a horizontal axis. The turret slide travel is controlled by a lead cam. The lead cam gives a slow forward and fast return movement to the turret slide.

A machine used for the reproduction of plane and curved surfaces from a master (template, pattern, model, or blueprint) on products made of various materials.

COPY TURNING:

Copying lathes are made for plane, contour, three-dimensional, and combined profiling with a mechanical, hydraulic, electric, or photoelectric servo mechanism or without a servo mechanism.

71. What is Swiss type automat? (AU Apr 2011)

This machine was designed and developed In Switzerland. So it is often called as Swiss Auto Lathe. The machine is also known as Sliding Head Screw Machine (or) Movable Head Stock Machine. This machine is used for machining long accurate parts of small diameters (2 to 25mm). These parts are produced from bar stock.

72. List the advantages of Swiss Type Screw Cutting Machine.

1. Wide Range Of Speeds
2. Rigid Construction
3. Micrometer Tool Setting
4. Interchangeability Of Cams
5. Simple Design Of Cams
6. Tolerance Of 0.005 To 0.0125mm Are Obtained
7. Numerous Working Stations

73. What are the advantages of automatic lathes? (AU Dec 2006)

1. Mass Production of Identical Parts.
2. High Accuracy is Maintained
3. Time of Production is Minimized
4. The Bar Stock is Fed Automatically.

**74. What are the limitations of centre lathe when compared to automatic Lathes? (AU may 2012)
(April/May 2016)**

- ❖ There is only one tool post
- ❖ Only one cutting tool can be held in the tailstock
- ❖ No provision to control the tool movement (feed) automatically
- ❖ Only one tool can be put into machining at a time.
- ❖ Tools have to be set every time according to the operation to be performed
- ❖ Setting of tools will take more time
- ❖ A skilled operator is necessary to work on the machine
- ❖ The machine has to be stopped to change the tool
- ❖ The production cost is high

75. How are multi spindle Automats classified?

Multi-Spindle Automatic Lathes Are Classified As Follows:

1. According to the type of Work Piece (Stock) Used
 - ❖ Bar type Machine
 - ❖ Chucking type Machine
2. According to the Arrangement of Spindle
 - ❖ Bar type Machine
 - ❖ Chucking type Machine
3. According to the Principle of Operation
 - ❖ Parallel Action type
 - ❖ Progressive Action type

76. Distinguish between parallel action and Progressive action machine.

Sl.No	Parallel Action Machine	Progressive Action Machine
1	Same operation is done on all jobs in all the spindles	Different operation are done on jobs at each station one after another
2	In one cycle, the number of components produced simultaneously is equal to the number of spindles	It is not so, (i.e) the number of components produced in one cycle is not equal to the number of spindles. for every indexing of component (spindle) one component is produced
3	Rate of production is very high	Rate of production is moderate
4	If anything goes wrong in one station, the production in that particular station only is affected	If anything goes wrong in one station, the production is completely affected in all the stations.

76. Discuss any two operations that can be performed in a lathe. (April/May 2015)

The machining operations generally carried out in centre lathe are:

- **Facing** - Machining the end of the work piece to produce flat surface.
- **Centering** - The operation of producing conical holes on both ends of the work piece.
- **Chamfering** - The operation of beveling or turning a slope at the end of the work piece.
- **Shouldering** - The operation of turning the shoulders of the stepped diameter work piece.
- **Grooving** - The operation of reducing the diameter of the work piece over a narrow surface. It is also called as recessing, undercutting or necking.
- **Knurling** - The operation of producing a diamond shaped pattern or impression on the surface.
- **Turning** – Turning is a form of machining, a material removal process, which is used to create rotational parts by cutting away unwanted material.

TURNING MACHINES

16 MARK QUESTIONS AND ANSWERS

1. Explain the construction of lathe and its working. (Dec 2006)

What are the various methods available for supporting long components and fragile components in a lathe? Explain with neat sketches. (April/ May 2015)

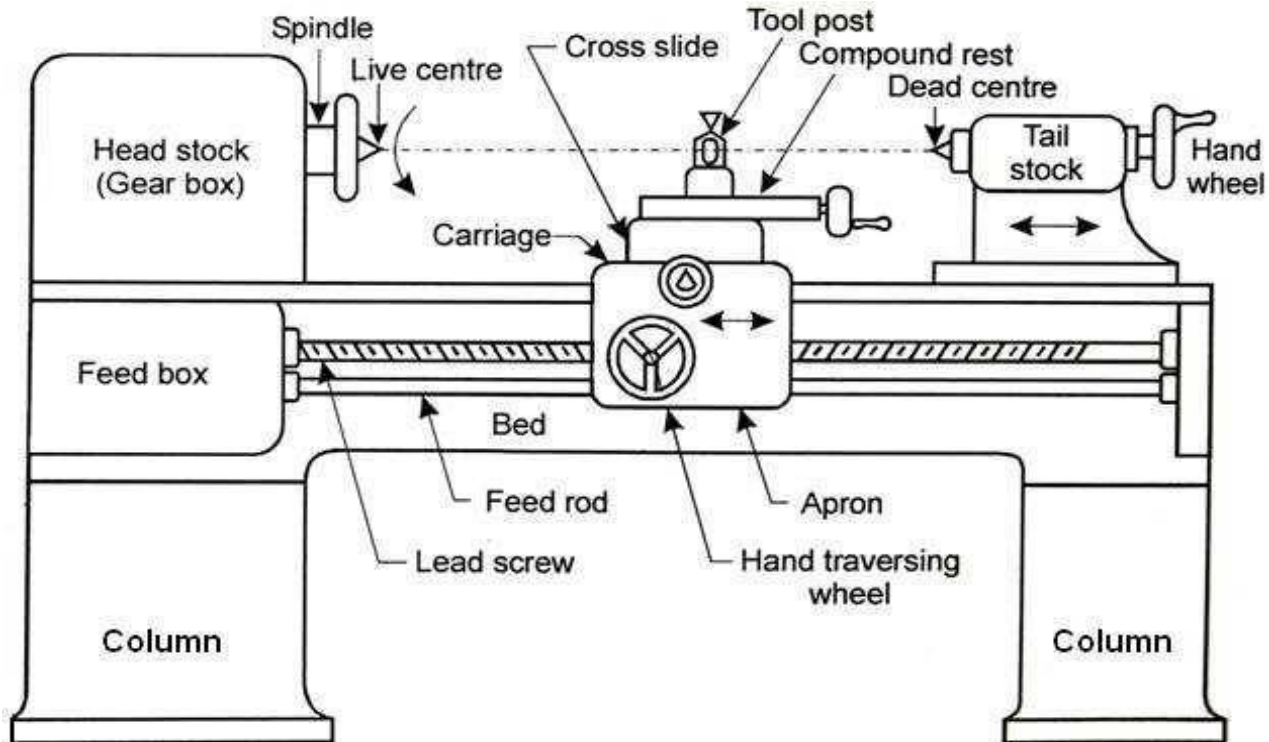

Schematic view of a centre lathe

CONSTRUCTION

Bed and Ways

- The bed is the base or foundation of the parts of the lathe.
- The main feature of the bed is the ways, which are formed on the bed's upper surface and run the full length of the bed.
- The ways keep the tailstock and the carriage, which slide on them, in alignment with the headstock.

Headstock

- The headstock assembly is permanently fastened to the left end of the bed. It carries a hollow spindle so that bars can be passed through it, when it's required.
- The spindle nose of the spindle is threaded to hold the chuck or face plate. The spindle is rotated by a combination of gears and cone pulleys or by gears alone.
- A live centre can be attached into the spindle. The headstock has the driving and speed changing mechanisms. The headstock may be of back-gear type or all geared type.
- There are speed changing and feed changing levers attached to the headstock.

Tailstock

- Tailstock is situated at the right end of the bed. It is used for supporting the right end of work. It consists of a taper hole adjusting screw and hand wheel.
- It can be moved along the bed and clamped to the bed at the desired location. Tailstock is also used to hold a drill, reamer or tap for drilling, reaming or tapping operations.

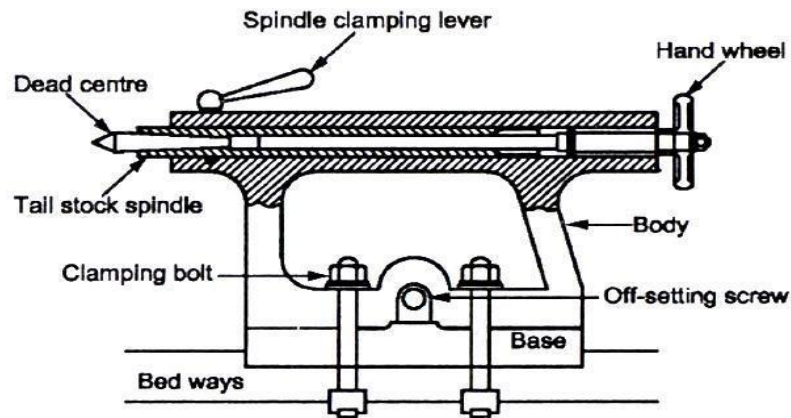

Carriage

- The carriage is the movable support for the cross feed slide and the compound rest.
- The compound rest carries the cutting tool in the tool post. This shows how the carriage travels along the bed over which it slides on the outboard ways.
- The carriage has T-slots or tapped holes to use for clamping work for boring or milling.
- You can lock the carriage in any position on the bed by tightening the carriage clamp screw.
- But you do this only when you do such work as facing or parting-off, for which longitudinal feed is not required.

Apron

- The apron is fitted to the saddle and hung in the front side of bed.
- It has several gears, levers and clutches for moving the carriage with the lead screw for thread cutting. It has a split nut for automatic thread cutting operation.
- The detailed mechanism is explained in further sections.

Feed Rod

- The feed rod transmits power to the apron to drive the longitudinal feed and cross feed mechanisms.
- The rotating feed rod drives gears in the apron; these gears in turn drive the longitudinal feed and cross feed mechanisms through friction clutches.
- Some lathes do not have a separate feed rod, but use a spline in the lead screw for the same purpose.

Lead Screw

- The lead screw is used for thread cutting. It has accurately cut Acme threads along its length that engage the threads of half-nuts in the apron when the half-nuts are clamped over it.
- The lead screw is driven by the spindle through a gear train. Therefore, the rotation of the lead screw bears a direct relation to the rotation of the spindle.
- When the half-nuts are engaged, the longitudinal movement of the carriage is controlled directly by the spindle rotation.

Cross feed Slide

- The cross feed slide is mounted to the top of the carriage in a dovetail and moves on the carriage at a right angle to the axis of the lathe.
- A cross feed screw allows the slide to be moved toward or away from the work in accurate increments.

Compound Rest

- Compound rest is mounted on the top of the cross slide. It is used for supporting the tool post and cutting tool in various positions.

- The base of the compound rest is marked in degrees. The tool post can be swiveled to various angular positions for different turning operations.

Saddle

It carries the cross slide, compound rest and tool post. It is an H-shaped casting fitted over the bed. It moves along to guide ways.

Accessories and Attachments

- Accessories are the tools and equipment used in routine lathe machining operations. Attachments are special fixtures that may be mounted on the lathe to expand the use of the lathe to include taper cutting, milling, and grinding.
- Some of the common accessories and attachments are described in the following paragraphs.

Tool Post:

- The sole purpose of the tool post is to provide a rigid support for the tool. It is mounted in the T-slot of the compound rest.
- A forged tool or a tool holder is inserted in the slot in the tool post. By tightening a setscrew, you will firmly clamp the whole unit in place with the tool in the desired position.

Tool holders:

- Notice the angles at which the tool bits are set in the various holders. These angles must be considered with respect to the angles ground on the tools and the angle that the tool holder is set with respect to the axis of the work.
- Two types of tool holders that differ slightly from the common tool holders are those used for threading and knurling.

The threading tool holder has a formed cutter which needs to be ground only on the top surface for sharpening.

A knurling tool holder carries two knurled rollers which impress their patterns on the work as it revolves.

Feed mechanism

- The movement of the tool relative to the work piece is termed as “feed”. The lathe tool can be given three types of feed, namely, longitudinal, cross and angular.
- When the tool moves parallel to the axis of the lathe, the movement is called longitudinal feed.
- This is achieved by moving the carriage.
- When the tool moves perpendicular to the axis of the lathe, the movement is called cross feed.
- This is achieved by moving the cross slide.

2. Explain kinematic system and working principle of a centre lathe. (April/May 2006)

KINEMATIC SYSTEM AND WORKING PRINCIPLE OF A CENTRE LATHE

For machining in machine tools the job and the cutting tool need to be moved relative to each other. *The tool-work motions are:*

- Formative motions: - cutting motion, feed motion.
- Auxiliary motions: - indexing motion, relieving motion.
- Cutting motion is attained by rotating the job and feed motion is attained by linear travel of the tool either axially for longitudinal feed or radially for cross feed.
- The job gets rotation (and power) from the motor through the belt pulley, clutch and then the speed gear box which splits the input speed into a number (here 12) of speeds by operating the cluster gears.

- The cutting tool derives its automatic feed motion(s) from the rotation of the spindle via the gear quadrant, feed gear box and then the apron mechanism where the rotation of the feed rod is transmitted.

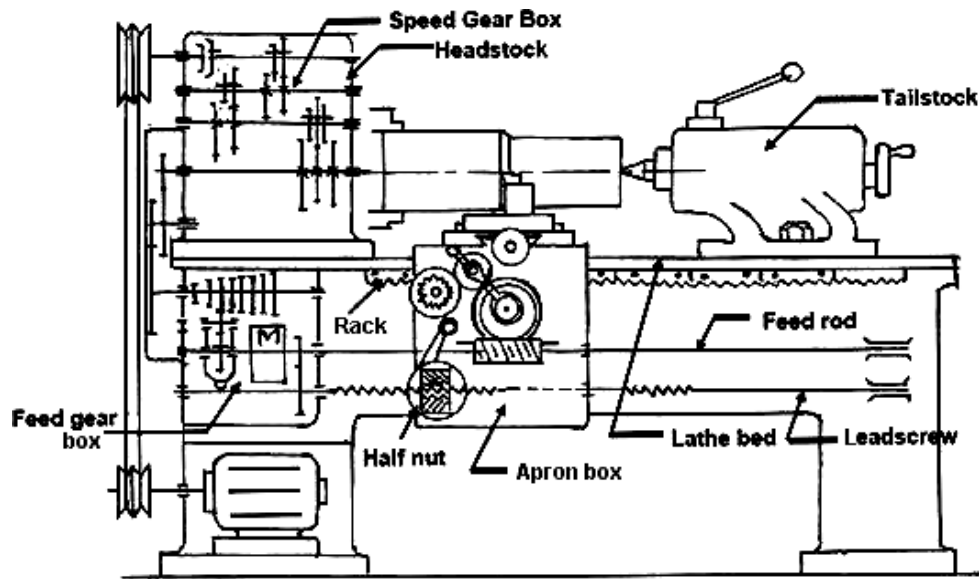

Fig. schematically shows the kinematic system of a 12 speed centre lathe.

- Either to the pinion which being rolled along the rack provides the longitudinal feed Or to the screw of the cross slide for cross or transverse feed.
- While cutting screw threads the half nuts are engaged with the rotating lead screw to positively cause travel of the carriage and hence the tool parallel to the lathe bed i.e., job axis.
- The feed-rate for both turning and threading is varied as needed by operating the Norton gear and the Meander drive systems existing in the feed gear box (FGB).
- The range of feeds can be augmented by changing the gear ratio in the gear quadrant connecting the FGB with the spindle.
- As and when required, the tailstock is shifted along the lathe bed by operating the clamping bolt and the tailstock quill is moved forward or backward or is kept locked in the desired location.
- The versatility or working range of the centre lathes is augmented by using several special attachments.

3. Explain headstock driving mechanisms and its types.

There are two types of headstock driving mechanisms as follows:

- a. Back geared headstock.
- b. All geared headstock.

a. Back geared headstock:

The back geared Headstock is shown in figure below:

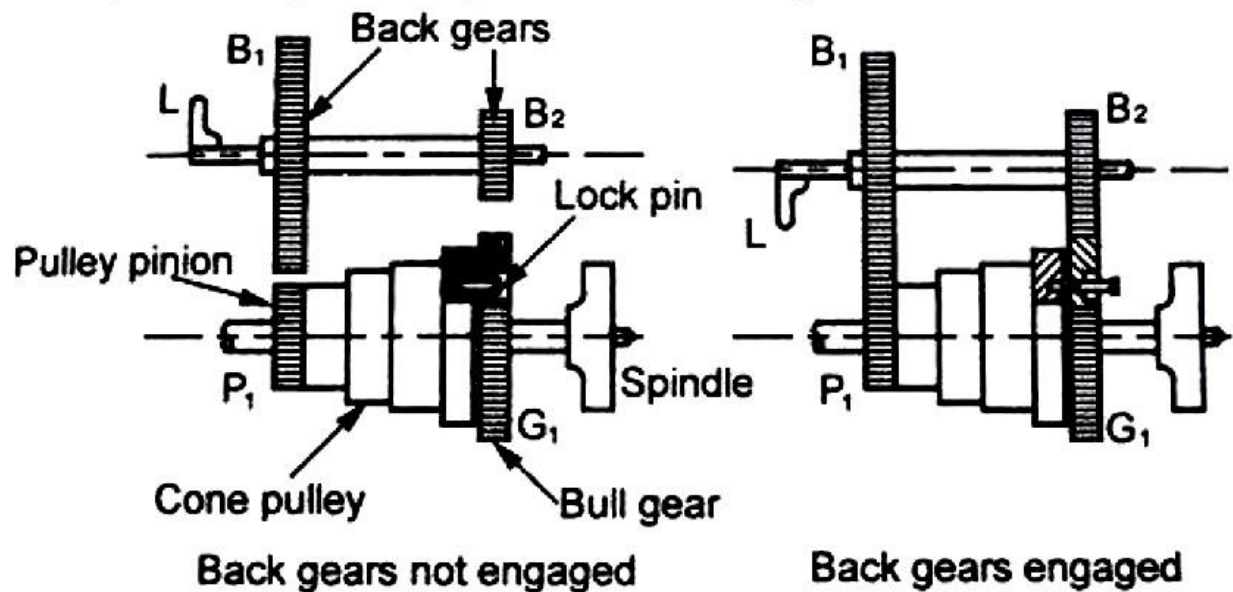

Fig. Back geared headstock

- Back gear arrangement is used for reducing the spindle speed, which is necessary for thread cutting and knurling.
- There is one stepped cone pulley in the lathe spindle. This pulley can freely rotate on the spindle.
- A pinion gear P1 is connected to small end of the cone pulley. P1 will rotate when cone pulley rotates.
- Bull gear G1 is keyed to lathe spindle such that the spindle will rotate when Gear G1 rotates.
- Speed changes can be obtained by changing the flat belt on the steps. A bull gear G1 may be locked or unlocked with this cone pulley by a lock pin.
- There are two back gears B1 and B2 on a back shaft. It is operated by means of hand lever L; back gears B1 and B2 can be engaged or disengaged with G1 and P1.
- For getting direct speed, back gear is not engaged. The step cone pulley is locked with the main spindle by using the lock pin. The flat belt is changed for different steps. Thus three or four ranges of speed can be obtained directly.
- For getting slow or indirect speeds, back gear is engaged by lever L and lock pin is disengaged.
- Now, power will flow from P1 to B1. B1 to B2 (same shaft), B2 to G1 to spindle. As gear B1 is larger than P1, the speed will further be reduced at B1.
- B1 and B2 will have the same speeds. The speed will further be reduced at G1 because gear G1 is larger than B2. So, the speed of spindle is reduced by engaging the back gear.

b. All geared headstock:

The All geared Headstock is shown in figure below:

All geared headstock is commonly used in modern lathes because of the following advantages:

- It gives wider range of spindle speeds.
- It is more efficient and compact than cone pulley mechanism.
- Power available at the tool is almost constant for all spindle speeds.
- Belt shifting is eliminated.
- The vibration of the spindle is reduced.
- More power can be transmitted.

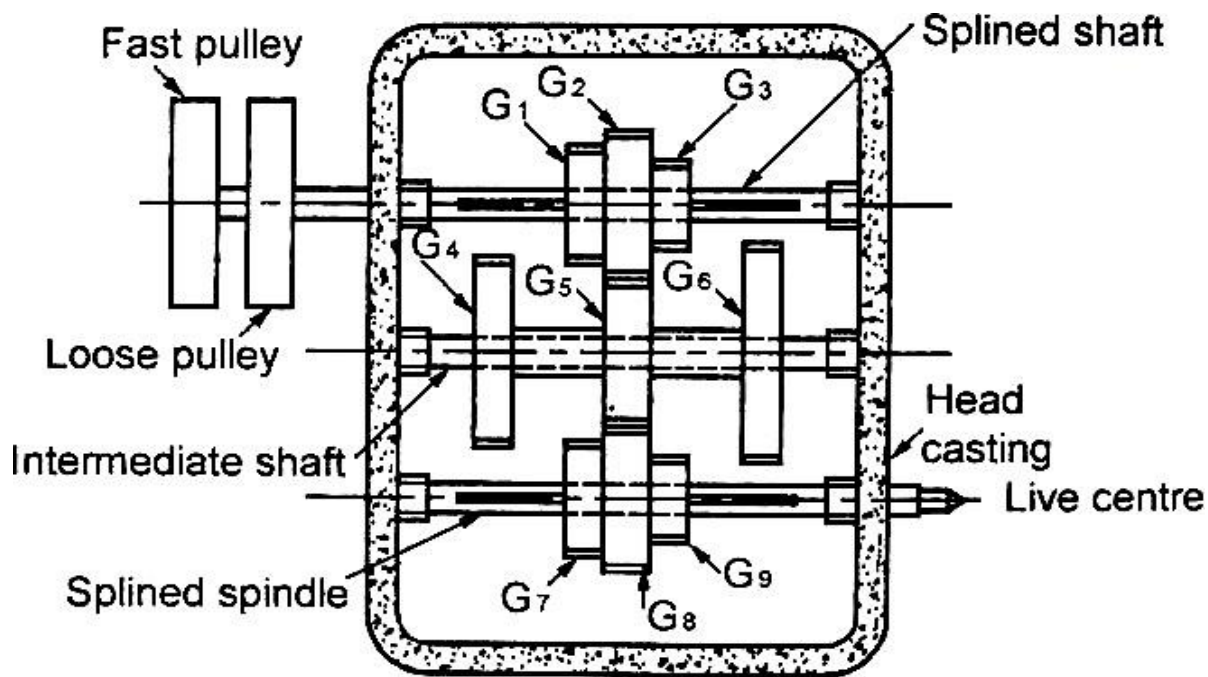

Fig. All geared headstock

CONSTRUCTION AND WORKING

- The power from the constant speed motor is delivered to the spindle through a belt drive. Speed changing is made by levers.
- The different spindle speeds are obtained by shifting the levers into different positions to obtain different gear combinations.
- This mechanism has a splined spindle, intermediate shaft and a splined shaft. The splined shaft receives power from motor through a belt drive.
- This shaft has 3 gears namely G1, G2 and G3. These gears can be shifted with the help of lever along the shaft.
- Gears G4, G5 and G6 are mounted on intermediate shaft and cannot be moved axially.
- Gears G7, G8 and G9 are mounted on splined headstock spindle and can be moved axially by levers.
- Gears G1, G2 and G3 can be meshed with the gears G4, G5 and G6 individually.
- Similarly, gears G7, G8, G9 can be meshed with gear G4, G5 and G6 individually. Thus, it provides nine different speeds.

4. Explain in detail of Feed mechanisms

Feed mechanisms

The feed mechanism is used to transmit power from the spindle to the carriage. Therefore, it converts rotary motion of the spindle into linear motion of the carriage. The feed can be given either by hand or automatically. For automatic feeding, the following feed mechanisms are used:

- Tumbler gear reversing mechanism.
- Quick-change gearbox.
- Tumbler gear quick-change gearbox.
- Apron mechanism.
- Bevel gear feed reversing mechanism.

a.) Explain in detail of Tumbler gear reversing mechanism

Tumbler gear mechanism is used to change the direction of lead screw and feed rod. By engaging tumbler gear, the carriage can be moved along the lathe axis in either direction during thread cutting or automatic machining.

- The tumbler gear unit has two pinions (A and B) of same size and is mounted on a bracket. The bracket is pivoted at a point and can be moved up and down by a lever L.
- The bracket may be placed in three positions i.e., upward, downward and neutral. Gear „C“ is a spindle gear attached to the lathe spindle.
- Gear „D“ is the stud gear. The stud gear is connected to the lead screw gear through a set of intermediate gears.
- When the lever is shifted upward position, the gear „A“ is engaged with spindle gear „C“ and the power is transmitted through C-A-D-E-F. During this position, lead screw will rotate in the same direction as spindle rotates (i.e. both anticlockwise). Now, the carriage moves towards the headstock.
- When the lever is shifted downward, the gear „B“ is engaged with spindle gear „C“ and the power is transmitted through C-B-A-D-E-F. Hence, the lead screw will rotate in the opposite direction of the spindle. Now, the carriage moves towards tailstock.
- When the bracket is in neutral position, the engagement of tumbler gears is disconnected with the spindle gear. Hence, there is no power transmission to lead screw.

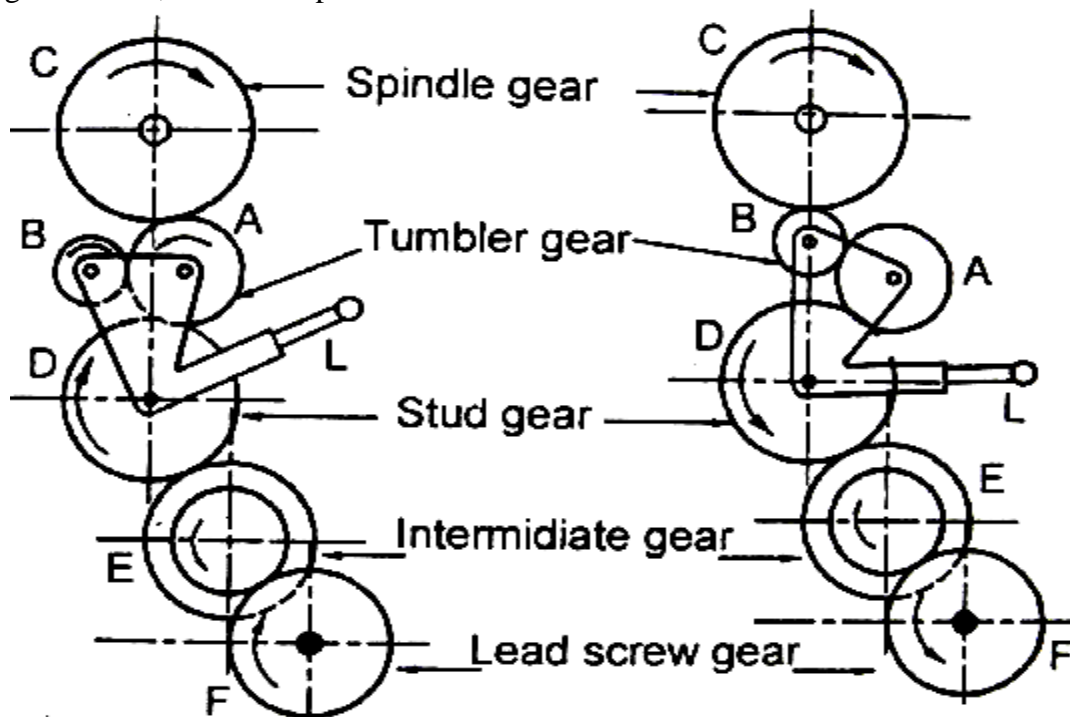

Fig. 2.5 Tumbler gear reversing mechanism

b.) Explain in detail of Quick-change gear box.

- Quick-change gearbox is used to get various power feeds in the lathe.
- Power from the lathe spindle is transmitted to feed shaft through tumbler gear, change gear train and quick-change gearbox.

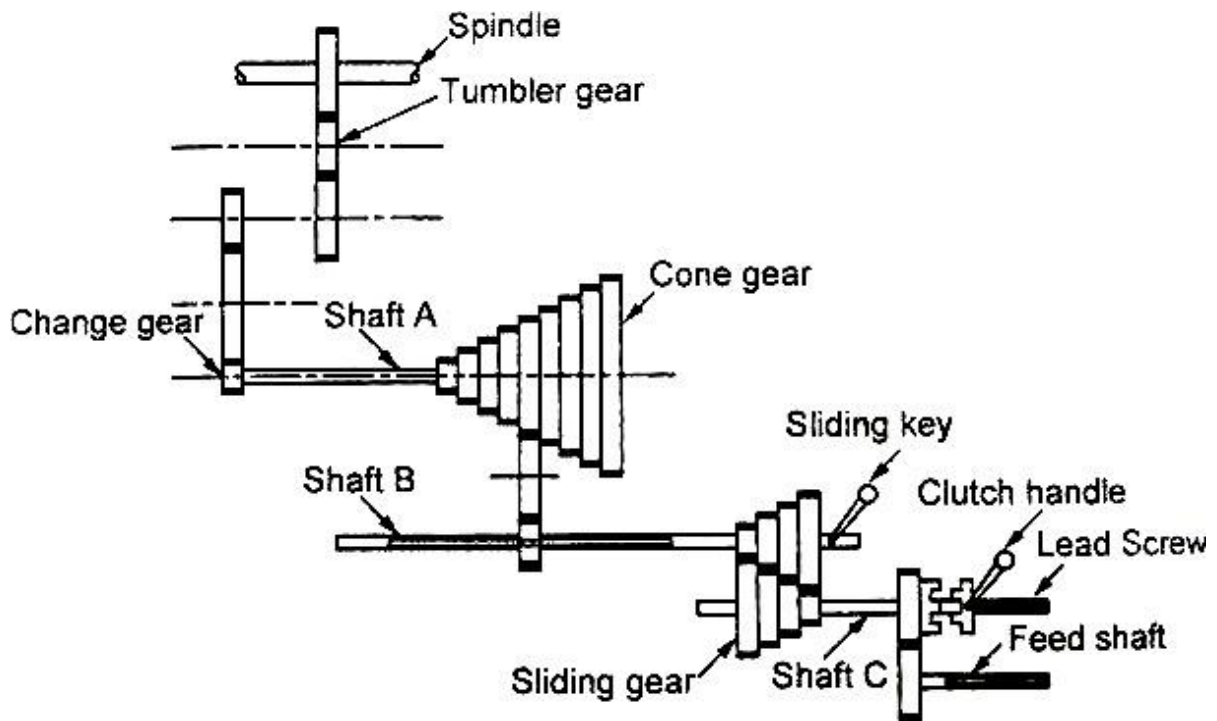

Fig. Quick-change gear box

- Shaft A (Cone gear shaft) contains 9 different sizes of gears keyed with it.
- Shaft B (Sliding gear shaft) has a gear and it receives 9 different speeds from shaft A by the use of sliding gear.
- Shaft B is connected to shaft C (Driven shaft) through 4 cone drives. Therefore, Shaft C can get $9 \times 4 = 36$ different speeds.
- The shaft C is connected to lead screw by a clutch and feed rod by a gear train. Lead screw is used for thread cutting and feed rod is used for automatic feeds.

c.) Explain in detail of Tumbler gear quick-change gear box

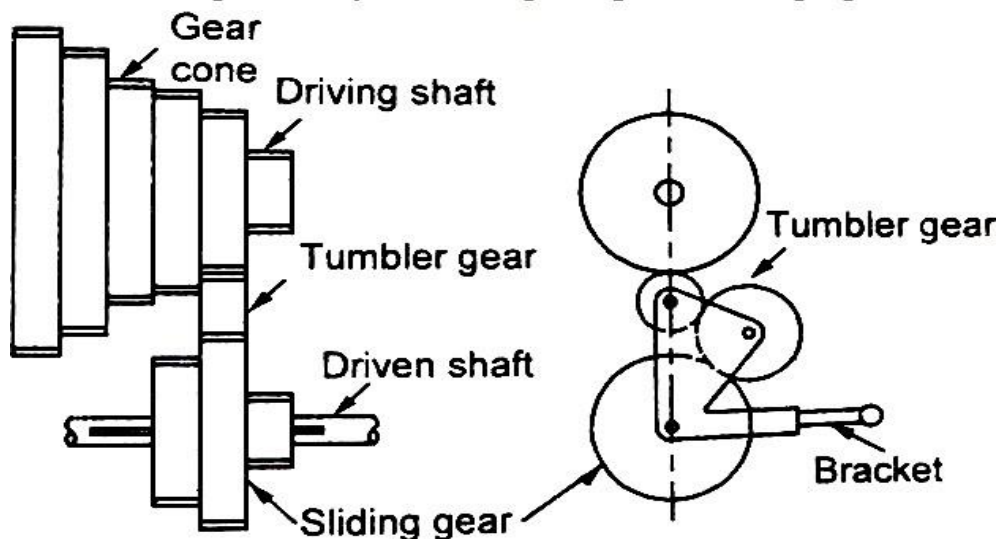

Fig. Tumbler gear quick-change gearbox

- The different speed of the driving shaft is obtained by a tumbler gear and cone gear arrangement.
- It is simpler than quick-change gearbox. A tumbler gear and a sliding gear are attached to the bracket as shown in Fig.

- Driving shaft has a cone gear made up of different sizes of gears. The sliding gear is keyed to the driven shaft which is connected by the lead screw or feed rod. The sliding gear can be made to slide and engaged at any desired position.
- By sliding the sliding gear to various positions and engaging the tumbler gear, various speeds can be obtained.

d.) Explain in detail of Apron mechanism.

- Lead screw and feed rod is getting power from spindle gear through tumbler gears. Power is transmitted from feed rod to the worm wheel through gears A, B, C, D and worm.
- A splined shaft is attached with worm wheel. The splined shaft is always engaged with the gears F and G which are keyed to the feed check shaft. A knob „E“ is fitted with feed check shaft. Feed check knob „E“ can be placed in three positions such as neutral, push-in and pull-out.
- When the feed check knob „E“ is in neutral position, power is not transmitted either to cross feed screw or to the carriage since gears F and G have no connection with H and K. Therefore, hand feed is given as follows.
- When the longitudinal feed hand wheel rotates, pinion I will also be rotated through I and H. pinion I will move on rack for taking longitudinal feed. For getting cross feed, cross slide screw will be rotated by using cross slide hand wheel.
- When the feed check knob „E“ is push-in, rotating gear G will be engaged to H. Then the power will be transmitted to pinion I. pinion I will rotate on rack. So, automatic longitudinal feed takes place.
- When the feed check knob „E“ is pulled-out, the rotating gear F will be engaged to K. Hence, the power will be transmitted to cross feed screws through L. This leads to automatic cross feed.

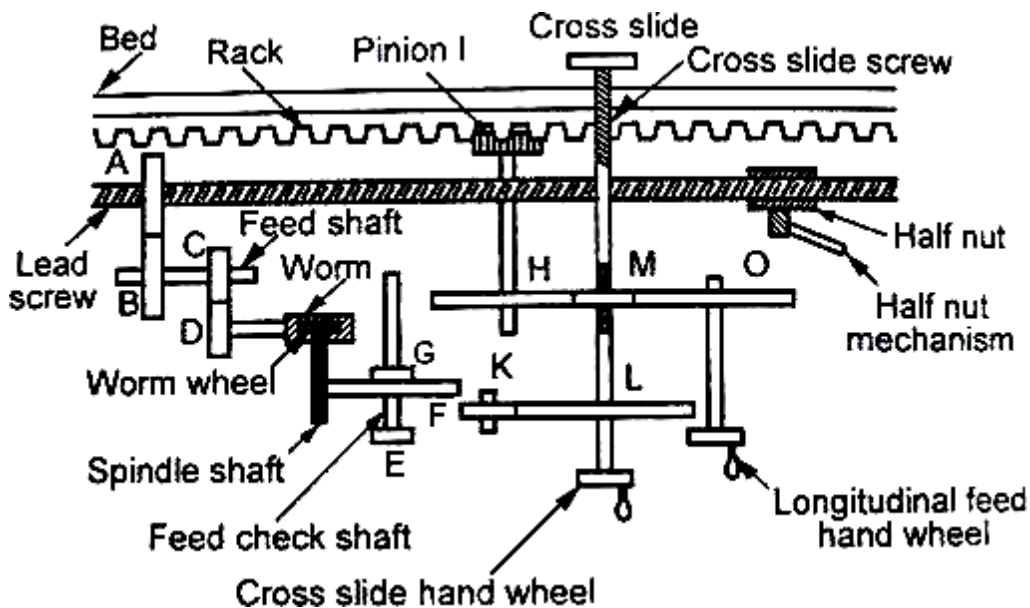

Fig. Apron mechanism

- For thread cutting, half nut is engaged by half nut lever after putting knob „E“ neutral position.
- Half nut is firmly attached with the carriage. As the lead screw rotates, the carriage will automatically move along the axis of the lathe. Both longitudinal and cross feed can be reversed by operating the tumbler gear mechanism.

e.) Explain in detail of Bevel gear feed reversing mechanism

- The tumbler gear mechanism being a non-rigid construction cannot be used in a modern heavy duty lathe. The clutch operated bevel gear feed reversing mechanism incorporated below the head stock or in apron provides sufficient rigidity in construction.
- The motion is communicated from the spindle gear 2 to the gear on the stud shaft through the intermediate gear. The bevel gear 8 is attached to the gear on the stud shaft and both of them can freely rotate on shaft 7.

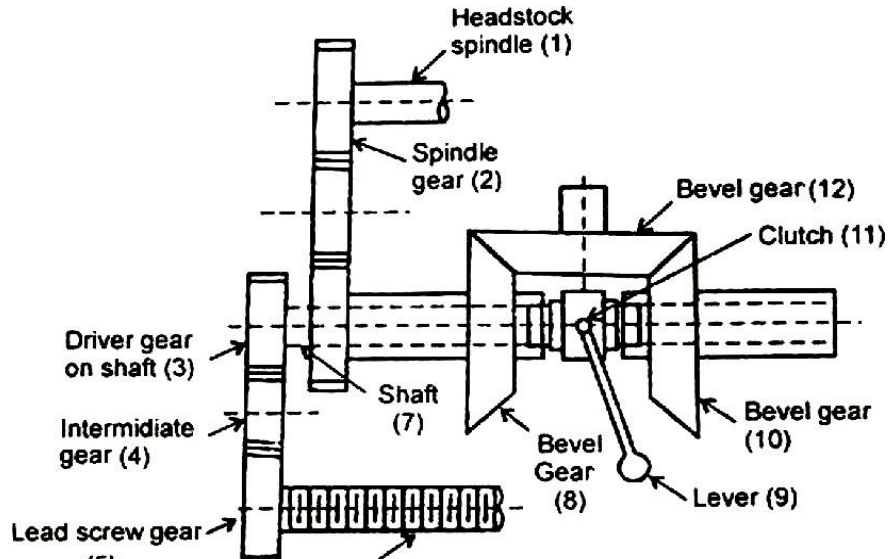

Fig. Bevel gear feed reversing mechanism

- The bevel gear 8 meshes with bevel gear 12 and 12 mesh with 10. 12, 10 and 8 are having equal number of teeth. The bevel gear 10 can also rotate freely on shaft 7.
- A clutch 11 is keyed to the shaft 7 by a feather key and may be shifted to left or right, by the lever 9 to be engaged with the gear 8 or 10 or it remains in the neutral position.
- When the clutch engages with bevel gear 8, gear 3 which is keyed to the shaft 7 and the lead screw, rotates in the same direction as the gear 2. The direction of rotation is reversed when the clutch 11 engages with gear 10.

6. Explain the Mounting of jobs in centre lathe. Without additional support from the tailstock

Chucks:

There are two types of chucks

Three jaw chuck

Four jaw chuck

Three jaw chuck

- It has three jaws, when the chuck key is turned, all jaws will move for equal distance in the radial direction.
- The chuck has an internal mechanism to simultaneously move three jaws. Hence the work can automatically be centered and quickly.

Four jaw chuck

- The four jaw chucks, available in varying sizes, are generally used for essentially more strongly holding non-circular bars like square, rectangular, hexagonal and even odder sectional jobs in addition to cylindrical bars, both with and without premachining at the gripping portion.

- The jaws are moved radially independently by rotating the corresponding screws which push the rack provided on the back side of each jaw as can be seen in the diagram. 4 jaws independent chuck which are mounted at the spindle nose and firmly hold the job in centre lathes.

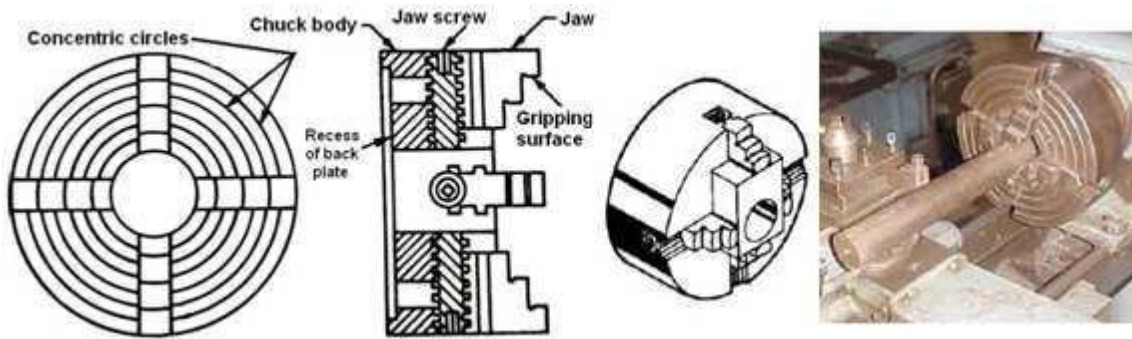

Fig. (a) 3-jaw self centering chuck or universal chuck

Fig. (b) 4-jaw independent chuck

Magnetic chuck

This is used for holding thin jobs. When the pressure of jaws is to be prevented, this chuck is used. The chuck gets magnetic power from an electro-magnet. Only magnetic materials can be held on this chuck.

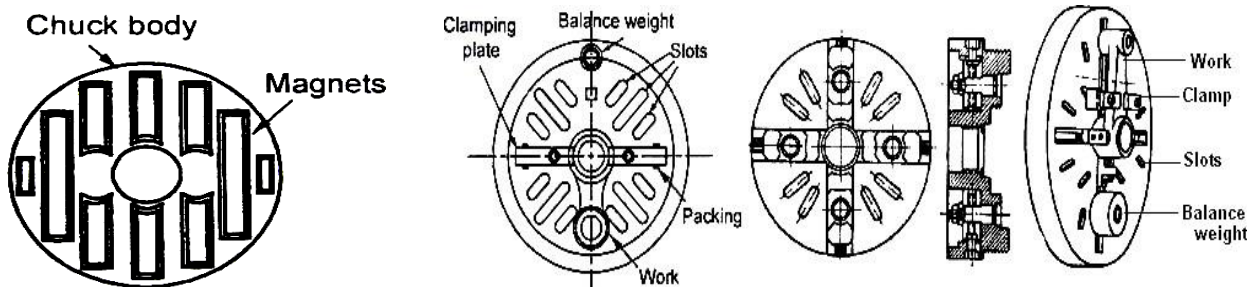

Fig. Magnetic chuck

Fig. Face plate

Face plate

A face plate consists of a circular disc bored out and threaded to fit the nose of lathe spindle. This has radial, plain and T slots for holding work by bolts and clamps. Face plates are used for holding work pieces which cannot be conveniently held between centres or by chucks.

Angle plate

Angle plate is a cast iron plate that has two faces at right angles to each other. Holes and slots are provided on both faces as shown in Fig.(a). An angle plate is used along with the face plate when holding eccentric or unsymmetrical jobs that are difficult to grip directly on the face plate.

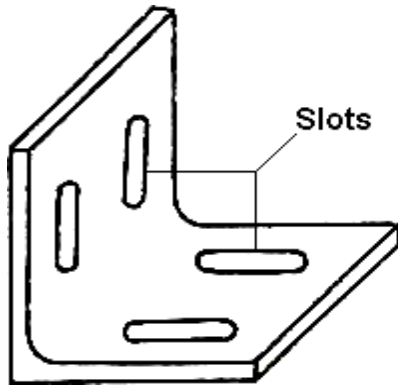

Fig. (a) Angle plate

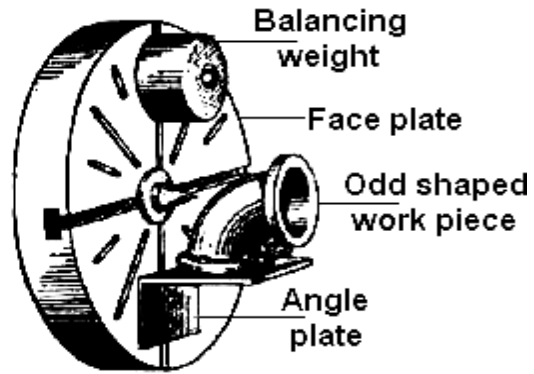

Fig. (b) Angle plate used along with face plate

WITH ADDITIONAL SUPPORT FROM THE TAILSTOCK

Catch plate or driving plate

- It is circular plate of steel or cast iron having a projected boss at its rear.
- The boss has a threaded hole and it can be screwed to the nose of the headstock spindle.
- The driving is fitted to the plate. It is used to drive the work piece through a carrier or dog when the work piece is held between the centres.

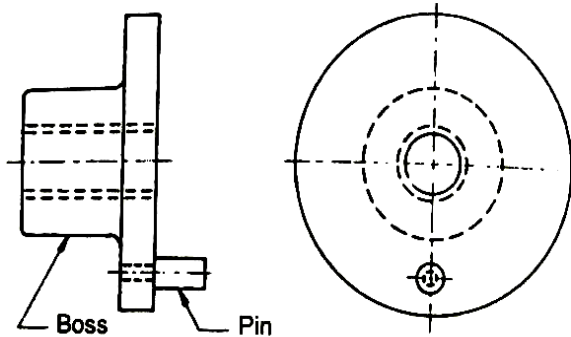

Fig. Catch plate.

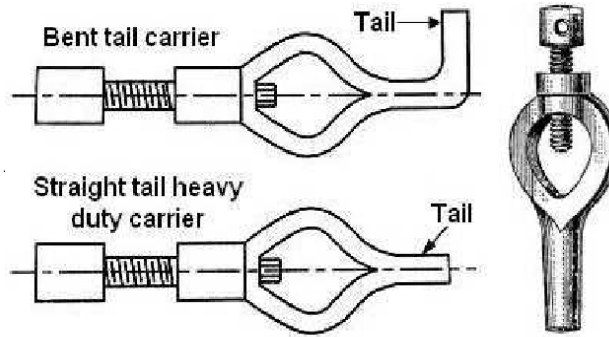

Fig. Types of carriers

Carriers or Dogs

- It is used to transfer motion from the driving plate to the work piece held between centres.
- The work piece is inserted into the hole of the dog and firmly secured in position by means of set screw.

Mandrels

- A mandrel is a device used for holding and rotating a hollow work piece that has been previously drilled or bored. The work revolves with the mandrel which is mounted between two centers.
- The mandrel should be true with accurate centre holes for machining outer surface of the work piece concentric with its bore. To avoid distortion and wear it is made of high carbon steel.

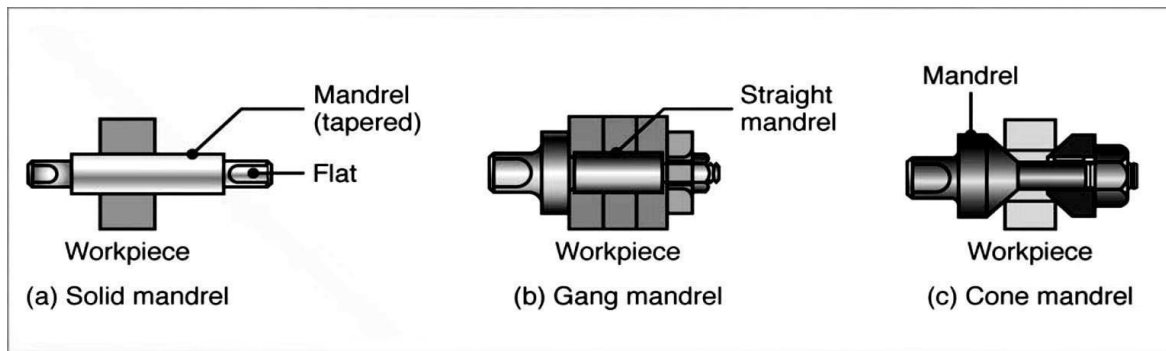

- The ends of a mandrel are slightly smaller in diameter and flattened to provide effective gripping surface of the lathe dog set screw.
- The mandrel is rotated by the lathe dog and the catch plate and it drives the work by friction. Different types of mandrels are employed according to specific requirements.

In-between centres (by catch plate and carriers)

- Long slender rods are held in between the live centre fitted into the headstock spindle and the dead centre fitted in the quill of the tailstock.
- The torque and rotation are transmitted from the spindle to the job with the help of a lathe dog or catcher which is again driven by a driving plate fitted at the spindle nose.
- Depending upon the situation or requirement, different types of centres are used at the tailstock end as indicated.
- A revolving centre is preferably used when desired to avoid sliding friction between the job and the centre which also rotates along with the job.

Types of centres

- **Ordinary centre:** It is used for general works.
- **Insert type centre:** In this the steel “insert” can be replaced instead of replacing the whole centre.
- **Half centre:** It is similar to ordinary centre and used for facing bar ends without removal of the centre.
- **Pipe centre:** It is used for supporting pipes and hollow end jobs.
- **Ball centre:** It has ball shaped end to minimize the wear and strain. It is suitable for taper turning.
- **Tipped centre:** Hard alloy tip is brazed into steel shank. The hard tip has high wear resistant.
- **Revolving centre:** The ball and roller bearings are fitted into the housing to reduce friction and to take up end thrust. This is used in tail stock for supporting heavy work revolving at a high speed.

7. Explain cutting tools and its working.

CUTTING TOOLS

For general purpose work, a single point cutting tool is used in centre lathes. But for special operations multi point tools may be used. Single point lathe tools are classified as follows:

According to the method of manufacturing the tool

- Forged tool.
- Tipped tool brazed to the carbon steel shank.
- Tipped tool fastened mechanically to the carbon steel shank.

According to the method of holding the tool

- Solid tool.
- Tool bit inserted in the tool holder.

According to the method of using the tool

Turning tool, facing tool, forming tool, chamfering tool, finish turning tool, round nose tool, external thread tool, internal thread tool, boring tool, parting tool, knurling tool, etc.

According to the method of applying feed

- Right hand tool.
- Left hand tool.
- Round nose tool.

VARIOUS OPERATIONS

8. Discuss any two operations that can be performed in a lathe. (April/May 2015)

The machining operations generally carried out in centre lathe are:

- **Straight turning** – Straight turning is the operation of producing cylindrical surface by removing material from the outside diameter of the work piece. It is done by rotating the work piece about the lathe axis and feeding the tool parallel to the lathe axis.
- **Facing** - Machining the end of the work piece to produce flat surface is called facing. The work may be held in a chuck or between centers. The work is rotated about the lathe axis. A facing tool is fed perpendicular to the axis of the lathe. The feeding may be done by the hand or power.
- **Centering** – when the work is required to be turned between centers, conical shapes holes must be provided at both ends of the work piece to provide the bearing surface for the lathe centers. The operation of producing conical holes on both ends of the work piece.
- **Chamfering** - The operation of beveling or turning a slope at the end of the work piece. It is done for removing burrs and blends the sharp edges. Generally, the chamfering is done for jobs after knurling, rough turning and thread cutting operations. A chamfering tool is moved perpendicular to the lathe axis.
- **Shouldering** - The operation of turning the shoulders of the stepped diameter work piece.
- **Grooving** - The operation of reducing the diameter of the work piece over a narrow surface. It is also called as recessing, undercutting or necking. It is generally done at the end of the thread or adjacent to a shoulder.
- **Drilling** – Drilling is the operation of producing a cylindrical hole in a work piece. It is done by rotating the cutting edge of a cutter is known as drilling.
- **Boring** – Boring is the operation of enlarging the diameter of a drilled holes. Boring is used when the correct size drill is not available. Boring is not used to make a hole but it corrects the size of a hole.
- **Forming** – Forming is the process of producing concave, convex and any irregular shape on the work piece by a form tool. The cutting edge of the tool is ground to the required form.
- **Parting off** – It is the process of cutting the work piece into two halves. For this operation, the carriage is locked at the required position and the spindle speed should be reduced to half of the speed of turning. The tool is slowly fed perpendicular to the lathe axis.
- **Knurling** – knurling is the process of producing a diamond shaped pattern or impression on the surface of the work piece. It is used to give a good gripping surface to the work piece. It is also slightly done to increase the diameter of the work piece. A knurling tool is used to produce knurled surfaces.
- **Milling** – Milling is the operation of removing metal by rotating the cutter having multiple cutting edges. Small milling cutters are held in the headstock and revolved.

- **Thread cutting** – Thread cutting is the operation of producing a helical groove on the cylindrical work piece. When the job rotates, the tool automatically fed in the longitudinal direction by using locknut and lead screw arrangements.

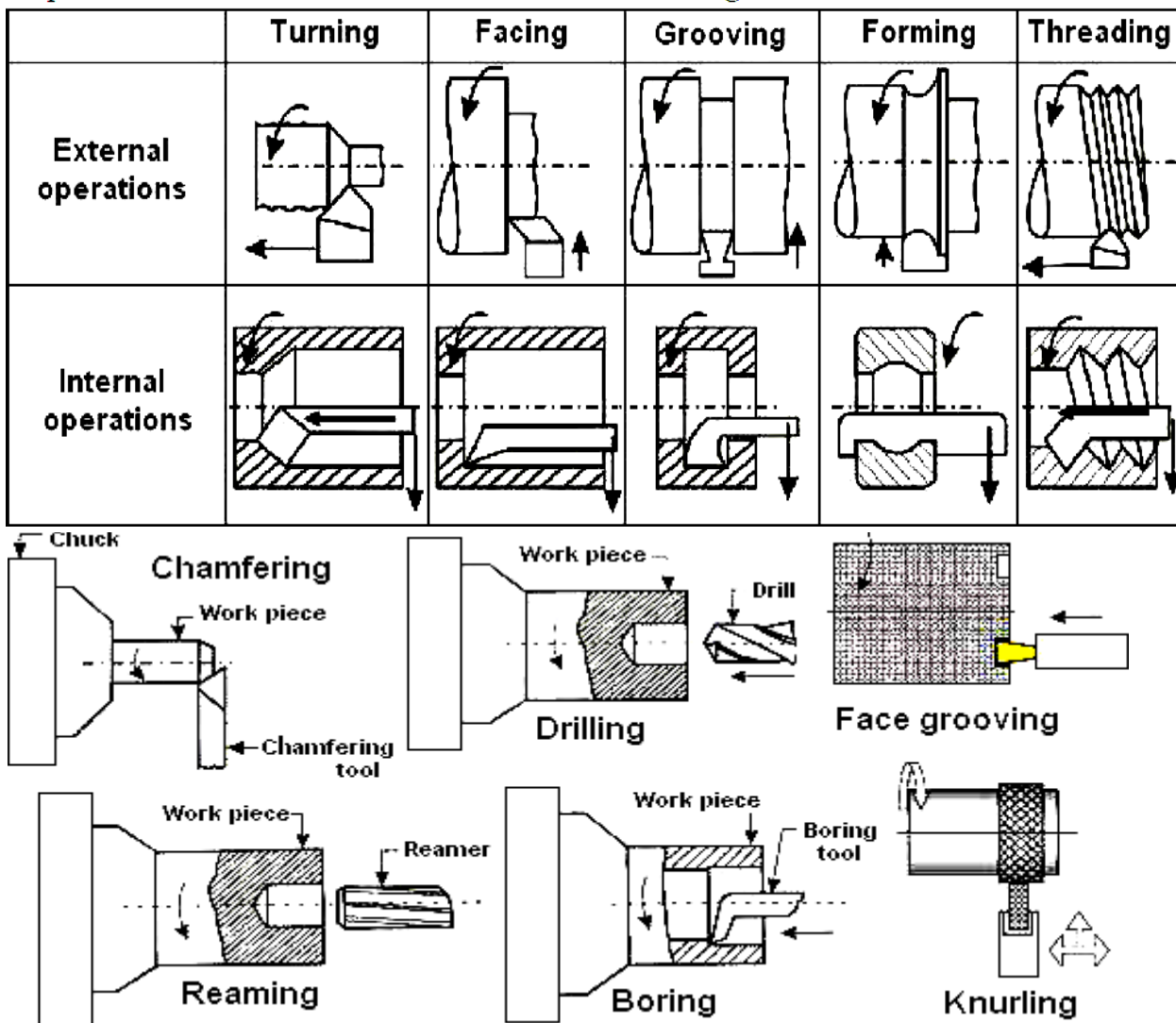

Fig. Some common machining operations carried out in a centre lathe

9. Explain taper turning methods. (Dec 2006)

TAPER TURNING METHODS

A taper may be defined as a uniform change in the diameter of a work piece measured along its length. Taper may be expressed in two ways:

- Ratio of difference in diameter to the length.
- In degrees of half the included angle.

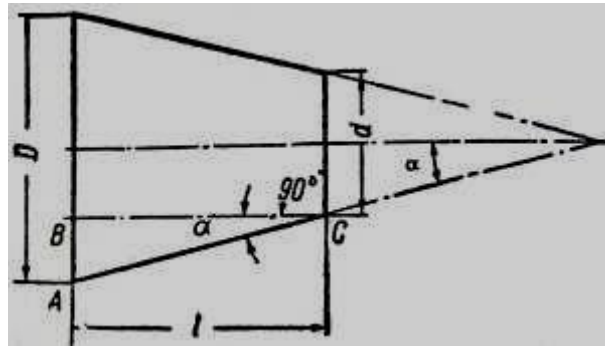

Fig. shows the details of a taper.

D - Large diameter of the taper.

d - Small diameter of the taper.

l - Length of tapered part.

α - Half angle of taper.

Generally, taper is specified by the term conicity. *Conicity is defined as the ratio of the difference in diameters of the taper to its length.* Conicity,

$$K = \frac{D - d}{l}$$

Taper turning is the operation of producing conical surface on the cylindrical work piece on lathe.

Taper turning by a form tool

- The Fig. illustrates the method of turning taper by a form tool.
- A broad nose tool having straight cutting edge is set on to the work at half taper angle, and is fed straight into the work to generate a tapered surface.
- In this method the tool angle should be properly checked before use. This method is limited to turn short length of taper only.
- This is due to the reason that the metal is removed by the entire cutting edge will require excessive cutting pressure, which may distort the work due to vibration and spoil the work surface.

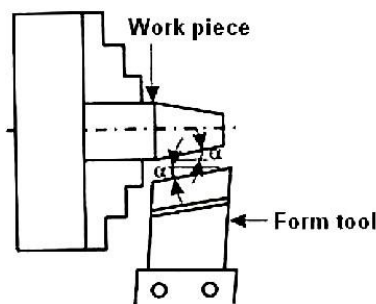

Fig. Taper turning by a form tool

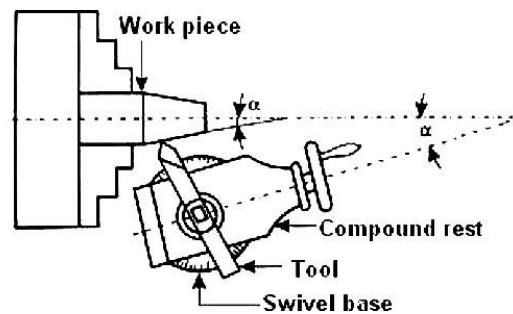

Fig. Taper turning by swiveling the compound rest

Taper turning by swiveling the compound rest

- In this method is used to produce short and steep taper.
- In this method, work is held in a chuck and is rotated about the lathe axis. The compound rest is swiveled to the required angle and clamped in position.
- The angle is determined by using the formula,

$$\tan \alpha = \frac{D - d}{2l}$$

- Then the tool is fed by the compound rest hand wheel. This method is used for producing both internal and external taper.
- This method is limited to turn a short taper owing to the limited movement of the compound rest. The compound rest may be swivelled at 45° on either side of the lathe axis enabling it to turn a steep taper.
- The movement of the tool in this method being purely controlled by hand, this gives a low production capacity and poorer surface finish.

Taper turning by offsetting the tailstock

- The principle of turning taper by this method is to shift the axis of rotation of the work piece, at an angle to the lathe axis, which is equal to half angle of the taper, and feeding the tool parallel to the lathe axis.
- This is done when the body of the tailstock is made to slide on its base towards or away from the operator by a set over screw. The amount of set over being limited, this method is suitable for turning small taper on long jobs.
- The main disadvantage of this method is that live and dead centres are not equally stressed and the wear is not uniform. Moreover, the lathe carrier being set at an angle, the angular velocity of the work is not constant.

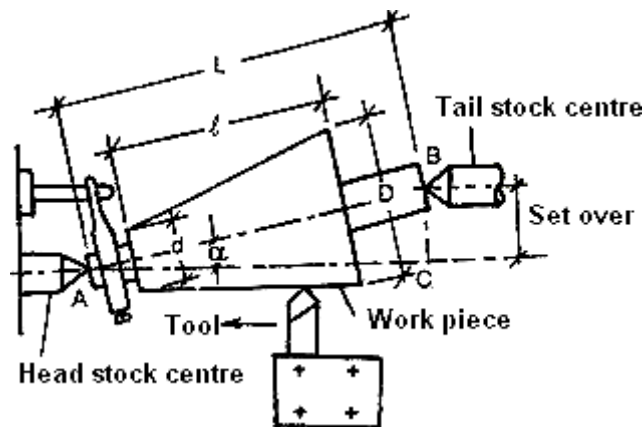

Fig. Taper turning by offsetting the tailstock

The amount of set over required to machine a particular taper may be calculated as:

From the right angle triangle ABC in Fig;

$$BC = AB \sin \alpha, \text{ where } BC = \text{set over}$$

$$\text{Set over} = L \sin \alpha$$

If the half angle of taper (α), is very small, for all practical purposes, $\sin \alpha = \tan \alpha$

$$\text{Set over} = L \tan \alpha = L \times \frac{D - d}{2l} \text{ in mm.}$$

If the taper is turned on the entire length of the work piece, then $l = L$, and the equation becomes:

$$\text{Set over} = L \times \frac{D - d}{2L} = \frac{D - d}{2}$$

being termed as the conicity or amount of taper, the formula (2.4) may be written in the following form:

$$\text{Set over} = \frac{\text{entire length of the work} \times \text{conicity}}{2}$$

Taper turning by using taper turning attachment

- It consists of a bracket or frame which is attached to the rear end of the lathe bed and supports a guide bar pivoted at the centre.
- The guide bar having graduations in degrees may be swiveled on either side of the zero graduation and is set at the desired angle with the lathe axis. When this attachment is used the cross slide is delinked from the saddle by removing the binder screw.
- The rear end of the cross slide is then tightened with the guide block by means of a bolt. When the longitudinal feed is engaged, the tool mounted on the cross slide will follow the angular path, as the guide block will slide on the guide bar set at an angle to the lathe axis. The required depth of cut is given by the compound slide which is placed at right angles to the lathe axis.
- The guide bar must be set at half taper angle and the taper on the work must be converted in degrees. The maximum angle through which the guide bar may be swiveled is 100 to 120 on either side of the centre line.

The advantages of using a taper turning attachment are:

- The alignment of live and dead centres being not disturbed; both straight and taper turning may be performed on a work piece in one setting without much loss of time.
- Once the taper is set, any length of work piece may be turned taper within its limit.
- Very steep taper on a long work piece may be turned, which cannot be done by any other method.
- Accurate taper on a large number of work pieces may be turned.
- Internal tapers can be turned with ease.

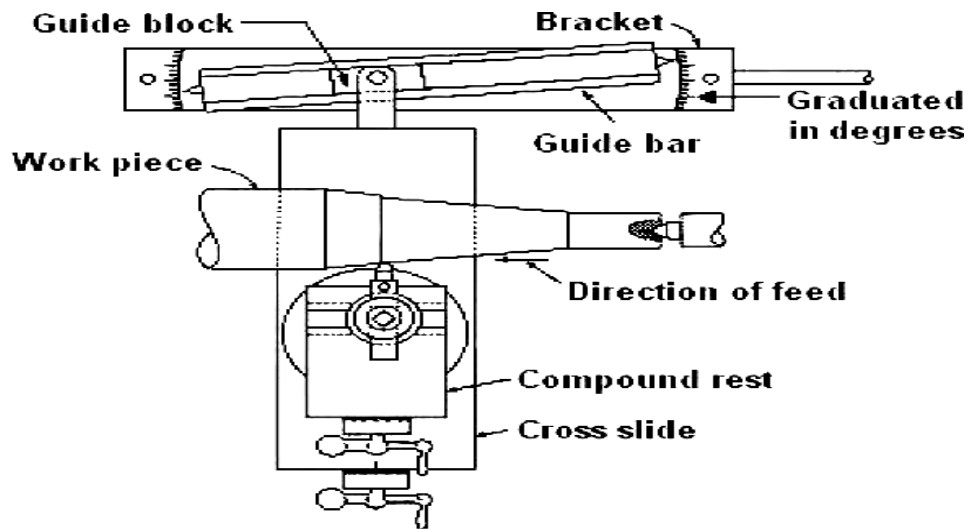

Fig. Taper turning attachment

THREAD CUTTING METHODS

- Thread cutting is one of the most important operations performed in a centre lathe. It is possible to cut both external and internal threads with the help of threading tools.
- There are a large number of thread forms that can be machined in a centre lathe such as Whitworth, ACME, ISO metric, etc.
- The principle of thread cutting is to produce a helical groove on a cylindrical or conical surface by feeding the tool longitudinally when the job is revolved between centres or by a chuck (for external threads) and by a chuck (for internal threads).

- The longitudinal feed should be equal to the pitch of the thread to be cut per revolution of the work piece.
- The lead screw of the lathe has a definite pitch. The saddle receives its traversing motion through the lead screw.
- Therefore a definite ratio between the longitudinal feed and rotation of the headstock spindle should be found out, so that the relative speeds of rotation of the work and the lead screw will result in the cutting of a thread of the desired pitch.
- This is effect by change gears arranged between the spindle and the lead screw or by the change gear mechanism or feed gear box used in a modern lathe.

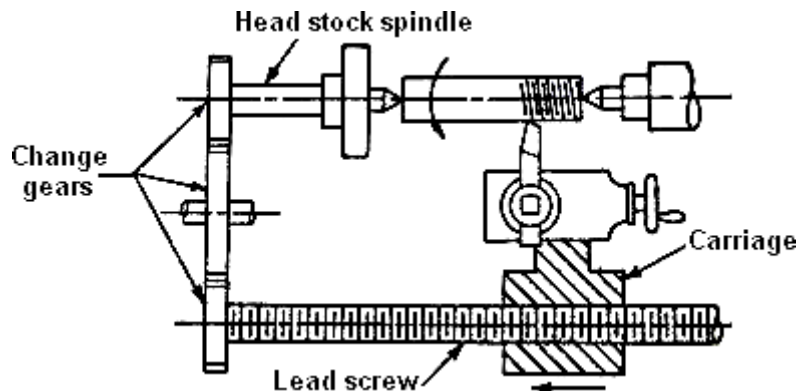

Fig. Principles of thread cutting

- Thread cutting on a centre lathe is a slow process, but it is the only process of producing square threads, as other methods develop interference on the helix.

Change gear ratio

- Centre lathes are equipped with a set of change gears. A typical set contains the following change gears with number of teeth: 20, 25, 30, 35, 40, 45, 50, 55, 60, 65, 70, 75, 80, 85, 90, 95, 100, 110, 120, 125 and 127.
- The change gear ratio must be transformed by multiplying numerator and denominator by a suitable number, to obtain gears available in the change gear set.
- The change gear ratio may result either in a „Simple gear train“ or „Compound gear train“.
- In modern lathes using quick change gears, the correct gear ratio for cutting a particular thread is quickly obtained by simply shifting the levers in different positions which are given in the charts or instruction plates supplied with the machine.

Thread cutting procedure

- The work piece should be rotated in anticlockwise direction when viewed from the tail stock end.
- The excess material is removed from the work piece to make its diameter equal to the major diameter of the screw thread to be generated.
- Change gears of correct size are fitted to the end of the bed between the spindle and the lead screw.
- The thread cutting tool is selected such that the shape or form of the cutting edge is of the same form as the thread to be generated. In a metric thread, the included angle of the cutting edge should be ground exactly 60°.
- A thread tool gauge or a centre gauge is used against the turned surface of the work piece to check the form of the cutting edge so that each face may be equally inclined to the centre line of the work piece.

- Then the tool is mounted in the tool post such that the top of the tool nose is horizontal and is in line with the axis of rotation of the work piece.
- The speed of the spindle is reduced by $\frac{1}{2}$ to $\frac{1}{4}$ of the speed required for turning according to the type of material being machined.
- The tool is fed inward until it first scratches the surface of the work piece. The graduated dial on the cross slide is noted or set to zero. Then the split nut or half nut is engaged and the tool moves along helical path over the desired length.
- At the end of tool travel, it is quickly withdrawn by means of cross slide. The split nut is disengaged and the carriage is returned to the starting position, for the next cut. These successive cuts are continued until the thread reaches its desired depth (checked on the dial of cross slide).

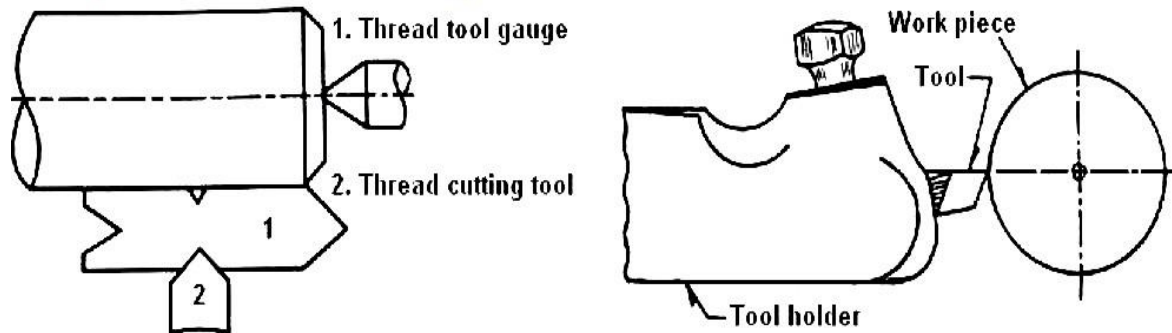

Fig. Checking of the cutting edge Fig. Mounting of the cutting tool

- For cutting left hand threads the carriage is moved from left to right (i.e. towards tail stock) and for cutting right hand threads it is moved from right to left (i.e. towards headstock).

Depth of cut in thread cutting

- The depth of first cut is usually 0.2 to 0.4 mm.
- This is gradually decreased for the successive cuts until for the final finishing cut; it is usually 0.025 to 0.075 mm.
- The depth of cut is applied by advancing the tool either radially (called as plunge cutting) or at an angle equal to half angle of the thread (called as compound cutting) (30° in case of metric threads) by swiveling the compound rest.

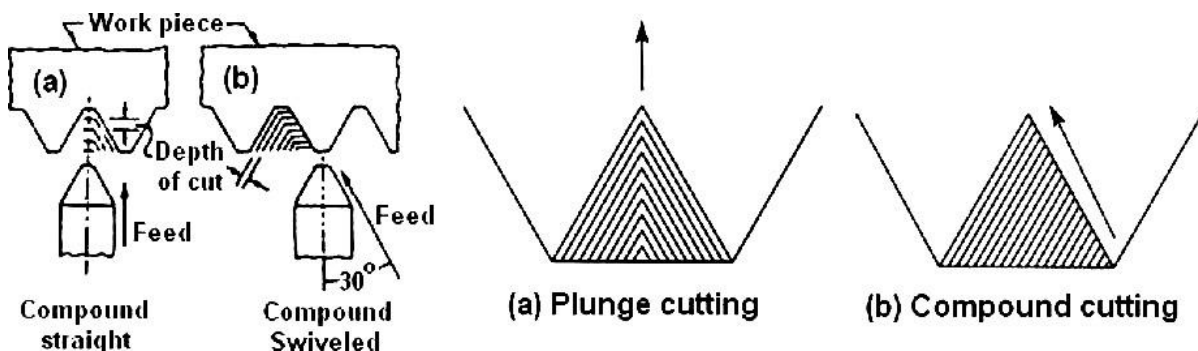

Fig. schematic view of the method of applying plunge cut and compound cut

Plunge cutting

In this, the absence of side and back rake will not produce proper cutting except on brass and cast iron. Cutting takes place along a longer length of the tool. This gives rise to difficulties in machining in terms of higher cutting forces and consequently chattering. This results in poor surface finish and lower tool life, thus this method is not generally preferred. This method is used for taking very light finishing cuts and for cutting square, acme and worm threads.

Compound cutting

Compound cutting is superior to the plunge cutting as it:

- Permits the tool to have a top rake.
- Permits cutting to take place on one edge of the tool only.
- Allows the chips to slide easily across the face of the tool without crowding.
- Reduces cutting strain that acts on the tool.
- Reduces the tendency to cause the tool to „dig-in“. So compound cutting is more preferred compared with plunge cutting.

Picking up the thread

- Several cuts are necessary before the full depth of thread is reached.
- It is essential that the tool tip should always follow the same thread profile generated in the first cut; otherwise the workpiece will be spoiled.
- This is termed as picking up the thread. The different methods of picking up the thread are:

Reversing the machine

- After the end of one cut the machine is reversed while keeping the half nut permanently engaged and retaining the engagement between the tool and the workpiece. The spindle reversal would bring the cutting tool to the starting point of the thread following the same path in reverse.
- After giving a further depth of cut the spindle is again reversed and the thread cutting is continued in the normal way.
- This is easy to work and is somewhat more time consuming due to the idle time involved in stopping and reversing of the spindle at the end of each stroke.

Marking the lathe parts

- The procedure is to mark the lead screw and its bracket, the large gear and the head stock casting, and the starting position of the carriage on the lathe bed.
- The aim is to bring each of the markings on the lead screw and gear opposite the markings on the stationary portions of the lathe, and have the carriage at the starting position before attempting to engage the split nut.

Using a chasing dial

- This is also called as thread indicator. This is a special attachment used in modern lathes for accurate “picking up” of the thread.
- This dial indicates when to close the split or half nuts. This is mounted on the right end of the apron.
- It consists of a vertical shaft with a worm gear engaged with the lead screw. The top of the vertical shaft has a revolving dial marked with lines and numbers to indicate equal divisions of the circumference. The dial turns with the lead screw so long the half nut is not engaged. If the half nut is closed and the carriage moves along, the dial stands still.

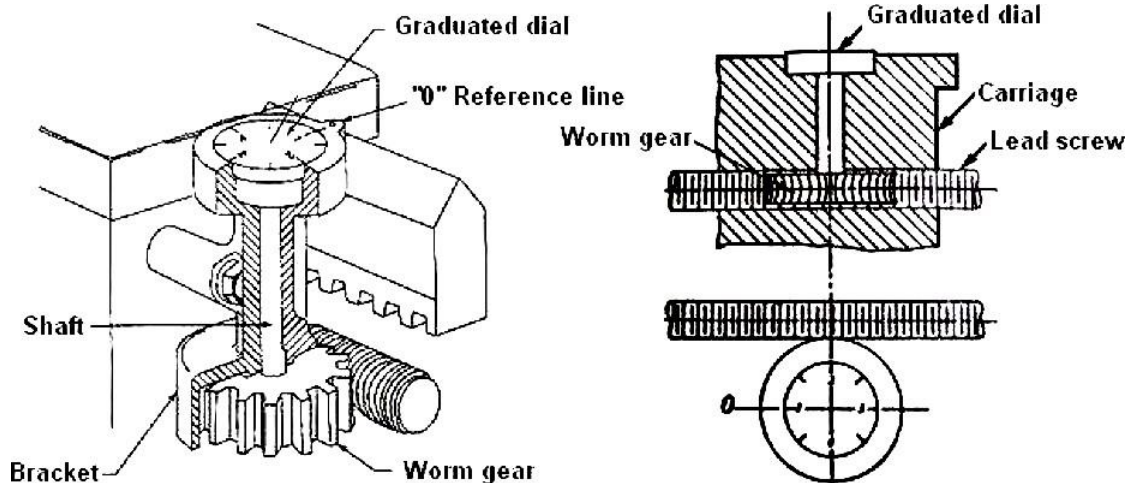

Fig. Thread chasing dial

- As the dial turns, the graduations pass a fixed reference line. The half-nut is closed for all even threads when any line on the dial coincides with the reference line.
- For all odd threads, the half-nut is closed at any numbered line on the dial coincides with the reference line. The corresponding number is determined from the charts.
- If the pitch of the thread to be cut is an exact multiple of the pitch of the lead screw, the thread is called even thread; otherwise the thread is called odd thread.

Thread chaser

- A chaser is a multipoint threading tool having the same form and pitch of the thread to be chased..

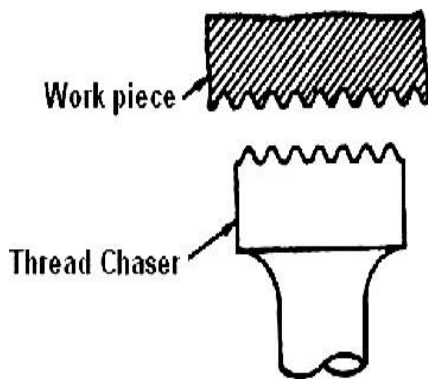

Fig.(a) External thread chaser

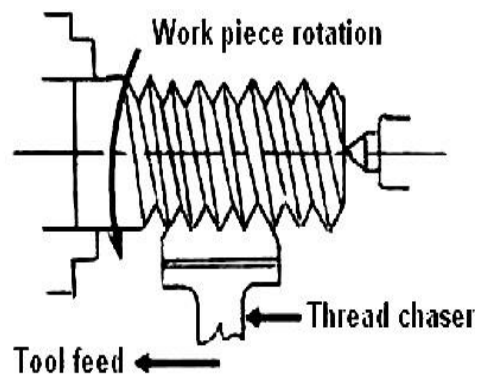

Fig.(b) Finishing of a partly cut thread

- A chaser is used to finish a partly cut thread to the size and shape required. Thread chasing is done at about $\frac{1}{2}$ of the speed of turning

10. Write short notes on special attachments.

SPECIAL ATTACHMENTS

- ❖ Each general purpose conventional machine tool is designed and used for a set of specific machining work on jobs of limited range of shape and size.
- ❖ But often some unusual work also need to be done in a specific machine tools, e.g. milling in a lathe, tapping in a drilling machine, gear teeth cutting in shaping machine and so on.

- ❖ Under such conditions, some special devices or systems are additionally used being mounted in the ordinary machine tools. Such additional special devices, which augment the processing capability of any ordinary machine tool, are known as attachments.

Milling attachment

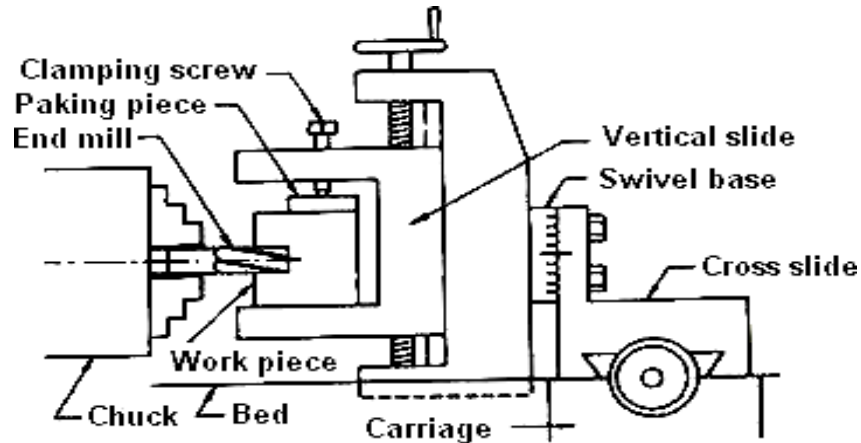

Fig. (a) End milling attachment

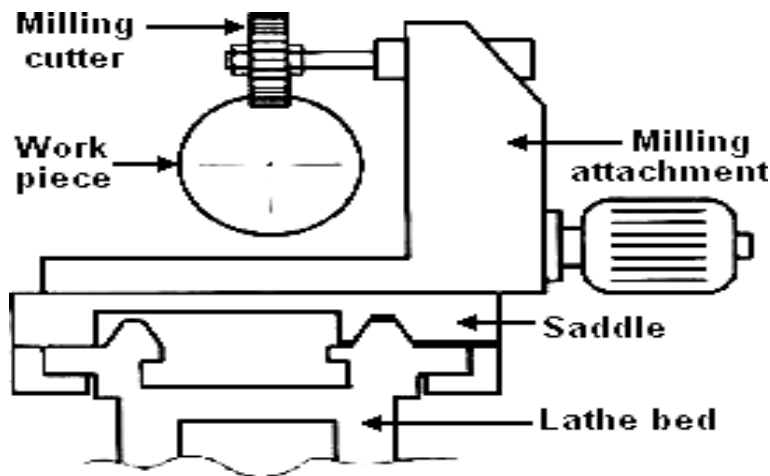

Fig. (b) Milling attachment

For cutting grooves or keyways, the work piece is held on the cross slide by using a special attachment and the end milling cutter is held in the chuck. Then the feed is given by a vertical slide provided on the special attachment.

For cutting multiple grooves and gear The attachment has a milling head, comprising a motor, a small gear box and a spindle to hold the milling cutter, mounted on the saddle after removing the cross slide etc. The work piece is held stationary between centres. Grooves are made on the periphery of the work piece by rotating the work piece. For cutting gears, a universal dividing head is fitted on the rear end of the headstock spindle to divide the work equally.

Cylindrical grinding attachment

- ❖ Grinding attachment is very similar to milling attachment. It has a bracket. It is mounted on the cross slide. A grinding wheel attached to the bracket is driven by a separate motor.
- ❖ The work piece may be held between centres or in a chuck. The grinding wheel is fed against the work piece. In this operation both work piece and grinding wheel rotate.

- ❖ By using this attachment both the external and internal grinding operation can be done.

MACHINING TIME AND POWER ESTIMATION

1. Machining time $T_m = L / fN$ min/pass

2. Power estimation

Power is the product of cutting force and velocity. In machining process, force component is nothing but the force in the direction of cutting speed. This only considered. Forces in the direction of feed and depth are too small when compared to the force in the direction of cutting speed. So, these two are insignificant. Force involved in orthogonal cutting is the force component in the direction of cutting speed.

E.g. turning, facing, parting-off operations, etc. so;

$$\text{Power required (} W_C \text{)} = F_C \times V$$

Where, V – Cutting speed (m/min) and

F_C – Force in the direction of cutting speed (N).

Due to shear and friction, the total power is divided into two components. They are;

1. Power due to shear.
2. Power due to friction.

So, Total power = Power due to shear + Power due to friction

$$W_C = W_s + W_f = [F_s \times V_s] + [F_f \times V_f]$$

Where, F_s – Force due to shear.

V_s – Velocity of shear.

F_f – Force due to friction.

V_f – Velocity of friction.

SPECIAL PURPOSE LATHES

The centre lathe is a general purpose machine tool; it has a number of limitations that preclude it to become a production machine tool.

The main limitations of centre lathes are:

- The setting time for the job in terms of holding the job is large.
- Only one tool can be used in the normal course. Sometimes the conventional tool post can be replaced by a square tool post with four tools.
- The idle times involved in the setting and movement of tools between the cuts is large.
- Precise movement of the tools to destined places is difficult to achieve if proper care is not taken by the operator.
- All these difficulties mean that the centre lathe cannot be used for production work in view of the low production rate. The centre lathe is thus modified to improve the production rate.

The various modified lathes are capstan and turret lathes, semi-automatics and automatics.

Improvements are achieved basically in the following areas:

- Work holding methods.
- Multiple tool availability.
- Automatic feeding of the tools.
- Automatic stopping of tools at precise locations.

- Automatic control of the proper sequence of operations.

11. Discuss the main parts of capstan and turret lathes. (May 2010)

Enumerate with neat diagram the principal parts of capstan and turret lathe. (April/May 2015)

CAPSTAN AND TURRET LATHES

Capstan and turret lathes are production lathes used to manufacture any number of identical pieces in the minimum time. These lathes are development of centre lathes. The capstan lathe was first developed in the year 1860 by Pratt and Whitney of USA.

In contrast to centre lathes, capstan and turret lathes:

- Are relatively costlier.
- Are requires less skilled operator.
- Possess an axially movable indexable turret (mostly hexagonal) in place of tailstock.
- Holds large number of cutting tools; up to four in indexable tool post on the front slide, one in the rear slide and up to six in the turret (if hexagonal) as indicated in the schematic diagrams.
- Are more productive for quick engagement and overlapped functioning of the tools in addition to faster mounting and feeding of the job and rapid speed change.
- Enable repetitive production of same job requiring less involvement, effort and attention of the operator for pre-setting of work-speed and feed rate and length of travel of the cutting tools.
- Are suitable and economically viable for batch production or small lot production.
- Capable of taking multiple cuts and combined cuts at the same time.

Major parts of capstan and turret lathes

Capstan and turret lathes are very similar in construction, working, application and specification. The major parts are:

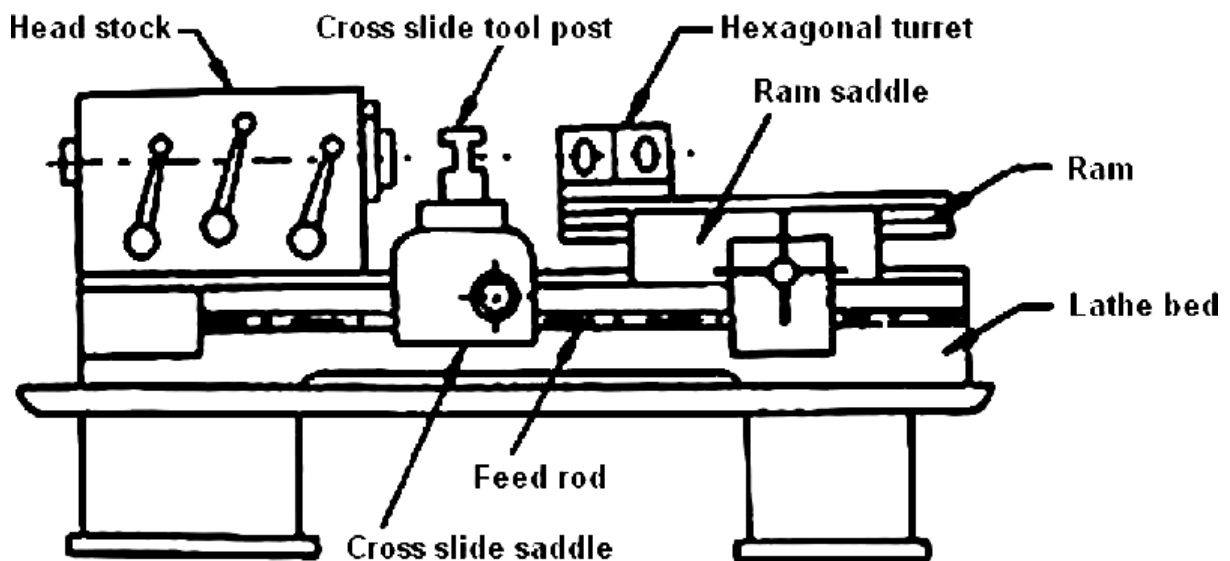

Fig. Basic configuration of a Capstan lathe

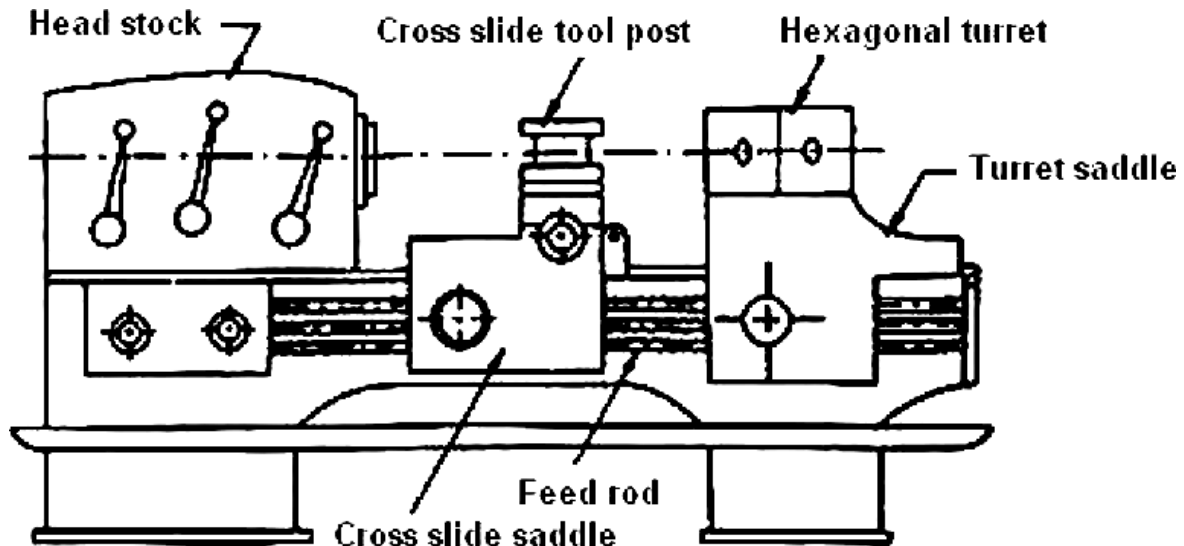

Fig. Basic configuration of a Turret lathe

Bed

The bed is a long box like casting provided with accurate guide ways upon which the carriage and turret saddle are mounted. The bed is designed to ensure strength, rigidity and permanency of alignment under heavy duty services.

Headstock

The head stock is a large casting located at the left hand end of the bed. The headstock of capstan and turret lathes may be of the following types:

- Step cone pulley driven headstock.
- Direct electric motor driven headstock.
- All geared headstock.
- Pre-optive or pre-selective headstock.

Step cone pulley driven headstock:

- ❖ This is the simplest type of headstock and is fitted with small capstan lathes where the lathe is engaged in machining small and almost constant diameter of workpieces.

Electric motor driven headstock:

- ❖ In this type of headstock the spindle of the machine and the armature shaft of the motor are one and the same. Any speed variation or reversal is effected by simply controlling the motor.

All geared headstock:

- ❖ On the larger lathes, the headstocks are geared and different mechanisms are employed for speed changing by actuating levers. The speed changing may be performed without stopping the machine.

Pre-optive or pre-selective headstock:

- ❖ It is an all geared headstock with provisions for rapid stopping, starting and speed changing for different operations by simply pushing a button or pulling a lever. The required speed for next operation is selected beforehand and the speed changing lever is placed at the selected position.

- ❖ After the first operation is complete, a button or a lever is simply actuated and the spindle starts rotating at the selected speed required for the second operation without stopping the machine. This novel mechanism is effect by the friction clutches.

Cross slide and saddle

In small capstan lathes, hand operated cross slide and saddle are used. They are clamped on the lathe bed at the required position. The larger capstan lathes and heavy duty turret lathes are equipped with usually two designs of carriage.

- Conventional type carriage.
- Side hung type carriage.

Conventional type carriage: This type of carriage bridges the gap between the front and rear bed ways and is equipped with four station type tool post at the front, and one rear tool post at the back of the cross slide. This is simple in construction.

Side hung type carriage: The side-hung type carriage is generally fitted with heavy duty turret lathes where the saddle rides on the top and bottom guide ways on the front of the lathe bed. The design facilitates swinging of larger diameter of workpieces without being interfered by the cross-slide.

Ram saddle: In a capstan lathe, the ram saddle bridges the gap between two bed ways, and the top face is accurately machined to provide bearing surface for the ram or auxiliary slide.

Turret saddle: In a turret lathe, the hexagonal turret is directly mounted on the top of the turret saddle and any movement of the turret is effected by the movement of the saddle. The movement of the turret may be effected by hand or power.

Turret: The turret is a hexagonal-shaped tool holder intended for holding six or more tools. Each face of the turret is accurately machined. Through the centre of each face accurately bored holes are provided for accommodating shanks of different tool holders.

Working principle of capstan and turret lathes

- The work pieces are held in collets or chucks. In turret lathes, large work pieces are held by means of jaw chucks.
- These chucks may be hydraulically or pneumatically operated. In a capstan lathe, bar stock is held in collet chucks.
- A bar feeding mechanism is used for automatic feeding of bar stock. At least eleven tools can be set at a time in turret and capstan lathes.
- Six tools are held on the turret faces, four tools in front square tool post and one parting off tool at the rear tool post. While machining, the turret head moves forward towards the job. After each operation, the turret head goes back.
- The turret head is indexed automatically and the next tool comes into machining position. The indexing is done by an indexing mechanism.
- The longitudinal movement of the turret corresponding to each of the turret position can be controlled independently.
- By holding different tools in the turret faces, the operations like drilling, boring, reaming, counter boring, turning and threading can be done on the component.
- Four tools held on the front tool post are used for different operations like necking, chamfering, form turning and knurling.
- The parting off tool in the rear tool post is used for cutting off the workpiece. The cross wise movements of the rear and front tool posts are controlled by pre-stops.

12. Explain the Bar feeding mechanisms (May 11 & Dec 11)

Bar feeding mechanisms

- ⇒ The capstan and turret lathes while working on bar work require some mechanism for bar feeding. The long bars which protrude out of the headstock spindle require to be fed through the spindle up to the bar stop after the first piece is completed and the collet chuck is opened.
- ⇒ In simple cases, the bar may be pushed by hand. But this process unnecessarily increases the total production time by stopping, setting, and starting the machine.
- ⇒ Therefore, various types of bar feeding mechanisms have been designed which push the bar forward immediately after the collet releases the work without stopping the machine, enabling the setting time to be reduced to the minimum.
- ⇒ The bar is passed through the bar chuck, spindle of the machine and then through the collet chuck. The bar chuck rotates in the sliding bracket body which is mounted on a long sliding bar.
- ⇒ The bar chucks grips the bar centrally by two set screws and rotates with the bar in the sliding bracket body. One end of the chain is connected to the pin fitted on the sliding bracket and the other end supports a weight.
- ⇒ The chain running over two fixed pulleys mounted on the sliding bar. The weight constantly exerts end thrust on the bar chuck while it revolves on the sliding bracket and forces the bar through the spindle at the moment the collet chuck is released.
- ⇒ Thus bar feeding may be accomplished without stopping the machine. In this way the bar is fed without stopping the machine.
- ⇒ After a number of such feedings, the bar chuck will approach the rear end of the head stock. Now the bar chuck is released from the bar and brought to the left extreme position. Then it is screwed on to the bar.

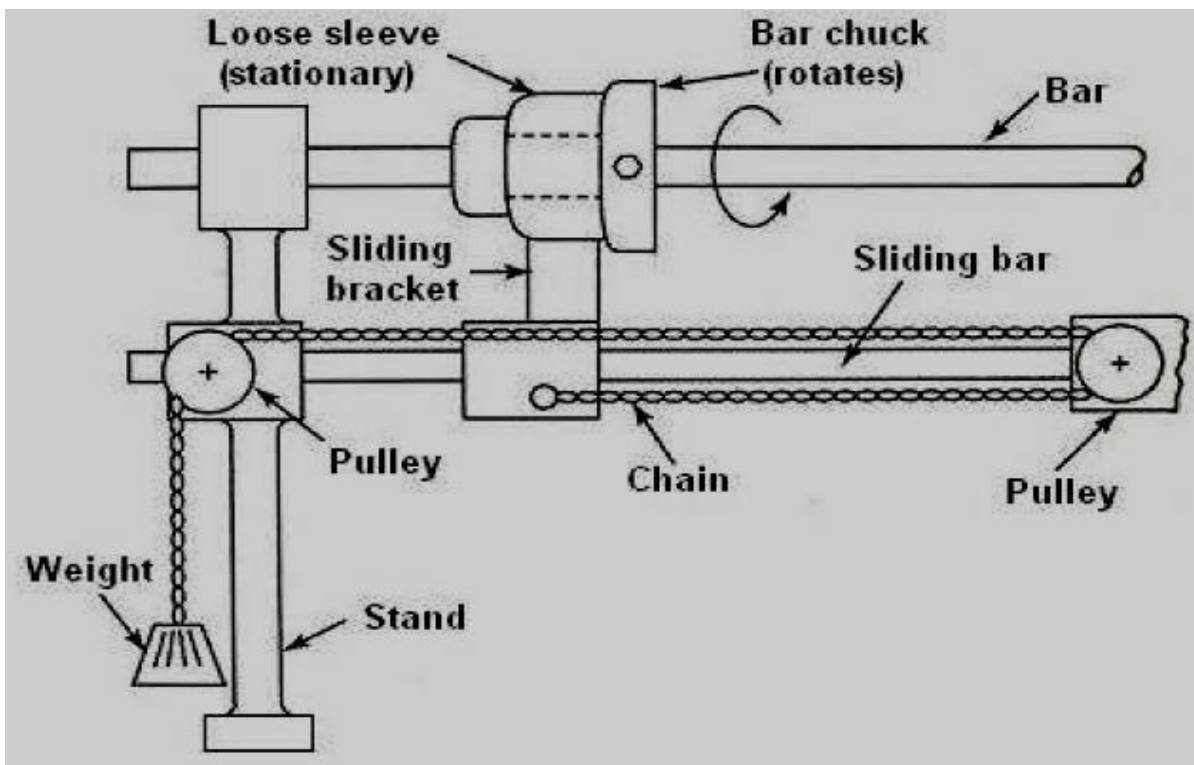

Fig. Bar feeding mechanism

12. Explain the various tool holding devices in lathe.

A variety of tool holding devices are used in turret and capstan lathes. These devices enable to hold different types of tools on the hexagonal turret faces and on the front and rear tool posts. The following are some of the most commonly used tool holding devices.

- I. Straight cutter holder
- II. Plain or adjustable angle cutter holder
- III. Multiple cutter holder
- IV. Multiple turning head or combination tool holder
- V. Slide tool holder
- VI. Knee tool holder
- VII. Roller steady box tool holder
- VIII. Recessing tool holder
- IX. Bar ending tool holder
- X. Work stop
- XI. Self-opening die holder
- XII. Collapsible tap
- XIII. Combination bar stop and centering tool
- XIV. Combination centering and facing tool.

13. Comparison of capstan and turret lathes (May 13)

S.No	Centre lathe	Capstan/turret lathe
1	It is a manually operated lathe	It is a semi-automatic lathe
2	It has only one tool post tool changing time is more	Front and rear tool posts are available. Tool changing time is less
3	It has tail stock	It has turret head instead of tail stock
4	Only one tool can be fitted in the tail stock	Six different tools can be fitted in the turret head.
5	Number of speeds is less	Number of speeds is more
6	Tool changing time is more	Tool changing time is less
7	The machine should be stopped for changing tool	Tool can be changed without stopping the machine
8	It is not suitable for mass production	It is suitable for mass production
9	No feed stops to control the tool	The tools are controlled by feed stops
10	The tool is centered manually after	the tool is centered automatically
11	Only one operation is done at a time	More than one operation can be done at a time

14. Explain about the specifications of capstan and turret lathes.

The main sizes to be specified in any capstan and turret lathes are:

- Maximum diameter of the workpiece that can be machined.
- Swing over cross slide.
- Swing over bed.

E.g. 100-200-250 refers to the maximum diameter that can be machined by using this size of lathe is 100 mm, the size of swing over cross slide is 200 mm and the size of swing over bed is 250 mm.

- In addition to the above sizes, the following details are also needed to specify the full description about the machine:
 - Power of the main drive motor.
 - Range of spindle speeds.
 - Range of feeds for the carriage.
 - Range of feeds for the turret or saddle.
 - Total weight of the machine.
 - Floor space required.

1. Explain automatic lathes and its advantage? (Nov 2004)

AUTOMATIC LATHES

- ❖ Highly automated machine tools especially of the lathe family are ordinarily classified as semi-automatics and automatics. Automatics as their name implies are machine tools with a fully automatic work cycle.
- ❖ Semi-automatics are machine tools in which the actual machining operations are performed automatically in the same manner as on automatics. In this case however, the operator loads the blank into the machine, starts the machine, checks the work size and removes the completed piece by hand.

Work holding devices used in automatic lathes:

- ❖ Automation is incorporated in machine tool systems to enable faster and consistently accurate processing operations for increasing productivity and reducing manufacturing cost in batch and mass production.
- ❖ Therefore, in semiautomatic and automatic machine tools mounting and feeding of the work piece or blank is done much faster but properly.
- ❖ Mostly collet chucks are used for holding the work pieces. Collet chucks inherently work at high speed with accurate location and strong grip.
- ❖ The chucks are actuated manually or semi automatically in semi-automatic lathes and automatically in automatic lathes.

SEMI AUTOMATICS:

Semi-automatics are employed for machining work from separate blanks. The operator loads and clamps the blanks, starts the machine and unloads the finished work. The characteristic features of semi-automatic lathes are:

- Some major auxiliary motions and handling operations like bar feeding, speed change, tool change etc. are done quickly and consistently with lesser human involvement.
- The operators need lesser skill and putting lesser effort and attention.
- Suitable for batch or small lot production.
- Costlier than centre lathes of same capacity.

CLASSIFICATION OF SEMIAUTOMATICS

2. Explain in detail of Single spindle semi-automatics. (April 2004 & May 2012)

Explain any two types of work holding devices used on a semi-automatic lathe. (April/May 2015)

Single spindle semi-automatics

Centre type:

- In this type, the workpiece is held between centres, for which a head stock and a tail stock are mounted on the bed of the machine. Usually, external stepped or formed surfaces are machined on this machine.
- The work is machined by two groups of cutting tools. The front tool slide holds the cutting tools which require a longitudinal feed motion to turn the steps of a shaft, while the rear tool slide carries the tools that require a transverse feed motion to perform operations such as facing, shouldering, necking, chamfering etc.

Chucking type:

- In this type, the workpiece is held in a chuck. Such a machine may be equipped with various tool slide arrangements.
- In addition to longitudinal and transverse feed tool slides, these machines may also be equipped with a central end working tool slide or a turret if internal surfaces are also to be machined in addition to the external surfaces.

SINGLE SPINDLE AUTOMATS:

- These machines have only one spindle. So, one component can be machined at a time. These are modified form of turret lathe.
- These machines have maximum of 4 cross slides in addition to a 6 stations or 8 station turrets. These cross slides are operated by disc cams which draws the power from the main spindle through cycle time change gears. The single spindle automats are of the following types:

3. Explain in detail of Multi spindle semi-automatics. (April 2004 & May 2012)

Describe various types of multi spindle automats. (April/May 2015)

Multi spindle semi-automatics

The machine may also be built in two designs:

- Centre type.
- Chucking type.

These multi spindle semi-automatics are classified as:

- Parallel action or single station type.
- Progressive action or multi station type.

AUTOMATS

These are machine tools in which the components are machined automatically. The working cycle is fully automatic that is repeated to produce identical parts without participation of the operator. All the working and idle operations are performed in a definite sequence by the control system adopted in the automats which is set up to suit a given work.

Classification of Automats

The automats can be classified as follows:

According to the type of work materials used:

- Bar stock machine.
- Chucking machine.

According to the number of spindles:

- Single spindle machine.
- Multi spindle machine.

According to the position of spindles:

- Horizontal spindle type.
- Vertical spindle type.

According to the use:

- General purpose machine.
- Single purpose machine.

According to the feed control:

- Single cam shaft rotating at constant speed.
- Single cam shaft with two speeds.
- Two cam shafts.

Advantages of automats over conventional lathes:

- Mass production of identical parts.
- High accuracy is maintained.
- Time of production is minimized.
- Less floor space is required.
- Unskilled labor is enough. It minimizes the labor cost.
- Constant flow of production.
- One operator can be utilized to operate more than one machine.
- The bar stock is fed automatically.
- Scrap loss is reduced by eliminating operator error.

4. Explain single spindle automatic cutting off machine and its working.

SINGLE SPINDLE AUTOMATIC CUTTING OFF MACHINE:

- This machine produces large quantities of workpieces of smaller diameter and shorter lengths. Components with simple form are produced in this machine by means of cross sliding tools.

Construction:

- This machine is simple in design. The head stock with the spindle is mounted on the bed.

- Two cross slides are located on the bed at the front end of the spindle.
- The front cross slides are used for turning and forming operations. The rear tool slide is used for facing, chamfering, recessing, under cutting and cutting off operations. Cams on a camshaft actuate the movements of the cross slides through a system of levers.

Working principle:

- ❖ The required length of work piece (stock) is fed out with a cam mechanism, up to the stock stop which is automatically advanced in line with the spindle axis, at the end of each cycle.
- ❖ The stock is held in the collect chuck of the rotating spindle. The machining is done by tools held in cross slides operating only in the crosswise direction.

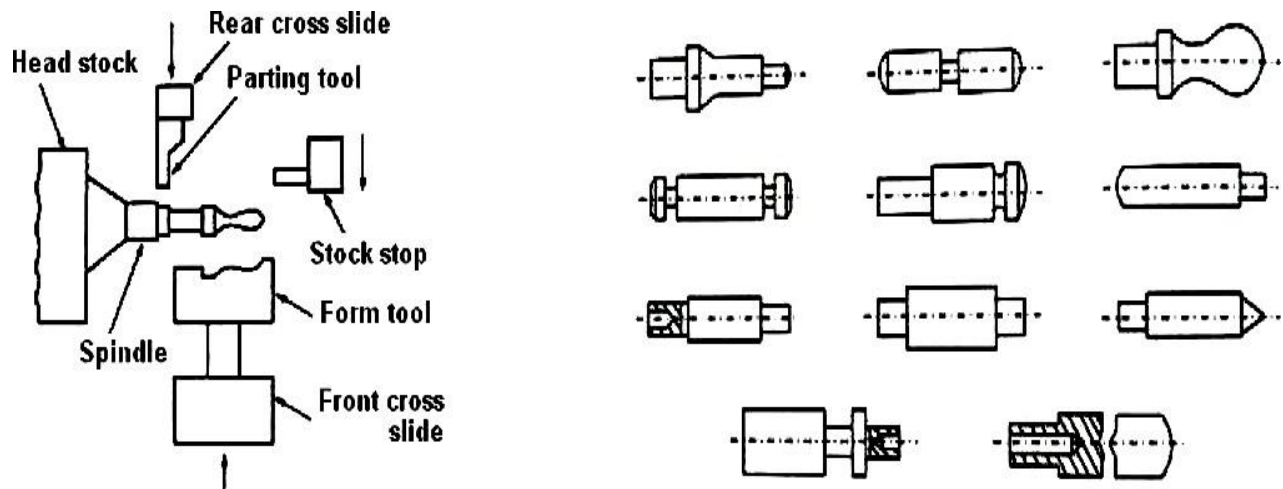

Fig. Arrangement of tool slide Fig. Simple parts produced on cutting off machine

- ❖ The form tool held in the front tool slide produces the required shape of the component. The parting off tool in the rear tool slide is used to cut off the component after machining.
- ❖ Special attachments can be employed if holes or threads are required on the simple parts.
- ❖ This machine has a single cam shaft which controls the working and idle motions of the tools. The cam shaft runs at constant speed. Therefore working motions and idle motions takes place at the same speed. Hence the cycle time is more.

5. Explain Swiss type automatic screw machine. (Nov 2003, Nov'05, 08, May'10, 11)

SWISS TYPE AUTOMATIC SCREW MACHINE

- ❖ This machine was designed and developed in Switzerland. So it is often called as Swiss auto lathe. This machine is also known as „Sliding head screw machine“, or „Movable headstock machine“, because the head stock is movable and the tools are fixed. This machine is used for machining long accurate parts of small diameter (2 mm to 25 mm).

Construction:

This machine has the following parts:

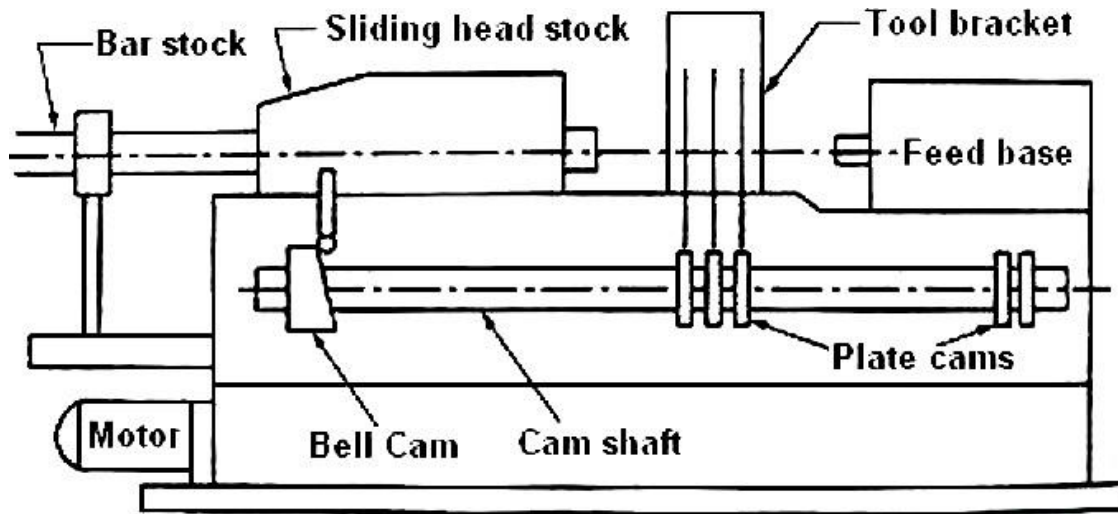

Fig. Swiss type automatic screw machine

Sliding Head Stock: This head stock has a collet. The bar stock is held in this collet. The headstock slides along the guide ways of the bed. A bell cam connected to the cam shaft controls this sliding motion.

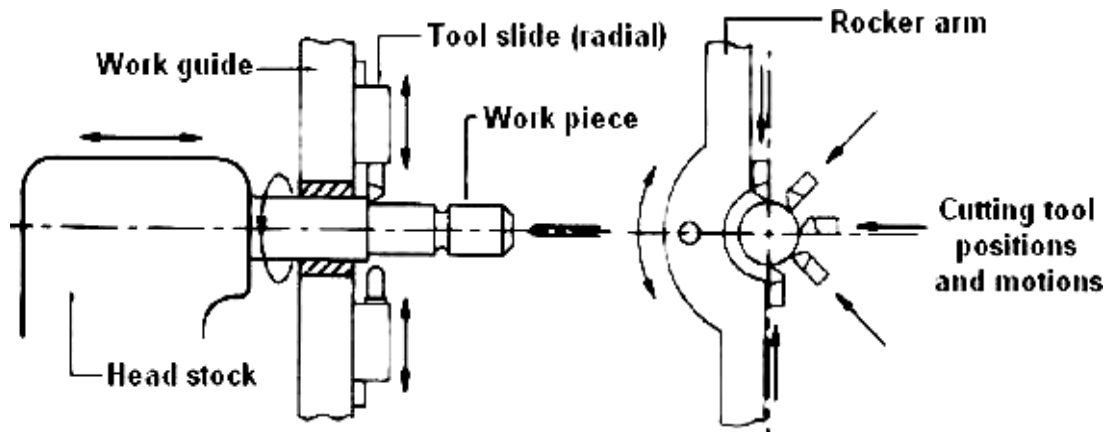

Fig. Working principle of the Swiss type automatic screw machine

Tool Bracket:

- The tool bracket is mounted on the bed way near the head stock. The tool bracket supports 4 or 5 toll slides. It also has a bush for supporting and guiding the bar stock.
- Two slides are positioned horizontally (front and rear) on which the turning tools are normally clamped. The other slides are arranged above these slides.
- These slides can move radially. All the slides can move back and forth. These slides are actuated independently by sets or rocker arms and plate cams. Plate cams are fitted to the cam shaft.

Feed Base:

- The feed base is a special attachment mounted at the right hand side of the bed. This can move along the bed.
- Using this attachment, operations like drilling, boring, thread cutting with taps or dies etc., are done. The movement of the feed base is controlled by the plate cam fitted to the cam shaft.

Cam Shaft:

- The cam shaft is mounted at the front of the machine. It has a bell cam at the left end. This controls the sliding movement of the head stock.
- Plate cams fitted at the centre of the shaft controls the movement of the tool slides. Plate cam at the right end of the cam shaft controls the movement of the feed base.

Working principle

- The stock is held by a rotating collet in the head stock and all longitudinal feeds are obtained by a cam which moves the head stock as a unit.
- Most diameters turning are done by two horizontal tool slides while the other three slides are used principally for such operations as knurling, chamfering, recessing and cutting off.
- The tools are controlled and positioned by cams that bring the tools in as needed to turn, face, form, and cut off the workpiece from the bar as it emerges from the bushing.
- The cutting action is confined close to the support bushing reducing the overhang to a minimum.
- As a result, the work can be machined to very close limits. All tools can work at a time.
- After the work piece is machined, the head stock slides back to the original position. One revolution of the cam shaft produces one component.
- A wide variety of formed surfaces may be obtained on the workpiece by synchronized alternating or simultaneous travel of the headstock (longitudinal feed) and the cross slide (approach to the depth of cut).
- The bar stock used in these machines has to be highly accurate and is first ground on centreless grinding machines to ensure high accuracy.

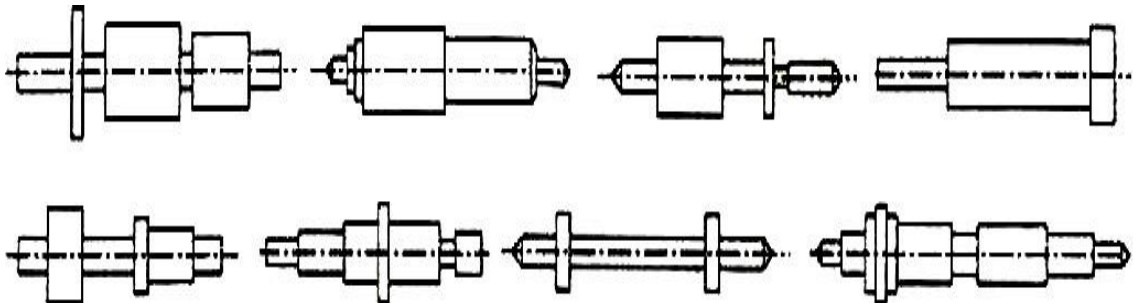

Fig. Simple parts produced on Swiss auto lathe

Advantages

- It is used to precision turning of small parts.
- Wide range of speeds is available.
- It is rigid in construction.
- Micrometer tool setting is possible.
- Interchange ability of cams is possible.
- Tolerance of 0.005 mm to 0.0125 mm is obtained.

SINGLE SPINDLE AUTOMATIC SCREW TYPE MACHINE

6. Explain single spindle automatic screw type machine with neat sketches. (April/May 2008)
(May'13, April/May 2014)

- ❖ This is essentially wholly automatic bar type turret lathe.

- ❖ This is very similar to capstan and turret lathes with reference to tool layout, but all the tool movements are cam controlled, such that full automation in manufacturing is achieved.
- ❖ This is designed for machining complex external and internal surfaces on parts made of bar stock or of separate blanks.

Construction

- ❖ Up to ten different cutting tools may be employed at a time in this machine. The tools are fixed in indexing turret and in cross-slides.
- ❖ The turret carries six tools. Two cross-slides (front and rear) are employed for cross-feeding tools. A vertical slide for parting off operation may also be provided.
- ❖ It is installed above the work spindle. The stationary headstock, mounted on the left end of the bed, houses the spindle which rotates in either direction.

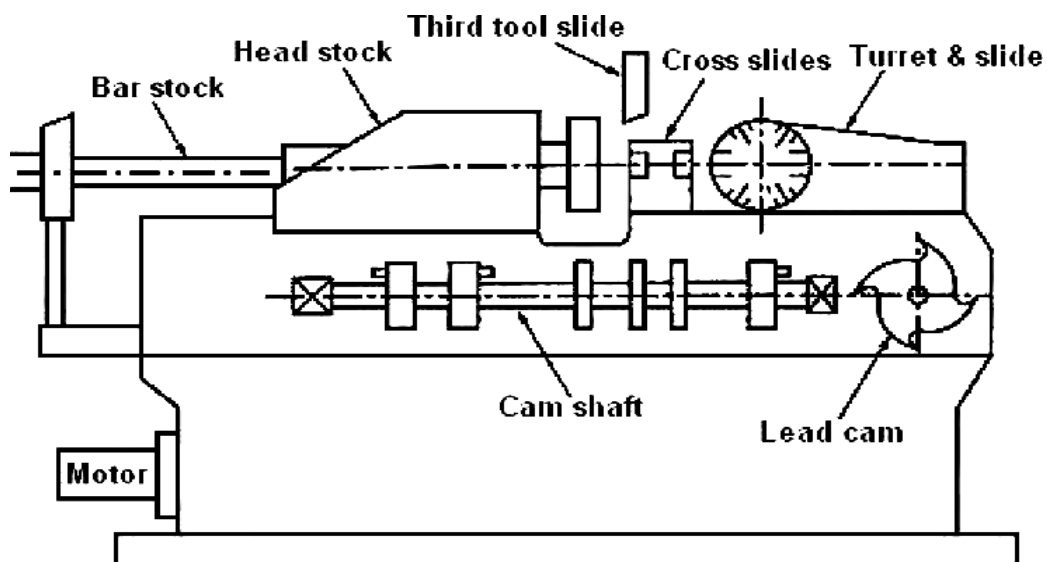

Fig. Single spindle automatic screw cutting machine

Working principle

- The bar stock is held in a collet chuck and advanced by a feed finger after each piece is finished and cut off.
- All movements of the machine units are actuated by cams mounted on the camshaft. The bar stock is pushed through stock tube in a bracket and its leading end is clamped in rotating spindle by means of a collet chuck.
- The bar is then fed out for the next part by stock feeding mechanism. Longitudinal turning and machining of the central hole are performed by tools mounted on turret slide. The cut off and form tools are mounted on the cross-slides.
- At the end of each cut, turret slide is withdrawn automatically and indexed to bring the next tool into position.
- One revolution of camshaft produces one component. It is used for producing small jobs, screws, stepped pins, taper pins, bolts, etc.

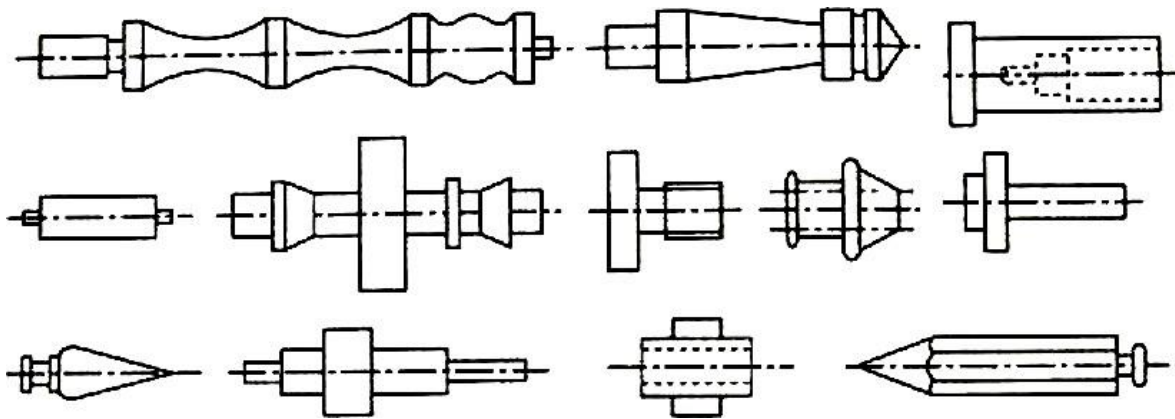

Fig. Parts produced on single spindle automatic screw cutting machine

19. Describe various types of multi spindle automats (May-Jun-'16)

MULTI SPINDLE AUTOMATS:

- ❖ The multi spindle automats are the fastest type of production machines and are made in a variety of models with 2, 4, 5, 6 or 8 spindles.
- ❖ Each of the spindles is provided with its own set of tools for operation. As a result, more than one work piece can be machined simultaneously in these machines.
- ❖ In contrast to the single spindle automat, where one turret face at a time is working on one spindle, the multi spindle automat has all turret faces working on all spindles at the same time.
- ❖ The production rate of a multi spindle automat, however, is less than that of the corresponding number of single spindle automats. E.g. the production rate of a 4 spindle automat is not four times but only 2½ to 3 times more than that of a single spindle automat.

Classification of multi spindle automats:

The multi spindle automats can be classified as follows:

According to the type of stock used:

- ✓ Bar stock machine.
- ✓ Chucking type machine.

According to the position of spindles:

- ✓ Horizontal spindle type.
- ✓ Vertical spindle type.

According to the principle of operation:

- ✓ Parallel action type.
- ✓ Progressive action type.

PARALLEL ACTION MULTI SPINDLE AUTOMAT:

- ❖ These machines are usually automatic cutting off bar type machines. This is also called as „multiple-flow“ machine.

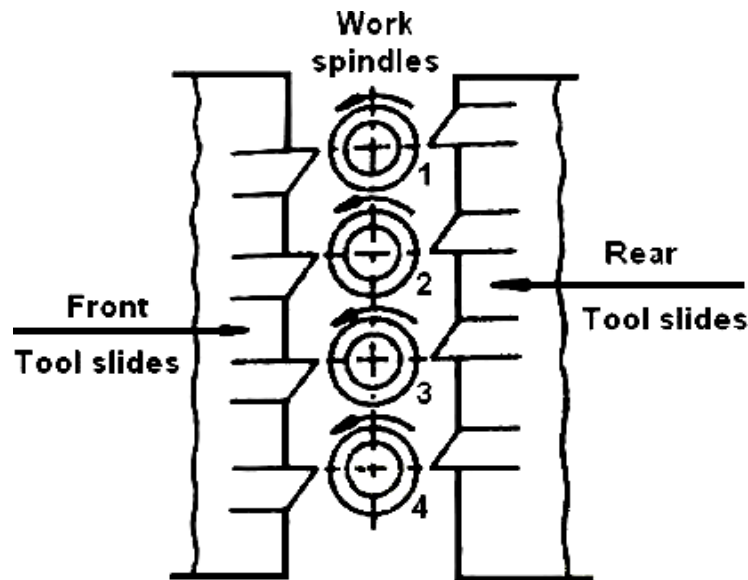

Fig. Parallel action multi spindle automat

- ❖ In this machine, the same operation is performed on each spindle and a workpiece is finished in each spindle in one working cycle.
- ❖ The rate of production is very high, but the machine can be employed to machine simple parts only since all the machining processes are done at one position.
- ❖ They are used to perform the same work as single spindle automatic cutting off machines. Centering or a single drilling operation can also be performed on certain models. The machine consists of a frame with a head stock.
- ❖ The horizontal work spindles which are arranged in a line, one above the other, are housed in this headstock. Cross slides are located at the right and left hand sides of the spindles and carry the cross feeding tools.
- ❖ All the working and the auxiliary motions of the machine units are obtained from the cam mounted on the cam shaft.

PROGRESSIVE ACTION MULTI SPINDLE AUTOMAT

In this machine the blanks clamped in each spindle are machined progressively in station after station.

Construction

- ❖ The headstock is mounted at the left end of the base of the machine. It contains a spindle carrier which periodically indexes through a definite angle (3600 divided by the number of spindles) about a horizontal axis through the centre of the machine at each tool retraction.

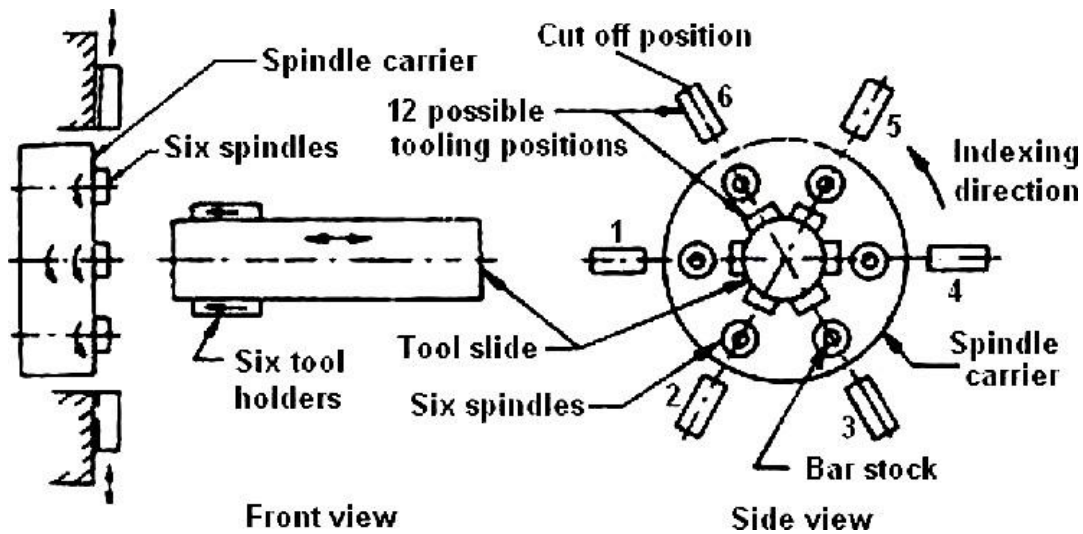

Fig. Six-spindle progressive action automat

- ❖ The main tool slide (end tool slide), which accommodates tooling for all of the spindles, travels on the spindle carrier stem. The number of tool slides or faces is equal to the number of spindles.
- ❖ The working spindles are mounted in this spindle carrier. The working spindles carry the collets on which the work pieces are held.
- ❖ The bar stock is fed to the working spindle from the rear. Cross slides which carry tools for operations such as cut off, turning, facing, forming, chamfering etc. are mounted in a frame above the face of the spindle carrier.
- ❖ These cross slides travel radially inward for cutting operation. The number of cross slides is equal to the number of spindles. The feed of each tool, both cross slide tools and end slide tools, is controlled by its own individual cam.

Working principle

- The spindle carrier indexes on its own axis by 600 ($3600/6$) at each tool retraction. As the spindle carrier indexes, it carries the work from station to station, where various tools operate on it.
- The stock moves around the circle in counter clockwise direction and comes to the station number 6 for cutting off. A finished component is obtained for one full revolution of the spindle carrier.

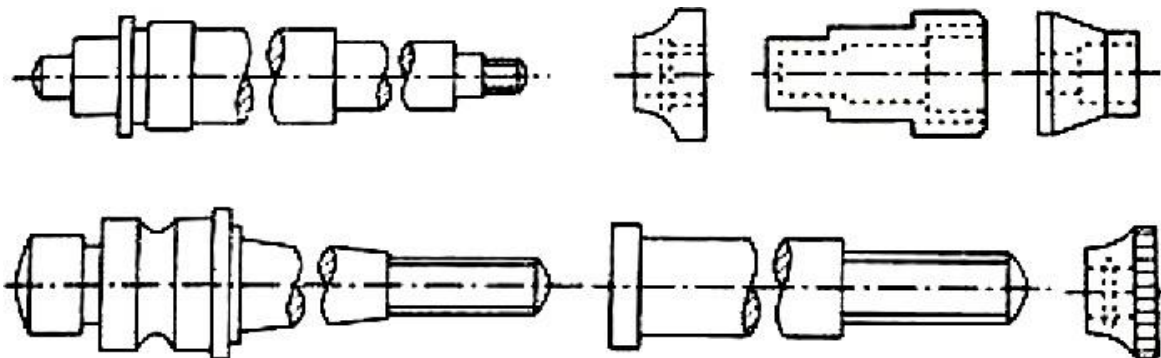

Fig. Parts produced on multi spindle automatic lathe

7. Comparison of parallel action and progressive action multi spindle automatic lathe. (June 2006& Dec 2006 & May 2014,Nov 2016)

Sl.No	Parallel Action Machine	Progressive Action Machine
1	Same operation is done on all jobs in all the spindles	Different operation are done on jobs at each station one after another
2	In one cycle, the number of components produced simultaneously is equal to the number of spindles	It is not so, (i.e) the number of components produced in one cycle is not equal to the number of spindles. for every indexing of component (spindle) one component is produced
3	Rate of production is very high	Rate of production is moderate
4	If anything goes wrong in one station, the production in that particular station only is affected	If anything goes wrong in one station, the production is completely affected in all the stations.

UNIT III
Shaper Milling and Gear Cutting Machines
PART A

1. What is shaper?

The machine which is having a reciprocating type of machine tool with single point cutting tool used to produce flat surface called shaper.

2. List any four important parts of a shaper.

- i. Table
- ii. Tool head
- iii. Ram
- iv. Cross-rail

3. Define cutting ratio in a shaper.

The ratio between cutting stroke time to return stroke time,

$$m = \frac{\text{cutting stroke time}}{\text{return stroke time}}$$

4. List any two types of quick return mechanisms.

- (i) Hydraulic drive mechanism
- (ii) Crank and slotted lever mechanism

5. Write the Classification of the shaper.

Classification of the shaper according to the reciprocating of ram:

- i. Crank type
- ii. Hydraulic type
- iii. Geared type.

Classification of the shaper according to the travel and position of the ram:

- Horizontal type,
- Vertical type
- Traveling head type.

Classification of the shaper according to the design of table:

- Standard type
- Universal type.

Classification of the shaper according to the type of cutting stroke:

- Push type
- Draw type

6. How are shaping machines specified.(May/June 2012) (May /June 2013)

Generally a shaper may be specified by its maximum length of stroke.

The other specifications are:

1. Type of drive (Mechanical or hydraulic)
2. Power of motor-3 HP
3. Speed and feed available.
4. Ratio of cutting stroke time and return stroke time-2:1
5. Floor area required – 1981 mm x 1067 mm.
6. Net weight .Approximately-1750 kg.
7. Maximum vertical travel of table – 475 mm
8. Maximum horizontal travel of table-450 mm.

9. Size of side table-473 mm x 330 mm.

10. Maximum vertical travel of tool slide-150 mm.

7. Mention the differences between shaper and planer. (Apr/May 2011)

S.No	SHAPER	PLANER
1.	Cutting stroke is slower than inactive /idle stroke.	Cutting stroke is slower here also.
2.	Shaper machine is use for small workings.	Meant for much larger jobs. Jobs as large as 6 meter wide and twice as long can be machined..
3.	A single cutting tool is used for machining at a time.	Two or extra cutting tools are used for machining at a time.
4.	The work is held stationary and the tool on the ram is moved back and forth across the work.	The tool is stationary and the work piece on the table travels back and forth under the tool.
5.	Stroke length is small.	Stroke length is considerably bigger than that of a shaper.

8. State the differences between a vertical shaper and slotter. (Nov/Dec 2008)

A vertical shaper and a slotter are almost similar to each other as regards to their construction, operation, and use. The only difference being in the case of a vertical shaper, the ram holding the tool may also reciprocate at an angle to the horizontal table in addition to the vertical stroke.

9. Mention the operations performed by a shaper.

1. Machining horizontal surface.
2. Machining vertical surface.
3. Machining angular surface.
4. Machining irregular surface.

10. Compare hydraulic shaper and mechanical shaper.

S.No	Hydraulic shaper	Mechanical shaper
1.	The reciprocating movement is obtained by using cylinders and pistons in a hydraulic system.	The reciprocating movement is obtained by using crank mechanism (Bull gear) or geared mechanism (rack and pinion arrangement).
2.	Hydraulic power namely oil is used.	Power is obtained either from an individual motor or from an overhead line shaft if it is a belt driven shaper.
3.	Cutting speed and force of the ram drive are constant from the very beginning to the end of the cut.	Cutting speed and force of the ram drive is not constant or uniform.
4.	It offers great flexibility of speed and feed control.	No great flexibility of speed and feed control.

11. List the different parts involved in the shaper.

The main parts of horizontal shaper are as below:

1. Ram
2. Table
3. Clapper box
4. Tool head
5. Column
6. Cross Rail
7. Stroke Adjustment
8. Table supports
9. Base

12. List the parts in tool head.

The parts in tool head:

- Swivel base
- Vertical slide
- Apron
- Tool post

13. List the parts in apron.

- Clapper box
- Clapper block
- Tool post

14. What are the different types of mechanism used in shaper?

- a. Crank and slotted Mechanism
- b. Whit worth mechanism
- c. Hydraulic shaper mechanism

15. List the two blocks used in the Crank and slotted Mechanism.

- a. Bull gear sliding block
- b. Rocker arm sliding block.

16. Define slot milling.

- It is also a type of milling operation, also called as slot milling operation. In this case width of the cutter is less than the width of work piece. It is used to make slot in the work piece.
- Thin slots can be made by using very thin milling cutters.
- The work piece can be cut into two pieces by making a very thin slot throughout the depth of work piece. Cutting the work piece this way be slot milling is called saw milling.

17. How are work pieces held in a shaper? (April /May 2010)

The work may be supported on the table by the following methods depending on the nature of the work piece.

1. Clamped in a vise
2. Clamped on the table
3. Clamped to the angle plate
4. Clamped on a V- block
5. Held between shaper index centre

18. What are the devices used to hold the work on the shaper table?

- a. T bolt and clamps
- b. Stop pins

c. Stop pins and toe dogs

c. Strip and stop pins

19. What is planer?

A planer is a type of metalworking machine tool that uses linear relative motion between the work piece and a single-point cutting tool to machine a linear tool path. Its cut is analogous to that of a lathe, except that it is (archetypally) linear instead of helical..

20. Define feed and depth of cut in a shaper.

Feed(s) is the relative movement of the tool or work in a direction perpendicular to the axis of reciprocation of the ram per double stroke and is expressed in mm. The feed is always given at the end of return stroke when the tool is not cutting the metal. The selection of feed is dependent upon the kind of metal, type of job, etc.

Depth of cut:

Depth of cut (t) is the thickness of metal that is removed in one cut. It is the perpendicular distance measured between machined surface and non-machined surface of the work piece.

21. What is the difference between shaper and slotter?

S.No	SHAPER	SLOTTER
1	The work is stationary and the tool on the ram is moved back forth(horizontal axis) across the work	The work is held stationary and the tool on the ram is moved up and down (vertical axis) across the work.
2	Used for shaping much smaller jobs.	It is used for making slots in smaller jobs.
3	Is a light machine	Slotting is light machine
4	Can employ light cuts and finer feed	Can employ light cuts and finer feed.
5	Uses one cutting tool at a time	Slotter uses one cutting tool at a time
6	Driven using quick- return link Mechanism	The rams are either crank-driven or Hydraulically driven
7	It is less rigid and less robust	It is less rigid and less robust

22. What is the difference between planner and slotter?

S.No	PLANER	SLOTTER
1	It can use heavier use and coarse feed	Its can use light cuts and improved feed
2	Some tools can cut at the same time	Shaper uses single cutting tool at a time
3	It is heavy weight machine	It is light machine
4	Drive a planner table is too by gears or by hydraulic means	The ram are also crank driven or hydraulically drive.
5	Job as big like six meter wide and twice as long can be machined	It use for make slots in small jobs.

23. What is meant my drilling?

Drilling is the process of producing hole on the workpiece by using a rotating cutter called drill.

24. List the types of drilling machines.

Types of drilling machines:

1. Portable drilling machine.
2. Sensitive drilling machine.
 - a) Bench mounting
 - b) Floor mounting
3. Upright drilling machine.
 - a) Round column section
 - b) Box column section

4. Radial drilling machine
 - a) Plain
 - b) Semi-universal
 - c) Universal
5. Gang drilling machine.
6. Multiple spindle drilling machines.
7. Automatic drilling machine.
8. Deep hole drilling machine.
 - a) Vertical
 - b) Horizontal

25. List the parts involved in the upright drilling machine.

1. Base
2. Column
3. Table
4. Head
5. Spindle
6. quill
7. Drill head assembly.

26. List the parts involved in the radial drilling machine.

1. Base
2. Column
3. Radial arm
4. Drill head

27. What are the different operations performed in drilling machine?

1. Drilling
2. Reaming
3. Boring
4. Counter boring
5. Counter sinking
6. Spot facing
7. Tapping
8. Lapping
9. Grinding.

28. Define the cutting speed, feed and machining time for drilling. (Nov/Dec 2010)

cutting speed

It is the peripheral speed of a point on the surface of the drill in contact with the work piece. The cutting speed (v) may be calculated as:

$$V = \frac{\pi \times d \times n}{1000} \text{ m/min}$$

Where, d is the diameter of the drill in mm

N is the r.p.m. of the drill spindle.

Feed:

The feed of a drill is the distance the drill moves into the work at each revolution of the spindle. It is expressed in millimeter or may also be expressed as feed per minute. The feed (S_m) per minute may be calculated as:

$$S_m = S_r \times n$$

Where S_m = Feed per minute in mm.

S_r = Feed per revolution in mm.

N = r.p.m. of the drill.

Machining time:

Time taken to complete the machining process without considering the idle time of machine is called machining time. The machining time can be calculated by using the following relation

$$\text{Machining time, } T = \frac{\text{length of the tool travel in mm}}{\text{feed in } \frac{\text{mm}}{\text{rev}} \times \text{rpm of the spindle}}$$

Where, n = r.p.m. of the drill

s_r = Feed per revolution of the drill in mm/rev

L = Length of travel of the drill in mm

And T = Machining time in min.

$$L = l_1 + l_2 + l_3 + l_4$$

Where l_1 = length of the work piece

l_2 = approach of the drill

l_3 = length of the drill point

l_4 = over travel

29. What do you know about straight fluted drill and fluted drill? (Nov/Dec 2009)

Straight Fluted drill:

The reamer with helical flutes provides a smooth shear cutting action and it provides a better surface finish. The pitch of the flutes is made uneven to reduce vibration.

Fluted drill:

Most drill bits for drilling wood, metal or masonry incorporate some type of flute in the design. The flute is a deep groove that typically twists around the bit, giving the waste material a path out of the hole.

30. What is heel, Flank and Lip in a drill?

Heel:

The edge is formed by the intersection of the flute surface and body clearance in a drill .

Flank:

The surface on a drill point which extends behind the lip to the following flute.

Lip (cutting edge):

The edge formed by the intersection of the flank and face. The requirements of the drill lip are

1. Both lips should be at the same angle of inclination with the drill axis, 59° for general work.
2. Both should be of equal length.
3. Both lips should be provided with the correct clearance.

31. What are the advantages of using diamond drill bit?

- 1 - Cuts through Tougher Materials
- 2 - Speed
- 3 - Metal Bonded Bits
- 4 - Prevents Chips and Cracks
- 5 - Minimal Noise.

32. What is reaming?

Reaming is the process of sizing and finishing the existing drilled hole. The tool used for reaming is known as reamer.

33. What is tapping?

Tapping as shown in the figure is the operation of cutting internal threads by means of a cutting tool called a tap. A tap may be considered as a bolt with accurate threads cut on it. The threads act as cutting edges which are hardened and ground. When the tap is screwed into the hole it removes metal and cuts internal threads which will fit into external threads of the same size.

34. Write the differences between drilling and tapping. (Nov/Dec 2008)

Drilling:

Drilling is the process of producing hole on the workpiece by using a rotating cutter called drill. The different shapes of holes can be made.

Tapping:

Tapping is the process used for making internal threads in a machine component by a tool called tap. Internal thread can be cut in existing drilled holes.

35. What are the differences between drilling and reaming? (Apr/May 2011)

Drilling:

This is an operation of creating a circular hole by removing a volume of metal from a job by rotating a cutting tool called drill. Drilling removes solid metal to create a round hole.

Reaming:

Drilled hole is constantly bigger than diameter of drill. While a round hole by straight with flat walls is required reaming is done. It is a process of sizing, aligning and smooth a drilled hole through use of a reamer.

36. What is boring?

Boring is a process of enlarge and locating previously drilled holes with a single point cutting tool.

37. What are applications of boring?

The boring machine is designed for machining large and heavy workpiece in mass production work of engine frame, cylinder, machine housing.

38. What is a milling machine?

Milling is the process of removing metal by feeding the work past against a rotating multipoint cutter.

39. What are the types of milling machines?

1. Column and knee type milling machine
 - a. Hand milling machine
 - b. Plain milling machine
 - c. Universal milling machine
 - d. Omniversal milling machine
 - e. Vertical milling machine
2. Manufacturing of fixed bed type.
 - a. Simplex milling machine
 - b. Duplex milling machine
 - c. Triplex milling machine
3. Planer type
4. Special type.
 - a. Rotary table milling machine
 - b. Drum milling machine

40. What is the difference between a plain milling machine and an universal milling machine? (Nov/Dec 2012)

S.No	Plain milling	Universal milling
1.	Plain milling is provided with three table movements: longitudinal, cross and vertical.	A universal milling machine has a fourth movement of the table in addition to the three movements in plain milling machine.
2.	Plain milling machine is not provided with auxiliary's equipment.	Universal milling machine is provided with auxiliaries such as dividing head equipment, vertical milling attachment, rotary table, etc.
3.	Plain milling machine is more rigid and heavier in construction.	Universal milling machine is not that rigid and is lighter.
4.	Plain milling is adapted for manufacturing operations.	Universal milling machine is intended more for tool room work and for special machining operations.

41. What are the special attachments made in the universal milling machine?

1. Dividing head or Index head
2. Vertical milling attachment
3. Rotary attachment
4. Slotting attachment

42. What is vertical milling machine?

In vertical milling machine the spindle is mounted vertical or perpendicular to the table. The machine may be plain or universal type and has all the movements of the table for proper setting and feeding the work.

43. What are the parts used in the column and knee type milling machine?

1. Base
2. Column
3. Knee
4. Table
5. over hanging arm
6. Front brace
7. Arbor

44. State the differences between up milling and down milling. (Nov/Dec 2013) (Apr/May 2010) (Apr/May 2011)

S.No	Event of operation	Up Milling	Down Milling
i.	Direction of travel	The cutter rotates against the direction of travel of workpiece	The cutter rotates in the same direction of travel of workpiece
ii.	Chip thickness	Minimum at the beginning of cut reaches maximum when the cut terminates	Maximum at the beginning reaches minimum at terminates
iii.	Cutting forces	It increases from zero to maximum per tooth	It decreases from zero to maximum per tooth

45. What are the various milling operations?

Different operations can be performing on milling machine:

1. Face Milling Operation
2. Straddle Milling Operation
3. Side Milling Operation
4. Plain Milling Operation

- | | |
|-------------------------------|------------------------------|
| 5. Angular Milling Operation | 6. Gang Milling Operation |
| 7. Profile Milling Operation | 8. Form Milling Operation |
| 9. End Milling Operation | 10. Slot Milling Operation |
| 11. Gear Cutting Operation | 12. Saw Milling Operation |
| 13. Cam Milling Operation | 14. Thread Milling Operation |
| 15. Helical Milling Operation | |

46. What is meant by up milling and down milling? (Nov/Dec 2008)

In up milling process, the cutter rotates opposite to the direction of feed of the workpiece whereas in down milling, the cutting rotates in the same direction of travel of the workpiece.

47. What is the difference between face milling and end milling?

Face milling:

Face milling makes use of a cutter that machines a surface at right angles to the spindle axis and parallel to the face of the tool.

End Milling:

End milling is the operation of machining flat surfaces, either horizontal, vertical, or at an angle, using an end mill as a cutter. These cutters have teeth on the end face as well as on the periphery.

48. How do you classify milling cutters? (Nov/Dec 2009, April/May 2010)

There are many different types of standard milling cutters. They are classified as :

1. Plain milling cutter
 - A) Light duty plain milling cutter
 - b) Heavy duty plain milling cutter
 - c) Helical plain milling cutter
2. Side milling cutter
 - a) Plain Side milling cutter
 - b) Staggered teeth Side milling cutter
 - c) Half Side milling cutter
 - d) Interlocking Side milling cutter
3. Metal slitting saw
 - a) Plain metal slitting saw
 - b) Staggered teeth metal slitting saw
4. Angle milling cutter
 - a) Single Angle milling cutter
 - b) Double Angle milling cutter
5. End mill
 - a) Taper shank end mill
 - b) Straight shank end mill
 - c) Shell end mill

49. What is a shell mill? (Nov/Dec 2007).

The shell mill is a large type of face or end mill that mounts onto an arbor, rather than having an integral shank. Typically, there is a hollow or recess in the centre of the shell mill for mounting hardware onto a separate arbor.

50. What are the various types of end mills used in milling? (AU April / May 2010)

1. Taper shank end mill
2. Straight shank end mill
3. Shell end mill

51. How are gears manufactured?

Gears are manufactured by various processes. They are:

- ✓ Casting

- ✓ Stamping
- ✓ Rolling
- ✓ Extruding
- ✓ Powder Metallurgy
- ✓ Machining

52. Write how the gear teeth produced by machining.

Gear teeth are produced by machining based on:

- Forming – where the profile of the teeth are obtained as the replica of the form of the cutting tool (edge); e.g., milling, broaching etc.
- Generation – where the complicated tooth profile are provided by much simpler form cutting tool (edges) through rolling type, tool – work motions, e.g., hobbing, gear shaping etc.

53. How are gears formed by disc cutter?

The disc cutter shape conforms to the gear tooth space. Each gear needs a separate cutter. However, with 8 to 10 standard cutters, gears from 12 to 120 teeth can be cut with fair accuracy. Tooth is cut one by one by plunging the rotating cutter into the blank.

54. What is indexing?

Indexing is an operation of dividing the periphery of a piece of work into any number of equal parts.

55. What are the different methods of indexing?

1. Direct Indexing
2. Simple Indexing
3. Compound Indexing
4. Differential Indexing

56. What is gear finishing?

For smooth running, good performance and long service life, the gears need

- to be accurate in dimensions and forms
- to have high surface finish and
- to be hard and wear resistive at their tooth flanks

57. List the gear finishing methods.

Common methods of gear teeth finishing

Gear teeth, after preforming and machining, are finished generally by;

- For soft and unhardened gears
 - ❖ Gear shaving
 - ❖ Gear rolling or burnishing
- For hard and hardened gears
 - ❖ Grinding
 - ❖ Lapping

58. How are spur gears manufactured?

Cutting of a Spur Gear on a Milling Machine involves the following steps:

1. To determine the important dimensions and proportions of the gear tooth element.
2. Mounting the cutter and the job on the machine.
3. Adjust the position of the table to the starting position.
4. Indexing.
5. Repeat the operation till the gear is complete.

59. Define hobbing.

The process of generating a gear by means of a rotating cutter call hob is known as hobbing.

60. What is lapping and honing?

- Lapping and honing both employ an abrasive-impregnated gear or gear-shaped tool that is run against the gear to abrade the surface.
- In both cases, the abrasive tool drives the gear in what amounts to an accelerated and controlled run-in to improve surface finish and the accuracy.

PART – B

1. Describe the principle of operation of a shaper with a neat sketch. (Nov/Dec 2010) (April/May 2016)

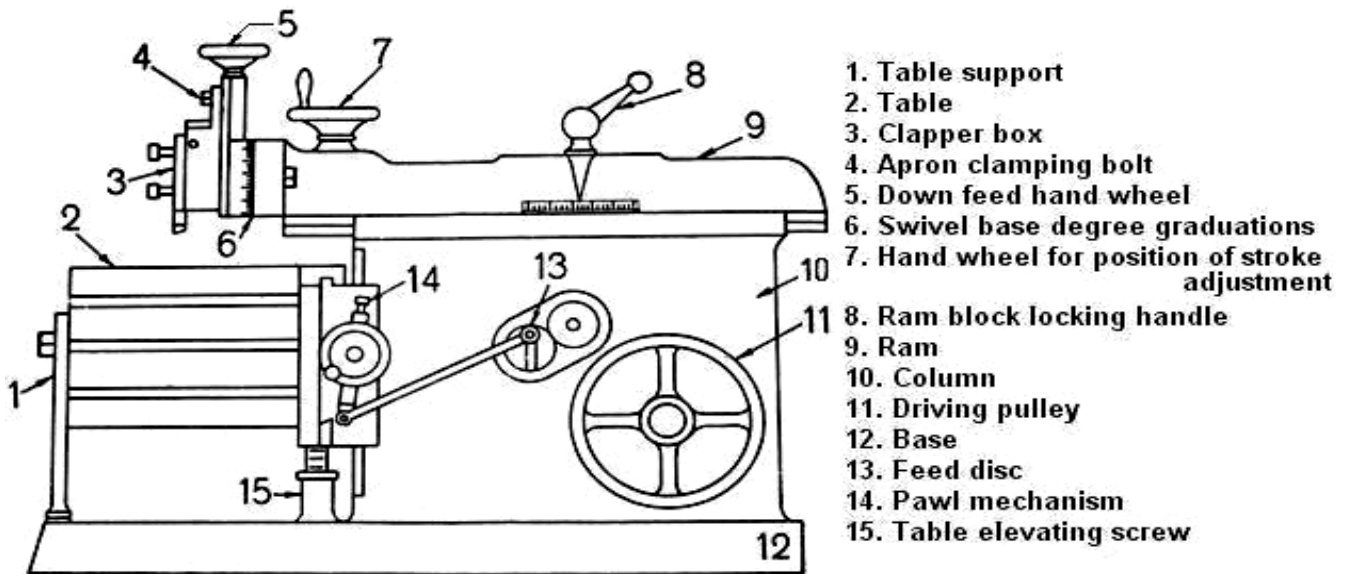

Fig. Schematic view of a standard shaper

Base

- It is rigidly bolted to the shop floor. All parts are mounted on the base.
- It is made up of cast iron to resist vibration and take up high compressive load.
- It takes the entire load of the machine and the forces set up by the cutting tool during machining.

Column

- Two accurately machined guide ways are provided on the top of the column on which the ram reciprocates.
- The front vertical face of the column which serves as the guide ways for the cross rail is also accurately machined.

Cross rail

- It is mounted on the front vertical guide ways of the column. It has two parallel guide ways on its top in the vertical plane that is perpendicular to the ram axis.
- The table may be raised or lowered to accommodate different sizes of jobs by rotating an elevating screw which causes the cross rail to slide up and down on the vertical face of the column.

Saddle

- It is mounted on the cross rail which holds the table firmly on its top. Crosswise movement of the saddle by rotating the cross feed screw by hand or power causes the table to move sideways.

Table

- It is bolted to the saddle receives crosswise and vertical movements from the saddle and cross rail. It is a box like casting having T-slots both on the top and sides for clamping the work.
- In a universal shaper the table may be swiveled on a horizontal axis and the upper part of the table may be tilted up or down.

Ram

- ❖ It holds and imparts cutting motion to the tool through reciprocation. It is connected to the reciprocating mechanism contained within the column.

- ❖ It is semi cylindrical in form and heavily ribbed inside to make it more rigid. It houses a screwed shaft for altering the position of the ram with respect to the work and holds the tool head at the extreme forward end.

Tool head

- ❖ It holds the tool rigidly, provides the feed movement of the tool and allows the tool to have an automatic relief during its return stroke.
- ❖ The vertical slide of the tool head has a swivel base which is held on a circular seat on the ram. So the vertical slide may be set at any desired angle.
- ❖ By rotating the down feed screw handle, the vertical slide carrying the tool executes the feed or depth of cut. The amount of feed or depth of cut may be adjusted by a micrometer dial on the top of the down feed screw.
- ❖ Apron consisting of clapper box, clapper block and tool post is clamped upon the vertical slide by a screw. By releasing the clamping screw, the apron may be swiveled upon the apron swivel pin with respect to the vertical slide.

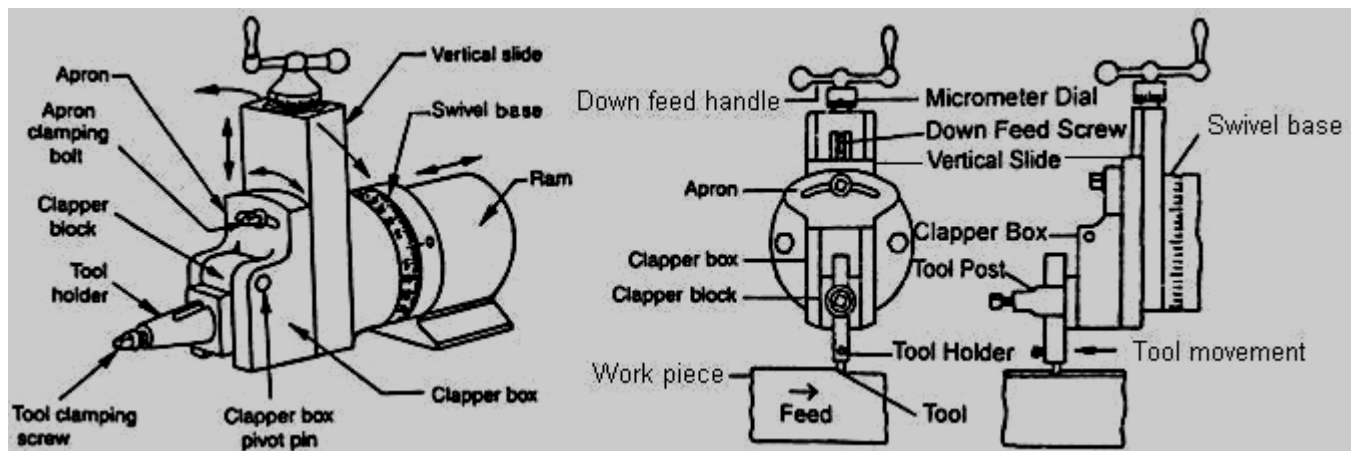

Fig. Tool head of a shaper

- ❖ This arrangement is necessary to provide relief to the tool while making vertical or angular cuts. The two vertical walls on the apron called clapper box houses the clapper block which is connected to it by means of a hinge pin.
- ❖ The tool post is mounted upon the clapper block. On the forward cutting stroke the clapper block fits securely to the clapper box to make a rigid tool support.

Working principle:

- ❖ The bull gear receives its rotation from the motor through the pinion.
- ❖ The rotation of the crank causes oscillation of the link and thereby reciprocation of the ram and hence the tool in straight path.
- ❖ The cutting motion provided by the reciprocating tool and the intermittent feed motion provided by the slow transverse motion of the work at different rate by using the ratchet - pawl system along with the saddle result in producing a flat surface by gradual removal of excess material layer by layer in the form of chips.
- ❖ The vertical in feed is given either by descending the tool holder or raising the cross rail or both. Straight grooves of various curved sections are also made in shaper by using specific form tools.
- ❖ The single point straight or form tool is clamped in the vertical slide of the tool head, which is mounted at the front face of the reciprocating ram.
- ❖ The work piece is clamped directly on the table or clamped in a vice which is mounted on the table.

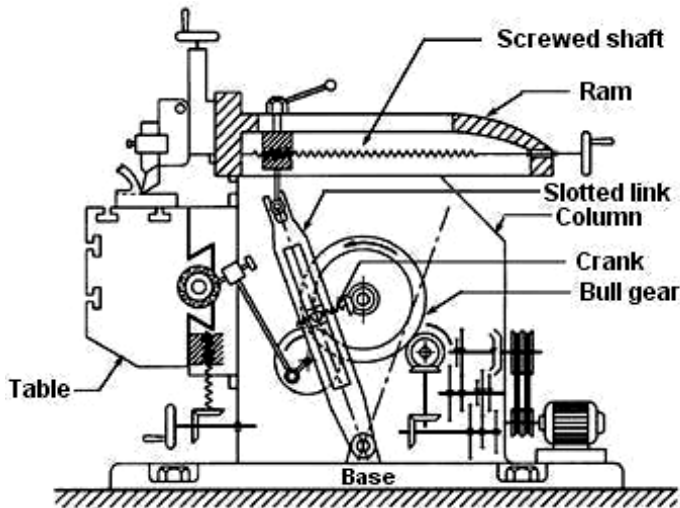

Fig. 3 (a) Kinematic system of a shaper

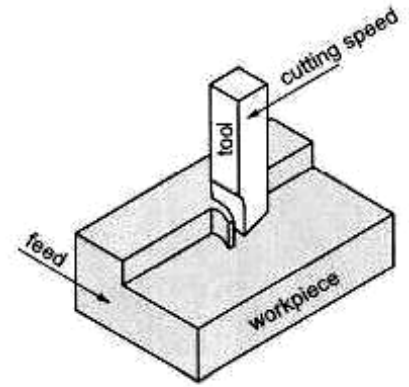

Fig. 3 (b) Principle of producing flat surface

The changes in length of stroke and position of the stroke required for different machining are accomplished respectively by:

- Adjusting the crank length by rotating the bevel gear mounted coaxially with the bull gear.
- Shifting the ram block nut by rotating the lead screw.

TYPE OF DRIVE MECHANISM

The following are three type of drive mechanism are:

1. Crank and slotted link quick return mechanism
2. Whitworth quick return mechanism
3. Hydraulic drive

2. Describe the working of a crank and slotted link mechanism. (Nov/ Dec 2003 & 2010)

- This mechanism has a bull gear mounted within the column. The motion or power is transmitted to the bull gear through a pinion which receives its motion from an individual motor.
- A radial slide is bolted to the centre of the bull gear. This radial slide carries a bull gear sliding block into which the crank pin is fitted.
- Rotation of the bull gear will cause the crank pin to revolve at a constant speed about the centre of the bull gear.
- Rocker arm sliding block is mounted upon the crank pin and is free to rotate about the pin. The rocker arm sliding block is fitted within the slotted link and can slide along the slot in the slotted link (rocker arm).
- The bottom end of the rocker arm is pivoted to the frame of the column. The upper end is forked and connected to the ram block by a pin which can slide in the forked end.
- As the bull gear rotates causing the crank pin to rotate, the rocker arm sliding block fastened to the crank pin will rotate on the crank pin circle, and at the same time will move up and down in the slot provided in the slotted link.
- This up and down movement will give rocking motion (oscillatory motion) to the slotted link (rocker arm), which communicated to the ram. Thus the rotary motion of the bull gear is converted into reciprocating movement of the ram.

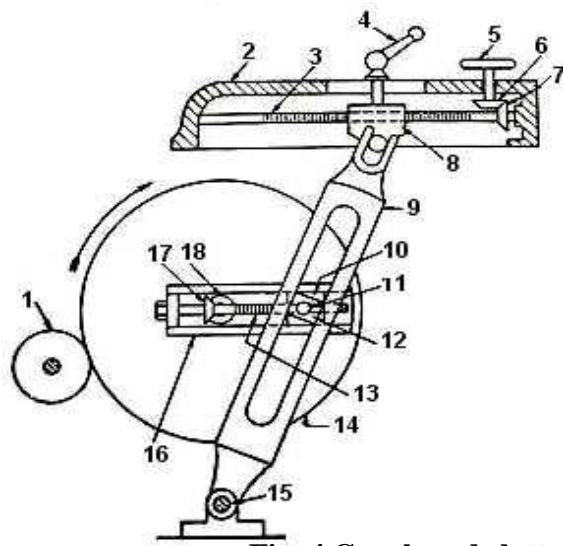

1. Driving pinion
2. Ram
3. Screwed shaft
4. Ram block locking handle
5. Hand wheel for position of stroke adjustment
- 6, 7. Bevel gears for rotating screwed shaft
8. Ram Block
9. Slotted link or rocker arm
10. Bull gear sliding block
11. Crank pin
12. Rocker arm sliding block
13. Lead screw
14. Bull gear
15. Rocker arm pivot
16. Radial slide
- 17, 18. Bevel gears for rotating lead screw

Fig. 4 Crank and slotted link quick return mechanism

Quick return principle

- When the slotted link is in the position PA_1 , the ram will be at the extreme backward position of its stroke.
- When the slotted link is in the position PA_2 , the ram will be at the extreme forward position of its stroke. PA_1 and PA_2 are shown tangent to the crank pin circle.
- Therefore the forward cutting stroke takes place when the crank pin rotates through the angle C_1KC_2 (α) and the return stroke takes place when the crank pin rotates through the angle C_2LC_1 (β).
- It is clear that the angle α made by the forward or cutting stroke is greater than that the angle β described by the return stroke.
- The angular velocity of the crank pin being constant, therefore the return stroke is completed within a shorter time for which it is known as quick return motion.
- The only disadvantage of this mechanism is that the linear velocity of the ram is not constant throughout the stroke. The velocity is minimum, when the rocker arm is at the two extremities and the velocity is maximum when the rocker arm is vertical.

Adjusting the length of stroke

- The crank pin is fastened to the bull gear sliding block which can be adjusted and the radius of its travel may be varied. The bevel gear 18 placed at the centre of the bull gear may be rotated by a handle causing the bevel gear 17 to rotate.
- The bevel gear 17 is mounted upon the small lead screw which passes through the bull gear sliding block.

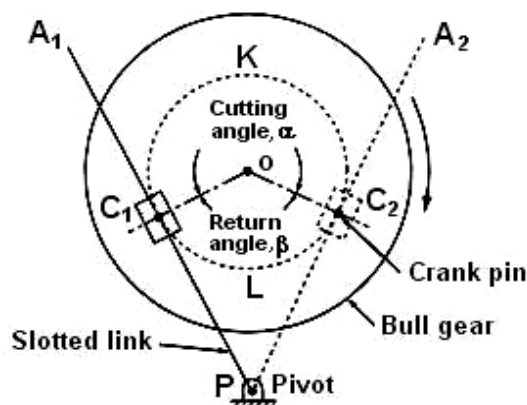

Fig. Principle of quick return motion

- Thus rotation of the bevel gear will cause the bull gear sliding block carrying the crank pin to be brought inwards or outwards with respect to the centre of the bull gear.
- The sketch has been drawn without the rocker arm in position.

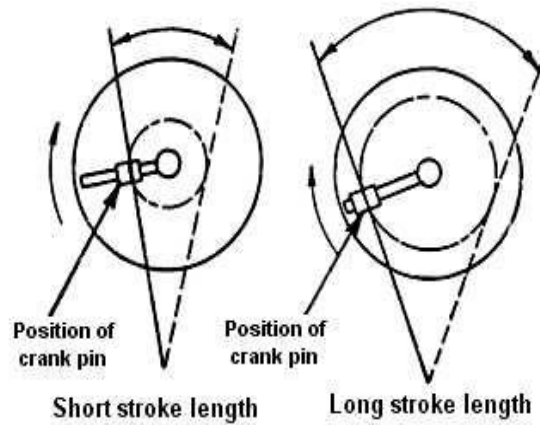
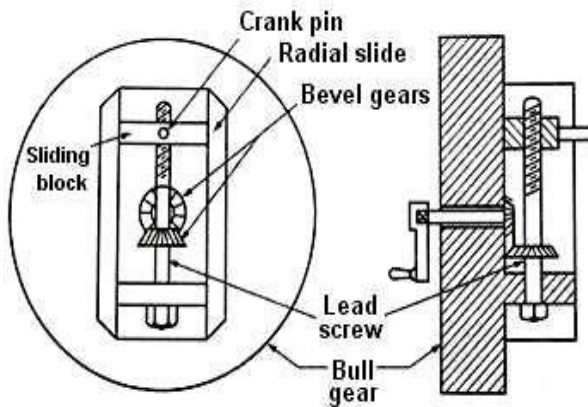

Fig. (a) Arrangement of bull gear sliding block

Fig. (b) Short and long stroke length

Adjusting the position of stroke

- The position of the ram relative to the work can also be adjusted. Referring to the Fig. 4, by rotating the hand wheel 5 the screwed shaft fitted in the ram may be made to rotate through two bevel gears 6 and 7.
- The ram block which is mounted upon the screwed shaft acts as a nut. The nut remaining fixed in position, rotation of the screwed shaft will cause the ram to move forward or backward with respect to the ram block according to the direction of rotation of the hand wheel.
- Thus the position of ram may be adjusted with respect to the work piece. The ram block locking handle 4 must be tightened after the adjustment has been made.

3. Describe with neat sketch whit worth quick return mechanism used in a shaper. (May/ June 2006)

- The bull gear is mounted on a large fixed pin A upon which it is free to rotate. The motion or power is transmitted to the bull gear through a pinion which receives its motion from an individual motor.
- The crank plate is pivoted eccentrically upon the fixed pin at 5. The crank pin is fitted on the face of the bull gear. The crank plate sliding block is mounted upon the crank pin and it fits into the slot provided on the crank plate. The crank plate sliding block can slide inside the slot.

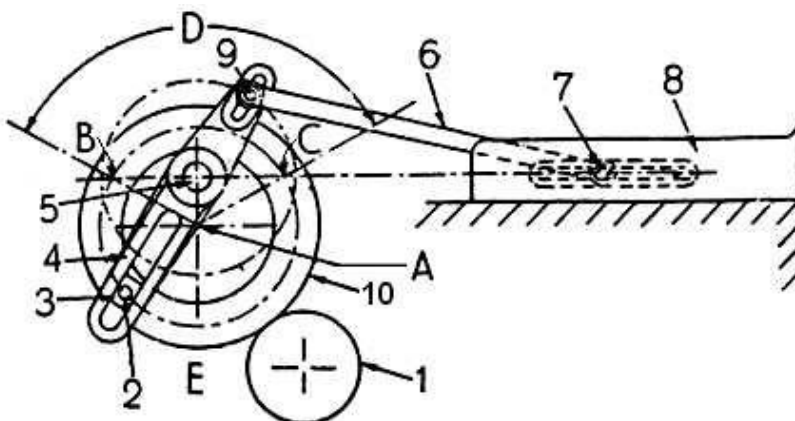

- A. Fixed pin
- 1. Driving pinion
- 2. Crank pin
- 3. Crank plate sliding block
- 4. Crank plate
- 5. Pivot for crank plate
- 6. Connecting rod
- 7. Connecting pin for ram
- 8. Ram
- 9. Connecting pin for crank plate
- 10. Bull gear

Fig. 7 Whitworth quick return mechanism

- At the other end of the crank plate, a connecting rod connects the crank plate and the ram by two pin 9 and 7. When bull gear will rotate at a constant speed the crank pin with the sliding block

will rotate on a crank circle of radius A and the sliding block will cause the crank plate to rotate about the point 5 with a variable angular velocity.

- When the crank pin 2 is at the point C the ram will be at the extreme backward position of its stroke. When the crank pin 2 is at the point B the ram will be at the extreme forward position of its stroke.
- Therefore the forward cutting stroke takes place when the crank pin rotates through the angle CEB (α) and the return stroke takes place when the crank pin rotates through the angle BDC (β).

- It is clear that the angle α made by the forward or cutting stroke is greater than the angle β described by the return stroke.
- The angular velocity of the crank pin being constant, therefore the return stroke is completed within a shorter time for which it is known as quick return motion. The length of stroke of the ram may be changed by shifting the position of pin 9 closer or away from the pivot 5.
- The position of stroke may be altered by shifting the position of pin 7 on the ram.

4. Explain the hydraulic drive quick return mechanism of a horizontal shaper with a neat sketch.

(May/ June 2014)

- A constant speed motor drives a hydraulic pump which delivers oil at a constant pressure to the line.
- A regulating valve admits oil under pressure to each end on the piston alternately, at the same time allowing oil from the opposite end of the piston to return to the reservoir.
- The piston is pushed by the oil and, being connected to the ram by the piston rod, pushes the ram carrying the tool. The admission of oil to each end of the piston, alternately, is accomplished with the help of trip dogs and pilot valve.
- As the ram moves and completes its stroke (forward or return) a trip dog will trip the pilot valve which operates the regulating valve.
- The regulating valve will admit the oil to the other side of the piston and the motion of the ram will get reversed. It is clear that the length of the ram stroke will depend upon the position of the trip dogs.
- The length of the ram stroke can be changed by unclamping and moving the trip dogs to the desired positions. The above system is a constant pressure system.
- The velocity of the ram travel will be directly proportional to the oil pressure and the piston area to which it is applied.
- The return stroke is quicker, since the piston area on which the oil pressure acts is greater as compared to the other end for which it gets reduced because of the piston rod.
- Another oil line is connected to a smaller feed cylinder to change the hydraulic power to mechanical power for feeding the work past the tool.

Advantages of Hydraulic drive

- Does not make any noise and operates very quietly.
- Ability to stall against an obstruction without damage to the tool or the machine.
- Ability to change length and position of stroke or speed while the machine is running.
- The cutting and return speeds are practically constant throughout the stroke. This permits the cutting tool to work uniformly during cutting stroke.

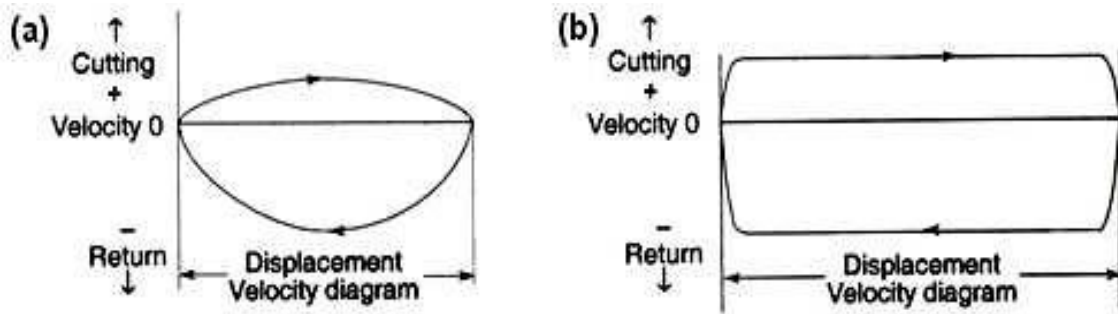

Fig. Velocity diagram of (a) Crank shaper and (b) Hydraulic shaper

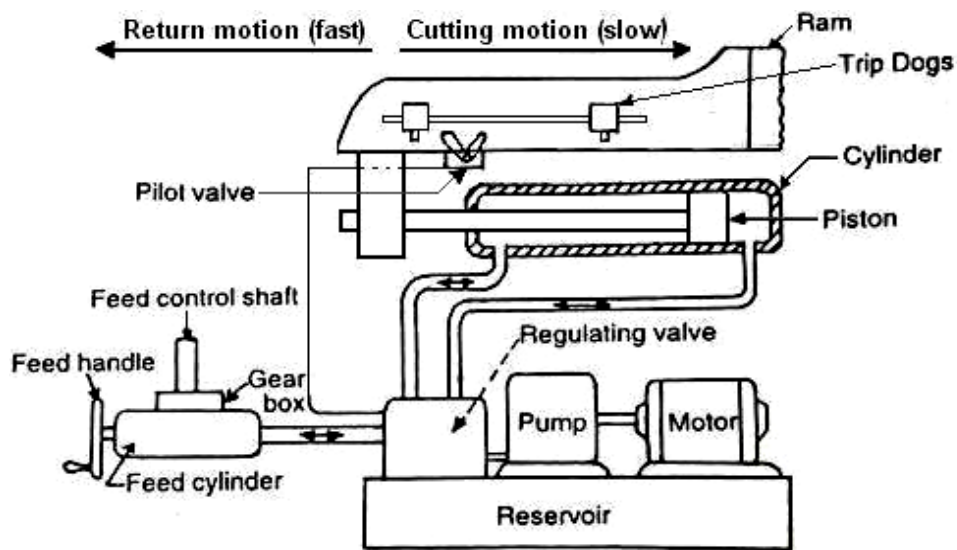
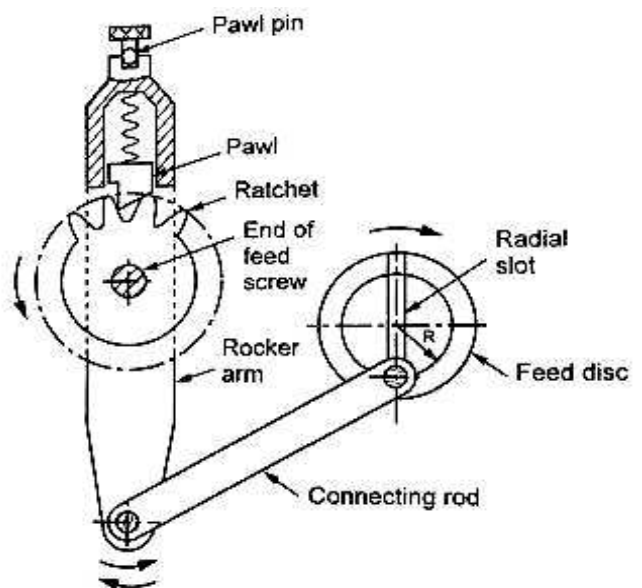
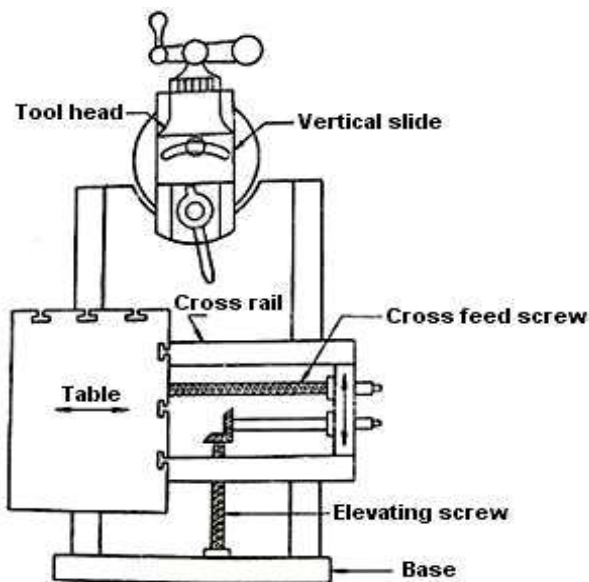

Fig. Hydraulic drive for horizontal shaper

On the other hand, a mechanical shaper has the following plus points: Lower first cost and simpler in operation. The cutting stroke has a definite stopping point.

5. Explain in detail the three types of feed mechanism.



The feed mechanism in which the feed is given at the end of each return stroke is known as **feed mechanism**.

1. Hand feed

- ❖ The table is moved perpendicular to the ram movement it is called as cross feed. It is given by rotating the hand wheel of the cross feed screws on the tool head.
- ❖ The vertical adjustment is made by rotating the elevating screw through the horizontal rod to hold the work piece at various heights.
- ❖ Both vertical and angular feeds are given by the tool head. But the only difference in angular feed is that the feed will be given after setting the work to its required angle.

2. Automatic feed mechanism of a shaper

- ❖ In this mechanism, a ratchet wheel is keyed to the end of the cross feed screw. A rocker arm is pivoted at the centre of the ratchet wheel.
- ❖ The rocker arm houses a spring loaded pawl at its top. The spring pushes against the pawl to keep it in contact with the ratchet wheel.
- ❖ The pawl is straight on one side and bevel on the other side. So the pawl moves the ratchet wheel in one direction only.
- ❖ The rocker arm is connected to the driving disc or feed disc by a connecting rod. The driving disc has a T-slot on its face along its diameter. The driving pin or crank pin fits into this slot. One end of the connecting rod is attached to this crank pin.
- ❖ We know that the table feed is intermittent and is accomplished on the return stroke when the tool has cleared the work piece.
- ❖ The driving disc is driven from the bull gear through a spur gear drive and rotates at the same speed as the bull gear. As the driving disc rotates, the connecting rod oscillates the rocker arm about the cross feed screw.
- ❖ During the forward stroke of the ram, the rocker arm moves in the clockwise direction. As bevel side of the pawl fits on the right side, the pawl slips over the teeth of the ratchet wheel. It gives no movement to the table.
- ❖ During the return stroke of the ram, the rocker arm moves in the counter clockwise direction. The left side of the pawl being straight; so that it moves the ratchet wheel by engaging with it and hence rotates the cross feed screw which moves the table.
- ❖ A knob at the top of the pawl enables the operator to rotate it 180° to reverse the direction of feed or 90° to stop it altogether. The rate of feed is controlled by adjusting the eccentricity or offset of the crank pin in the driving disc.

6. With neat sketch and explain in detail of work holding devices in shaper.

WORK HOLDING DEVICES USED IN A SHAPER

The top and side of the table of a shaper have T-slots for clamping the work piece. The work piece may be supported on the shaper table by using any one of the following work holding devices depending upon the geometry of the work piece and nature of the operation to be performed.

- Machine vise.
- Clamping work on the table.
- Angle plate.
- V-blocks.

➤ Shaper Centre

A vise is a quick method of holding and locating small and regular shaped work pieces. It consists of a base, screw, fixed jaw and movable jaw. The work piece is clamped between fixed and movable jaws by rotating the screw. Types of machine vise are plain vise, swivel vise and universal vise.

- ❖ A **plain vise** is the most simple of all the types. The vise may have a single screw or double screws for actuating the movable jaw. The double screws add gripping strength while taking deeper cuts or handling heavier jobs.
- ❖ In a **swivel vise** the base is graduated in degrees, and the body of the vise may be swiveled at any desired angle on a horizontal plane. The swiveling arrangement is useful in beveling the end of work piece.
- ❖ A **universal vise** may be swiveled like a swivel vise. In addition to that, the body may be tilted in a vertical plane up to 90 degrees from the horizontal. An inclined surface may be machined by a universal vise.

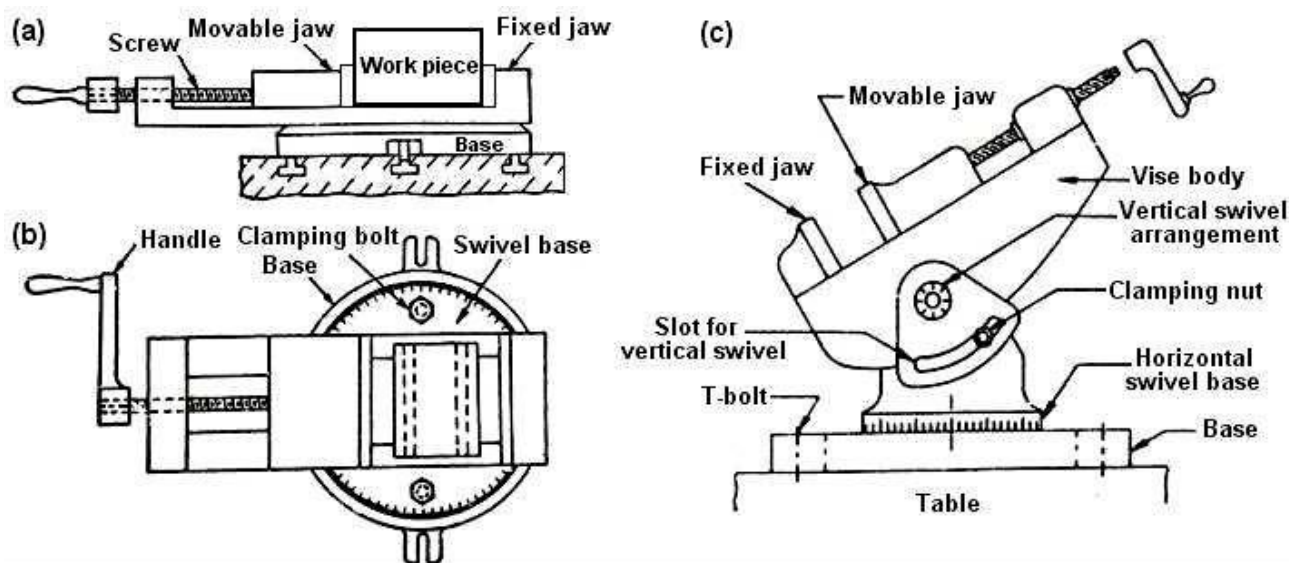

Fig. Machine vise (a) Plain vise (b) Swivel vise and (c) Universal vise

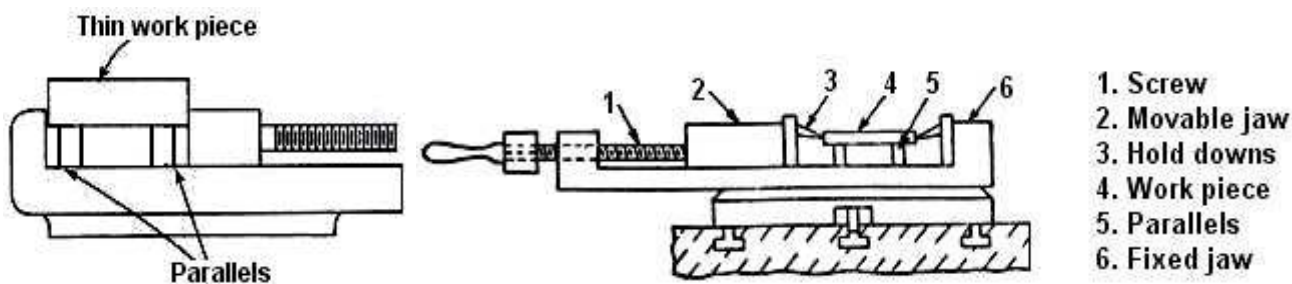

Fig. Use of parallels

Parallels

- ❖ When the height of the job is less than the height of the jaws of the vise, parallels are used to raise and seat the work piece above the vise jaws and parallel with the vise bottom. Parallels are square or rectangular hardened bars of steel or cast iron.

Hold downs

- ❖ Hold downs or grippers are used for holding thin pieces of work in a shaper vise. These are also used for holding work of smaller height than the vise jaws. These are hardened wedge shaped piece with a taper angle of 5° .
- ❖ These are placed between two jaws of the vise and the work piece. When the screw is tightened the typical shape of the hold down exerts downward pressure on the work to hold it tight on the parallels or on the vise table.

Clamping work on the table

When the work piece is too large to be held in a vise it must be fastened directly on the shaper table. The different methods employed to clamp different types of work on a shaper table are:

- T-bolts, step blocks and clamps.
- Stop pins.
- Stop pins and toe dogs.
- Strip and stop pins.

T-bolts, step blocks and clamps

- ❖ T-bolt having T-head is fitted in the T-slot of the table. The length of the threaded portion is sufficiently long in order to accommodate different heights of work.
- ❖ One end of the clamp rests on the side of the work while the other end rests on a fulcrum block or step block. The fulcrum block should be of the same height as the part being clamped.
- ❖ To hold a large work on the table a series of clamps and T-bolts are used all round the work.

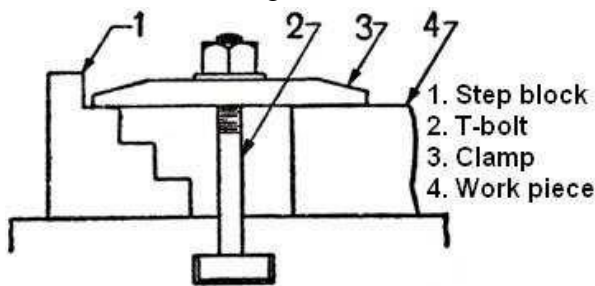

Fig. Use of T-bolt, step block and clamp

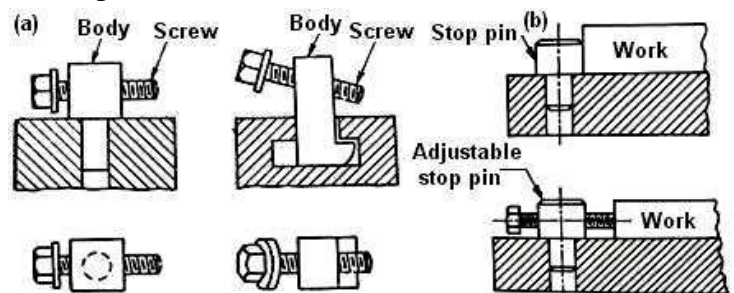

Fig. (a) Stop pins and (b) Use of stop pins

Stop pins

- ❖ A stop pin is a one-leg screw clamp. Stop pins are used to prevent the work piece from coming out of position during the cutting stroke. The body of the stop pin is fitted in the slot on the table and the screw is tightened till it forces against the work.

Stop pins and toe dogs

- ❖ While holding thin work on the table stop pins in conjunction with toe dogs are used. A toe dog is similar in shape to that of a centre punch or a cold chisel.
- ❖ When screw of the stop pin is tightened, the work is gripped down on the table.

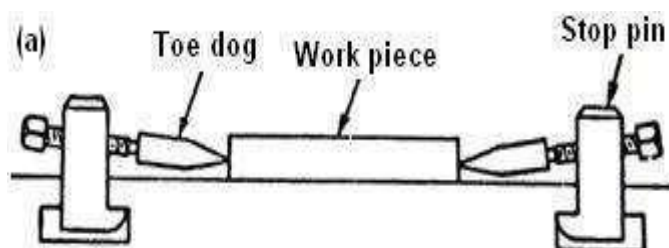

Fig. (a) Use of stop pins and toe dogs

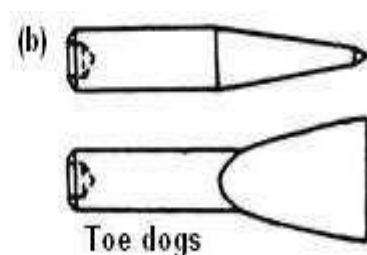

Fig. (b) Toe dogs

Strip and stop pin

Work having sufficient thickness is held on the table by strip and stop pin. A strip is a long bar having a tongue with holes for fitting the T-bolts. The strip with bolts is fitted in the T-slot of the table.

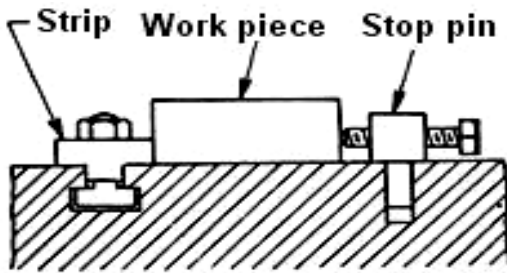

Fig. 18 Use of strip and stop pin

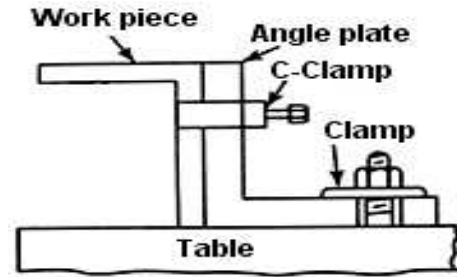

Fig. 19 Use of angle plate

Angle plate

- ❖ For holding “L” shaped work piece, angle plate is used. Angle plate is made of cast iron and is accurately planed on two sides at right angles.
- ❖ One of the sides is clamped to the table by T-bolts while the other side holds the work by clamps.

V-blocks

- ❖ V-blocks are used for holding round rods. Work piece may be supported on two V-blocks at its two ends and is clamped to the table by T-bolts and clamps.
- ❖ V-blocks are made of cast iron or steel and are accurately machined.

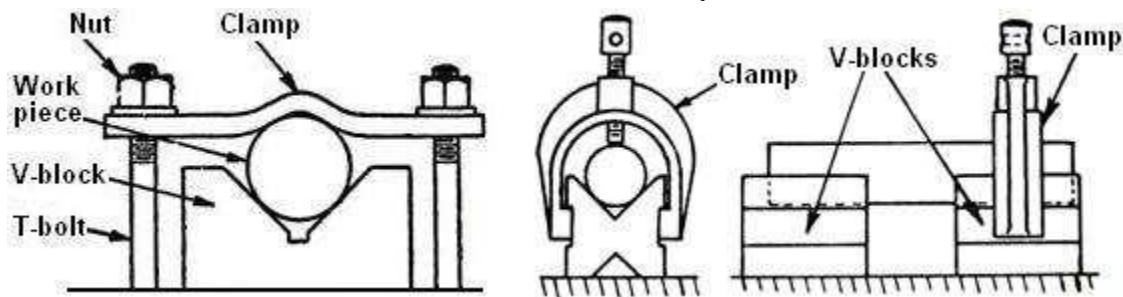
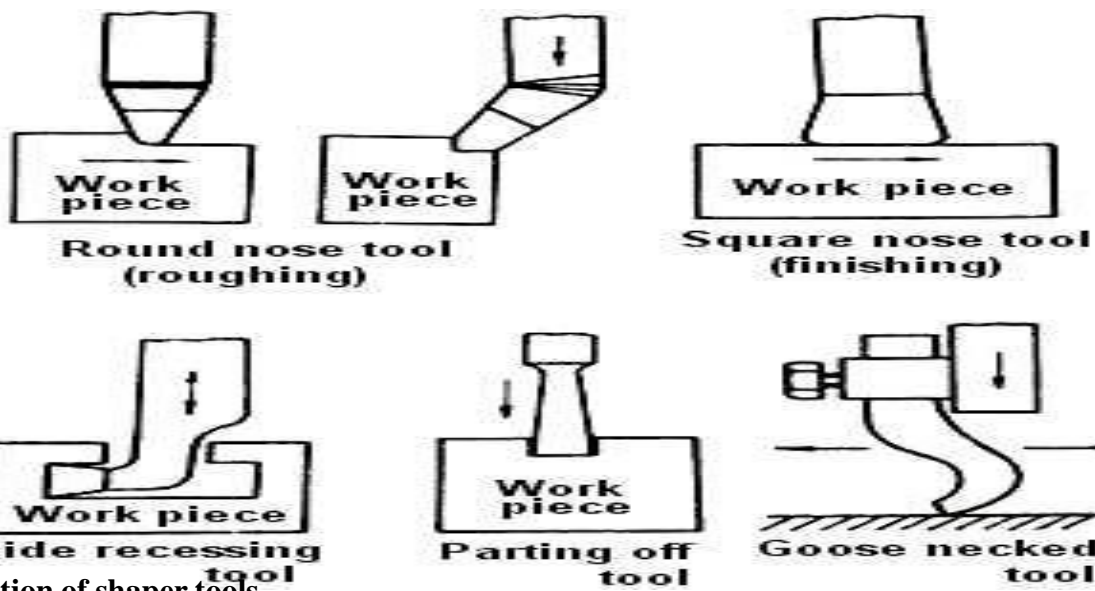

Fig. Use of V-block

7. Write the classification of shaper.

SHAPER TOOLS

- ❖ The cutting tool used in a shaper is a single point cutting tool having rake, clearance and other tool angles similar to a lathe tool. It differs from a lathe tool in tool angles.
- ❖ Shaper tools are much more rigid and heavier to withstand shock experienced by the cutting tool at the commencement of each cutting stroke.
- ❖ In a shaper tool the amount of side clearance angle is only 2° to 3° and the front clearance angle is 4° for cast iron and steel. Small clearance angle adds strength to the cutting edge.



Classification of shaper tools

The shaper tools are classified as follows:

According to the shape:

- Straight tool.
- Cranked tool.
- Goose necked tool.

According to the direction of cutting:

- Left hand tool.
- Right hand tool.

According to the finish required:

- Roughing tool.
- Finishing tool.

According to the type of operation:

- Down cutting tool.
- Parting off tool.
- Squaring tool.
- Side recessing tool.

According to the shape of the cutting edge:

- Round nose tool.
- Square nose tool

Round nose tool:

- ❖ This is used for roughing operations. The tool has no top rake. It has side rake angle, in between 10° to 20° . Round tool is of two types - plain and bent types.
- ❖ The plain straight type is used for rough machining of horizontal surface. Round nose tool can be left handed or right handed.
- ❖ Another type of round nose tool which is cranked or bent is used for machining vertical surfaces. It is known as round nose cutting down tool.

Square nose tool:

- ❖ This tool is used for finishing operations. The cutting edge may have different widths. It is also used to machine the bottom surfaces of key ways and grooves.

Side recessing tool:

- ❖ This is a special tool used for machining T-slots and narrow vertical surfaces. This tool can be both left handed and right handed.

Parting off tool:

- ❖ This is used for parting off operation. It is also used for cutting narrow slots. It has no side rake angle. It has front and side clearance angle of 3° .

Goose necked tool:

- ❖ This is also known as spring tool. The special shape of tool reduces chatter and prevents digging of tool into the work piece. This tool is generally used for finishing cast iron.

8. Write short notes on shaper operations.

- ❖ A shaper is a versatile machine tool primarily designed to generate a flat surface by a single point cutting tool. But it may also be used to perform many other operations. The different operations which a shaper can perform are as follows:

Machining flat surfaces in different planes

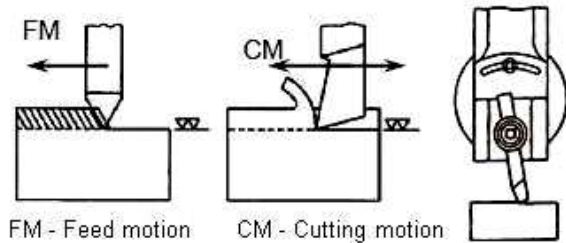

(a) Horizontal surface

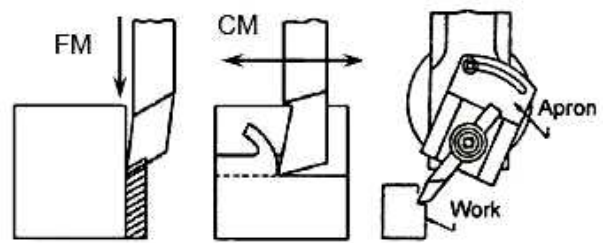

(b) Vertical surface

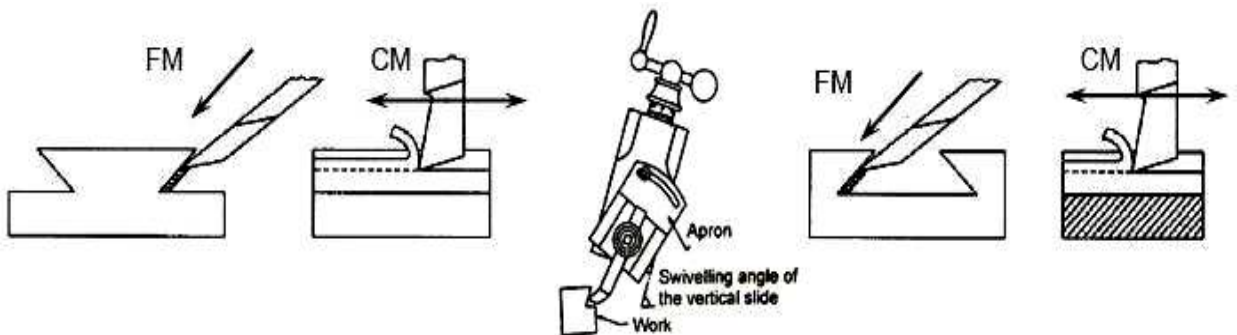

(a)

(c) Inclined surfaces (dovetail slides and guides)

Fig. Machining of flat surfaces in a shaper

Making features like slots, steps etc. which are also bounded by flat surfaces

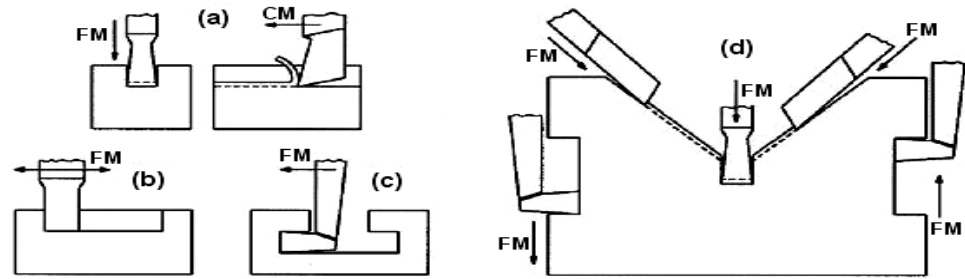

Fig. Machining (a) Slot (b) Pocket (c) T-slot and (d) V-block in a shaper
Forming grooves bounded by short width curved surfaces

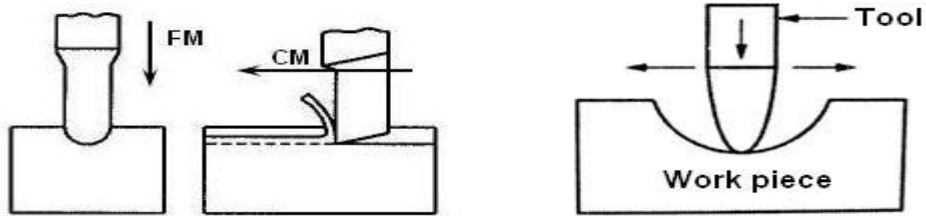

Fig. Making grooves in a shaper by form tools

Cutting external and internal keyways

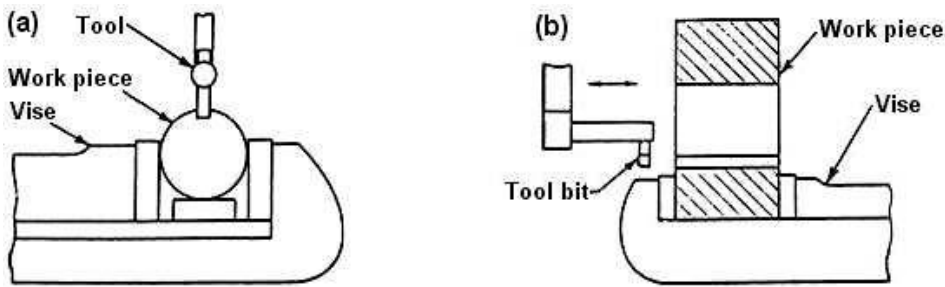

Fig. Machining of (a) External keyway and (b) Internal keyway in a shaper

The methods of machining (a) External keyway and (b) Internal keyway in a shaper by using single point tools.

Machining of external gears, external and internal spline

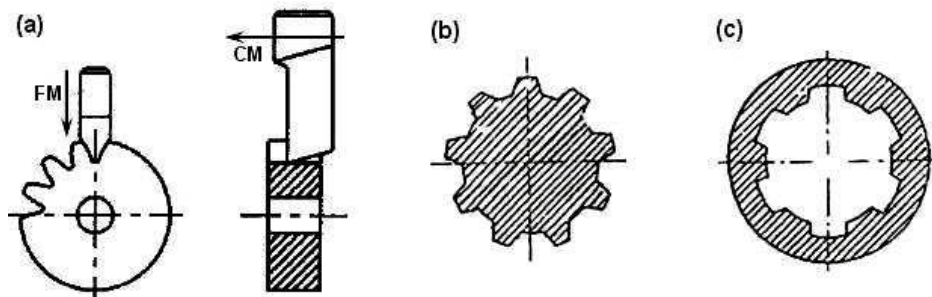

Fig. Machining of (a) External gear (b) External splines and (c) Internal splines in a shaper

Some other machining applications of shaper are smooth slitting or parting, cutting teeth of rack for repair etc. using simple or form type single point cutting tools. Some unusual work can also be done, if needed, by developing and using special attachments. However, due to very low productivity, less versatility and poor process capability, shapers are not employed for lot and batch production.

DRILLING

Drilling is the process of originating holes in the work piece by using a rotating cutter called drill. The machine used for this purpose is called drilling machine. Although it was primarily designed to originate a hole, it can perform a number of similar operations. In a drilling machine holes may be drilled quickly and at a low cost. As the machine tool exerts vertical pressure to originate a hole it is also called drill press. Holes were drilled by the Egyptians in 1200 B.C. by bow drills. The bow drill is the mother of present day metal cutting drilling machine

Types of drilling machine

The different types of drilling machine which are most commonly used are:

- ❖ Portable drilling machine.
- ❖ Sensitive drilling machine (Bench mounting or table top and Floor mounting).
- ❖ Upright drilling machine (Pillar or Round column section and Box column section).
- ❖ Radial drilling machine (Plain, Semi-universal and Universal).
- ❖ Gang drilling machine.
- ❖ Multiple spindle drilling machine.
- ❖ Deep hole drilling machine.
- ❖ Turret type drilling machine

But in working principle all are more or less the same.

1. Portable drilling machine or hand drilling machine

Unlike the mounted stationary drilling machines, the hand drill is a portable drilling device which is mostly held in hand and used at the locations where holes have to be drilled. The small and reasonably light hand drilling machines are run by a high speed electric motor. In fire hazardous areas the hand drilling machine is often rotated by compressed air. The maximum size of the drill that it can accommodate is not more than 12 to 18 mm.

2. Bench mounting or table top sensitive drilling machine

This small capacity (≤ 0.5 kW) upright (vertical) single spindle drilling machine is mounted on rigid table and manually operated using usually small size ($\phi \leq 10$ mm) drills.

9. Sketch and explain the working principle of floor mounting sensitive drilling machine.

3. Floor mounting sensitive drilling machine

- ❖ The floor mounting sensitive drilling machine is a small machine designed for drilling small holes at high speed in light jobs. The base of the machine is mounted on the floor.
- ❖ It consists of a vertical column, a horizontal table, a head supporting the motor and driving mechanism, and a vertical spindle for driving and rotating the drill.
- ❖ There is no arrangement for any automatic feed of the drill spindle. The drill is fed into the work by purely hand control.



Fig. Hand drilling machine



Fig. Table top sensitive drilling machine

- ❖ High speed is necessary for drilling small holes. High speeds are necessary to attain required cutting speed by small diameter drill.
- ❖ Hand feed permits the operator to feel or sense the progress of the drill into the work, so that if the drill becomes worn out or jams on any account, the pressure on the drill may be released immediately to prevent it from breaking.
- ❖ As the operator senses the cutting action, at any instant, it is called sensitive drilling machine. Sensitive drilling machines are capable of rotating drills of diameter from 1.5 to 15.5 mm.
- ❖ Super sensitive drilling machines are designed to drill holes as small as 0.35 mm in diameter and the machine is rotated at a high speed of 20,000 r.p.m. or above.

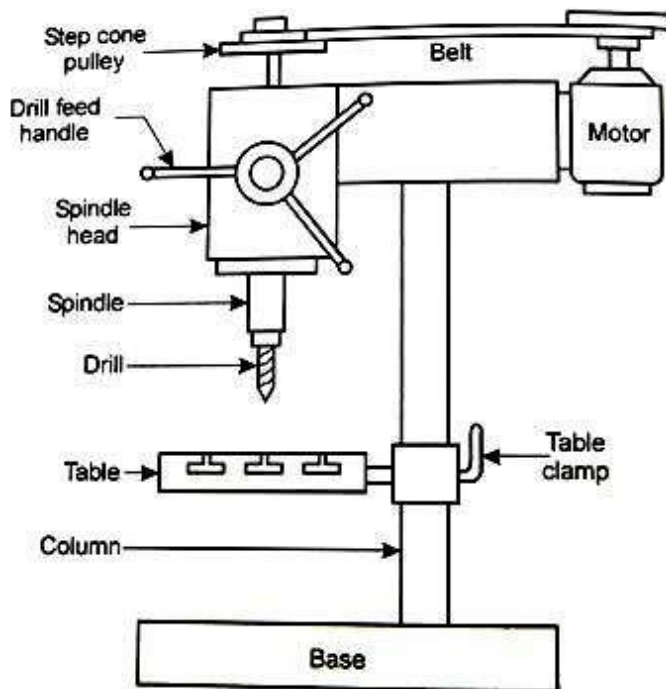

Fig. Floor mounting sensitive drilling machine



Fig. Pillar drilling machine

10. Sketch and explain the working principle of upright drilling machine. (Nov/Dec 2006)

- ❖ This machine is usually called pillar drilling machine. It is quite similar to the table top drilling machine but of little larger size and higher capacity (0.55 ~ 1.1 kW) and are mounted on the floor.
- ❖ In this machine the drill feed and the work table movements are done manually. This low cost drilling machine has a base, a tall tubular column, an arm supporting the table and a drill head assembly.
- ❖ The arm may be moved up and down on the column and also be moved in an arc up to 180° around the column. The table may be rotated 360° about its own centre independent of the position of the arm.
- ❖ It is generally used for small jobs and light drilling. The maximum size of holes that can be drilled is not more than 50 mm.

5. Box column section upright drilling machine

The major parts are:

Base: It is a part of the machine on which vertical column is mounted. The top of the base is accurately machined and has T-slots on it so that large work pieces and work holding devices may be set up and bolted to it.

Drill head: It is mounted on the top of the column and houses the driving and feeding mechanism for the spindle. In some of the machines the drill head may be adjusted up or down for accommodating different heights of work in addition to the table adjustment.

Spindle: Holds the drill and transmits rotation and axial translation to the tool for providing cutting motion and feed motion - both to the drill.

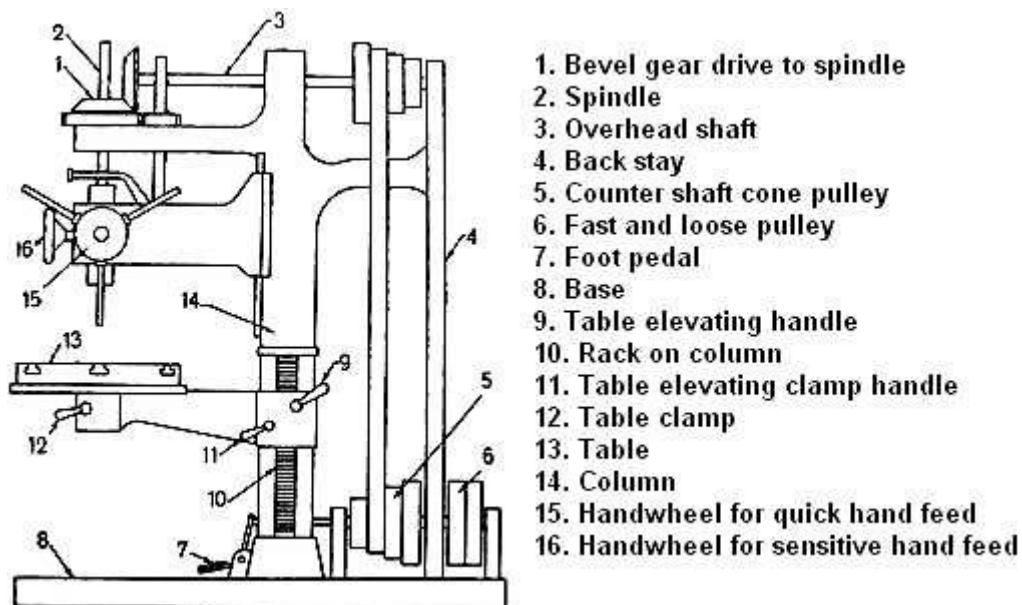

Fig. Box column section upright drilling machine

11. With a line diagram, describe the construction of radial drilling machine. (Nov/ Dec 2006).

The major parts are:

Base: It is a large rectangular casting that is finished on its top to support a column on its one end and to hold the work table at the other end. In some machines T-slots are provided on the base for clamping work when it serves as a table.

Column: The column is a cylindrical casting that is mounted vertically at one end of the base. It supports the radial arm which may slide up or down on its face.

An electric motor is mounted on the top of the column which imparts vertical adjustment of the arm by rotating a screw passing through a nut attached to the arm.

Radial arm: The radial arm that is mounted on the column extends horizontally over the base. It is a massive casting with its front vertical face accurately machined to provide guide ways on which the drill head may be made to slide. The arm may be swung round the column. In some machines this movement is controlled by a separate motor.

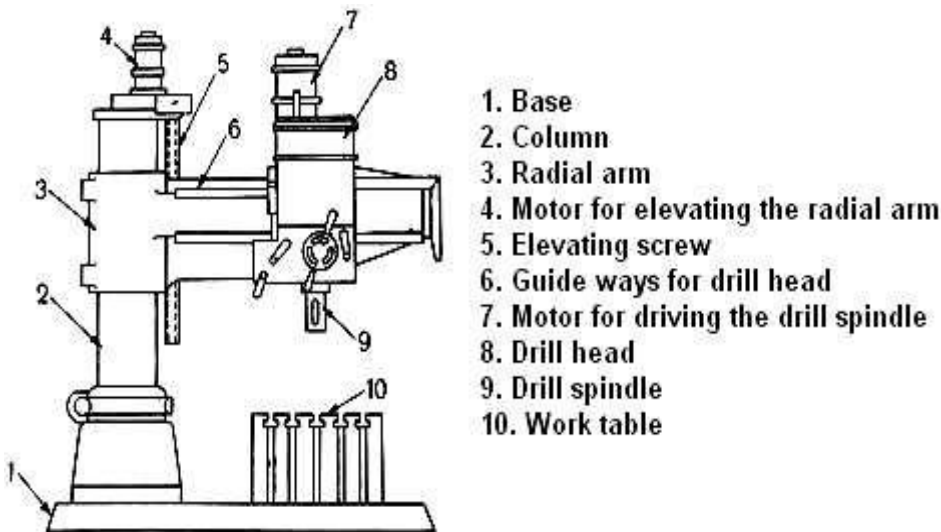

Fig. Radial drilling machine

Drill head: The drill head is mounted on the radial arm and drives the drill spindle. It encloses all the mechanism for driving the drill at multiple speeds and at different feed. All the mechanisms and controls are housed within a small drill head which may be made to slide on the guide ways of the arm for adjusting the position of drill spindle with respect to the work.

Spindle drive and feed mechanism:

There are two common methods of driving the spindle. A constant speed motor is mounted at the extreme end of the radial arm. The motor drives a horizontal spindle which runs along the length of the arm and the motion is transmitted to the drill head through bevel gears. By the gear train within the drill head, the speed of the spindle may be varied. Through another gear train within the drill head, different feeds of the spindle are obtained. In some machines, a vertical motor is fitted directly on the drill head and through gear box multiple speed and the feed of the spindle can be obtained.

Working principle

- ❖ The work is mounted on the table or when the work is very large it may be placed on the floor or in a pit.
- ❖ Then the position of the arm and the drill head is altered so that the drill may be pointed exactly on the location where the hole is to be drilled.
- ❖ When several holes are drilled on a large work piece, the drill head is moved from one position to the other after drilling the hole without altering the setting of the work.

- ❖ This versatility of the machine allows it to work on large work pieces. There are some more machines where the drill spindle can be additionally swiveled and / or tilted.

7. Gang drilling machine

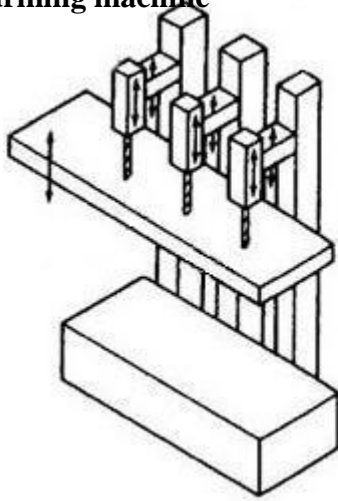

Fig. Gang drilling machine

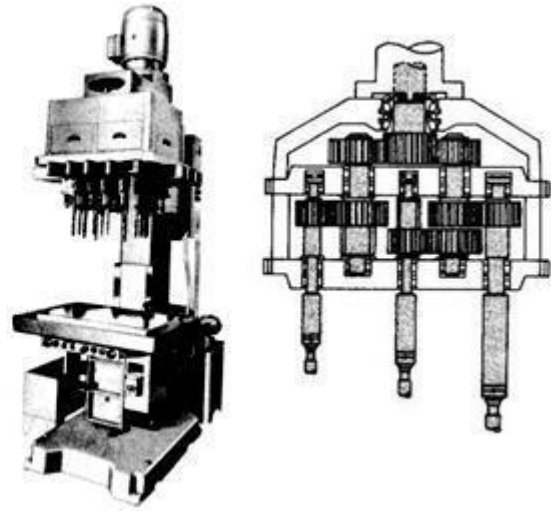

Fig. Multiple spindle drilling machines

In this almost single purpose and more productive drilling machine a number of spindles (2 to 6) with drills (of same or different size) in a row are made to produce number of holes progressively or simultaneously through the jig.

8. Multiple spindle drilling machine

- ❖ In this high production machine a large number of drills work concurrently on a blank through a jig specially made for the particular work.
- ❖ The entire drilling head works repeatedly using the same jig for batch or lot production.
- ❖ The rotations of the drills are derived from the main spindle and the central gear through a number of planetary gears in mesh with the central gear and the corresponding flexible shafts.
- ❖ The positions of those parallel shafts holding the drills are adjusted depending upon the locations of the holes to be made on the job.
- ❖ Each shaft possesses a telescopic part and two universal joints at its ends to allow its change in length and orientation respectively for adjustment of location of the drills of varying size and length.
- ❖ In some heavy duty multi spindle drilling machines, the work-table is raised to give feed motion instead of moving the heavy drilling head.

12. Write short notes on deep hole drilling. (Nov/ Dec 2013 & April/ May 2014)

- ❖ Very deep holes of L/D ratio 6 to even 30, required for rifle barrels, long spindles, oil holes in shafts, bearings, connecting rods etc, are very difficult to make for slenderness of the drills and difficulties in cutting fluid application and chip removal.
- ❖ Such drilling cannot be done in ordinary drilling machines and by using ordinary drills. It needs machines like deep hole drilling machine such as gun drilling machines with horizontal axis or vertical axis.
- ❖ These machines are provided with:

- a. High spindle speed.
- b. High rigidity.
- c. Tool guide.

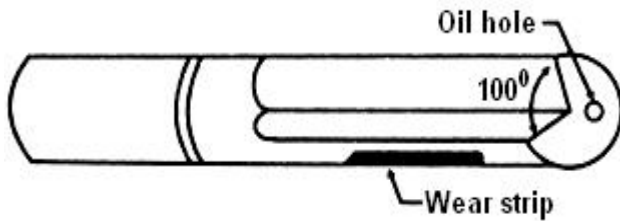

Fig. Deep hole drill

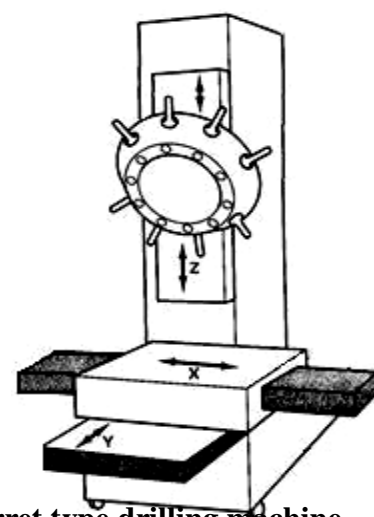

Fig. Turret type drilling machine

Turret type drilling machine

Turret drilling machine is structurally rigid column type drilling machine but is more productive like gang drill machine by having a pentagon or hexagon turret. The turret holds a number of drills and similar tools, is indexed and moved up and down to perform quickly the desired series of operations progressively. These drilling machines are available with varying degree of automation both fixed and flexible type.

13. a. Explain the feed mechanism in lathe.

In a drilling machine, the feed is effect by the vertical movement of the drill into the work. The feed movement of the drill may be controlled by hand or power.

The hand feed may be applied by two methods:

- ❖ Quick traverse hand feed.
- ❖ Sensitive hand feed.

The quick traverse feed is used to bring the cutting tool rapidly to the hole location or for withdrawing the drill when the operation is completed. Quick hand feed is obtained by rotating the hand wheel pivoted to the pinion. One turn of the hand wheel will cause the pinion to rotate through one complete revolution giving quick hand feed movement of the spindle.

The sensitive hand feed is applied for trial cut and for drilling small holes. The sensitive feed hand wheel is attached to the rear end of the worm shaft. Rotation of the hand wheel will cause the worm and worm gear to rotate and a slow but sensitive feed is obtained.

The automatic feed is applied while drilling larger diameter holes as the cutting pressure required is sufficiently great. The gear A rotates with the spindle as the spindle passes through it. Gear B is connected with gear A, so it also rotates. The shaft S rotates with the gear B as it connected to it.

At a suitable distance under the shaft, there is a worm which drives a pinion. The pinion is connected with the rack on the non-rotating sleeve (quill) fitted over the spindle. The rotation of the worm rotates the pinion.

- Deep hole drill; e.g. crank shaft drill, gun drill etc.
- General type: $L/\phi \cong 6$ to 10.
- Small length: e.g. centre drill.

According to shank:

- Straight shank - small size drill being held in drill chuck.
- Taper shank - medium to large size drills being fitted into the spindle nose directly or through taper sockets and sleeves.

According to specific applications:

- Centre drill for small axial holes with 60° taper ends to hold the lathe centre.
- Step drill and sub land drill for small holes with 2 or 3 steps.
- Half round drill, gun drill and crank shaft drill for making oil holes.
- Ejector drill for high speed drilling of large diameter holes.
- Taper drill for batch production.

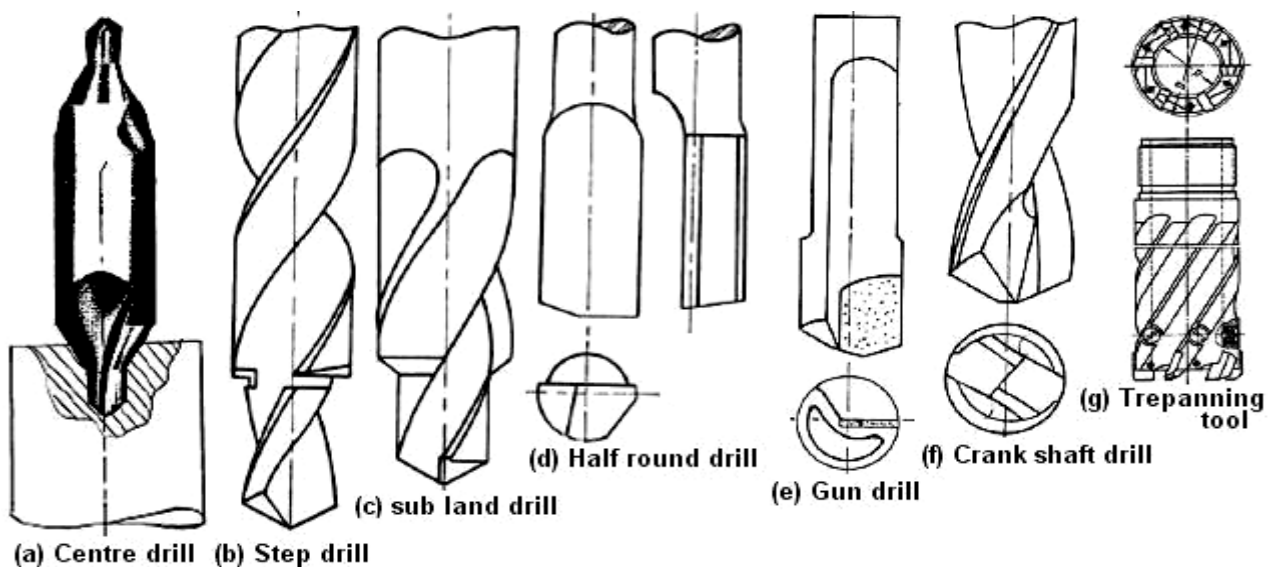

Fig. Different types of drills used in various applications

13. Explain the twist drill nomenclature and define various elements of twist drill. (April/May 2004, Nov/ Dec 2008 & May/June 2009)

Twist drill elements

Axis: The longitudinal centre line of the drill.

Body: That portion of the drill extending from its extreme point to the commencement of the neck, if present, otherwise extending to the commencement of the shank.

Body clearance: That portion of the body surface which is reduced in diameter to provide diametral clearance.

Chisel edge: The edge formed by the intersection of the flanks. The chisel edge is also sometimes called dead centre.

Chisel edge corner: The corner formed by the intersection of a lip and the chisel edge.

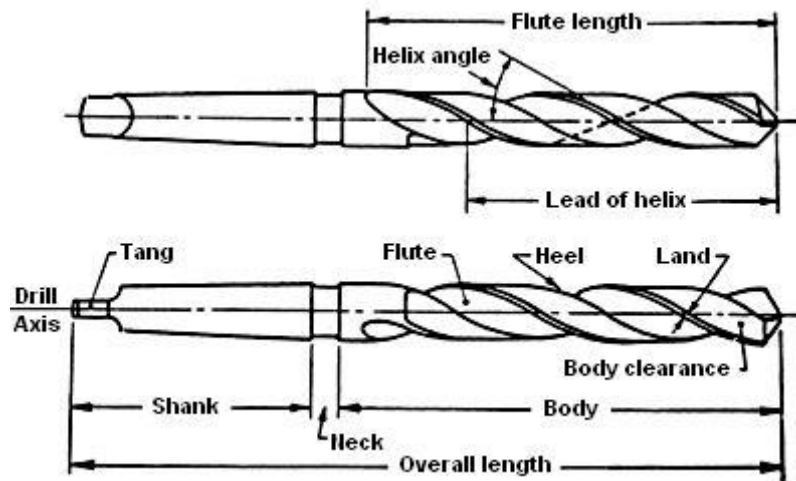
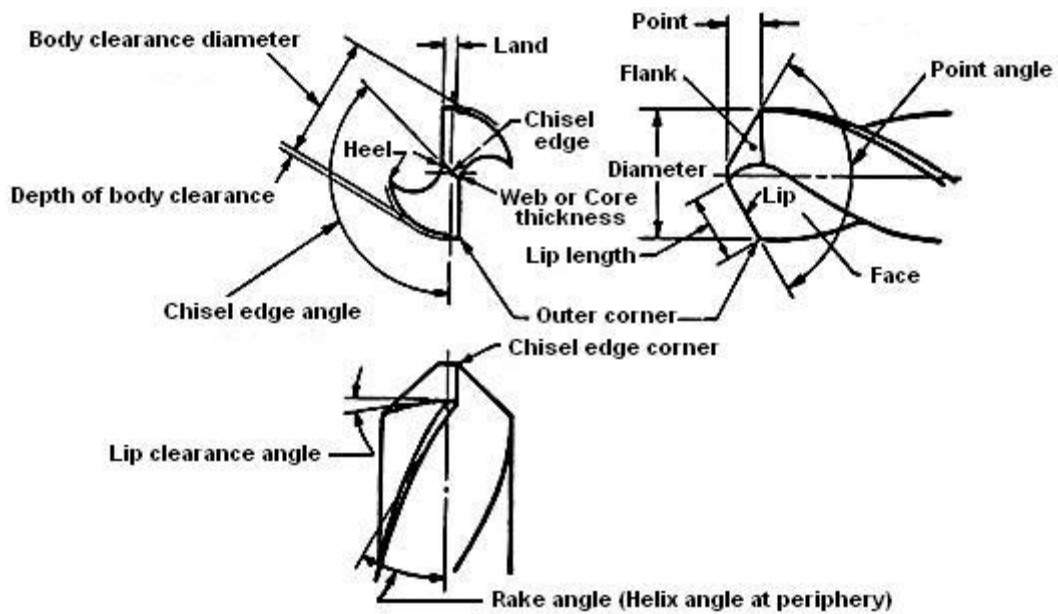

Fig. Twist drill nomenclature

Face: The portion of the flute surface adjacent to the lip on which the chip impinges as it is cut from the work.

Flank: That surface on a drill point which extends behind the lip to the following flute.

Flutes: The groove in the body of the drill which provides lip.

The functions of the flutes are:

- ⇒ To form the cutting edges.
- ⇒ To allow the chips to escape.
- ⇒ To cause the chips to curl.
- ⇒ To permit the cutting fluid to reach the cutting edges.

Heel: The edge formed by the intersection of the flute surface and the body clearance.

Lands: The cylindrically ground surface on the leading edges of the drill flutes. The width of the land is measured at right angles to the flute helix.

Lip (cutting edge) The edge formed by the intersections of the flank and face.

The requirements of the drill lip are:

- ⇒ Both lips should be at the same angle of inclination (59°) with the drill axis.
- ⇒ Both lips should be of equal length.
- ⇒ Both lips should be provided with the correct clearance.

Neck: The diametrically undercut portion between the body and the shank of the drill. Diameter and other particulars of the drill are engraved at the neck.

Outer corner: The corner formed by the intersection of the flank and face.

Point: The sharpened end of the drill, which is shaped to produce lips, faces, flanks and chisel edge.

Shank: That part of the drill by which it is held and driven. The most common types of shank are the taper shank and the straight shank.

Tang: The flattened end of the taper shank intended to fit into a drift slot in the spindle, socket or drill holder. The tang ensures positive drive of the drill from the spindle.

Web: The central portion of the drill situated between the roots of the flutes and extending from the point toward the shank; the point end of the web or core forms the chisel edge.

Linear dimensions

Back taper (longitudinal clearance) It is the reduction in diameter of the drill from the point towards the shank. This permits all parts of the drill behind the point to clear and not rub against the sides of the hole being drilled. The taper varies from 1:4000 for small diameter drills to 1:700 for larger diameters.

Body clearance diameter: The diameter over the surface of the drill body which is situated behind the lands.

Depth of body clearance: The amount of radial reduction on each side to provide body clearance.

Diameter: The measurement across the cylindrical lands at the outer corners of the drill.

Flute length: The axial length from the extreme end of the point to the termination of the flute at the shank end of the body.

Lead of helix The distance measured parallel to the drill axis between the corresponding points on the leading edge of the flute in one complete turn of the flute.

Lip length: The minimum distance between the outer corner and the chisel edge corner of the lip.

Overall length: The length over the extreme ends of the point and the shank of the drill.

Web (core) taper: The increase in the web or core thickness from the point of the drill to the shank end of the flute. This increasing thickness gives additional rigidity to the drill and reduces the cutting pressure at the point end.

Web thickness: The minimum dimension of the web or core measured at the point end of the drill.

DRILL ANGLES

The obtuse angle included between the chisel edge and the lip as viewed from the end of the drill.

Helix angle or rake angle: This is the angle formed by the leading edge of the land with a plane having the axis of the drill.

Point angle: This is the angle included between the two lips.

Lip clearance angle: The angle formed by the flank and a plane at right angles to the drill axis.

14. Sketch the following operations performed in drilling machine.

1. Drilling 2. Reaming 3. Boring 4. Counter boring 5. Counter sinking 6. Tapping (April/May 2010 & 12)

Drilling machines are generally or mainly used to originate through or blind straight cylindrical holes in solid rigid bodies and/or enlarge (coaxially) existing holes:

- ⇒ Of different diameters up to 40 mm.
- ⇒ Of varying length depending upon the requirement and the diameter of the drill.
- ⇒ In different materials excepting very hard or very soft materials like rubber, polythene etc.
- ⇒ Originating stepped cylindrical holes of different diameter and depth.
- ⇒ Making rectangular section slots by using slot drills having 3 or 4 flutes and 180^0 cone angle.
- ⇒ Boring, after drilling, for accuracy and finish or prior to reaming
- ⇒ Counter boring, countersinking, chamfering or combination using suitable tools.
- ⇒ Spot facing by flat end tools.
- ⇒ Trepanning for making large through holes and or getting cylindrical solid core.

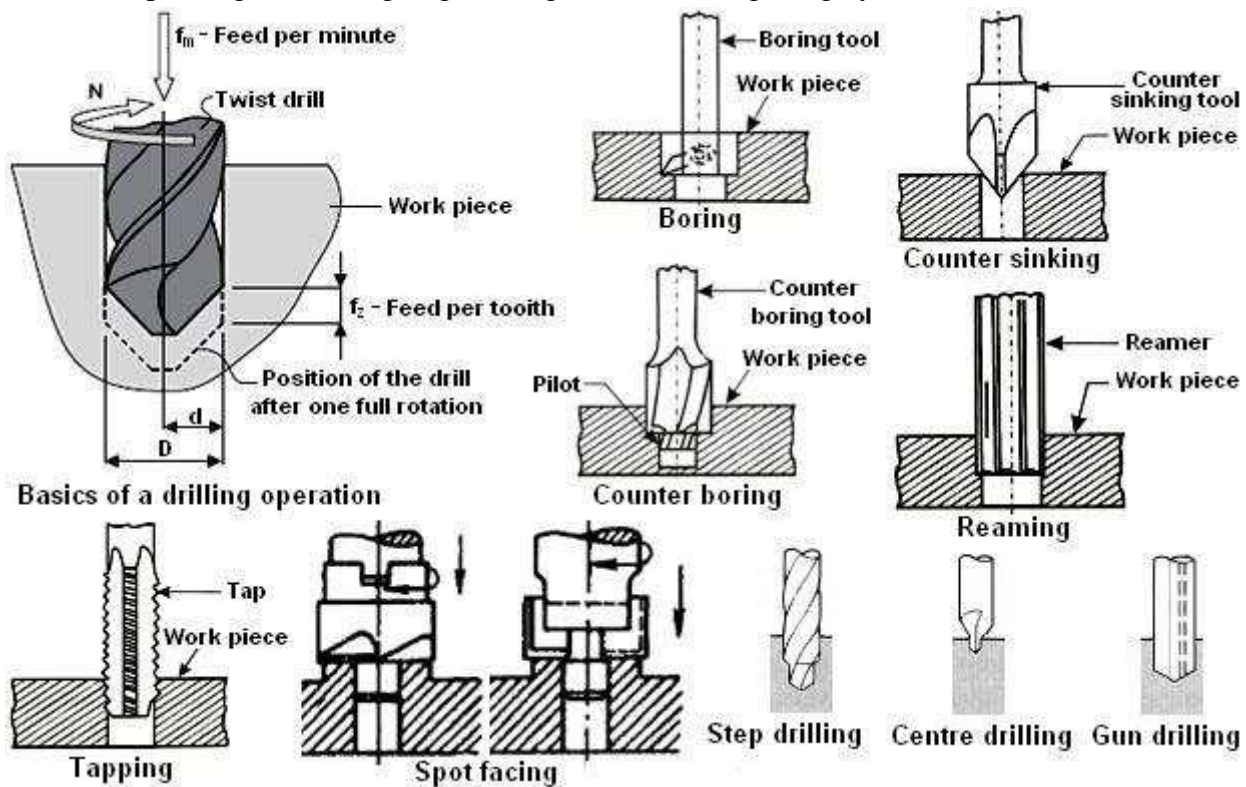

Fig. Different operations performed in a drilling machine

15. Write short notes on reaming operation. (Nov/Dec 2008 & April/May 2014)

Reaming is an operation of finishing a hole previously drilled to give a good surface finish and an accurate dimension. A reamer is a multi-tooth cutter which rotates and moves axially into the hole. The reamer removes relatively small amount of material. Generally the reamer follows the already existing hole and therefore will not be able to correct the hole misalignment.

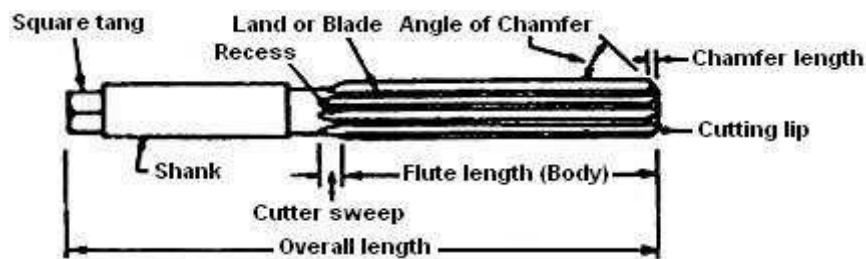
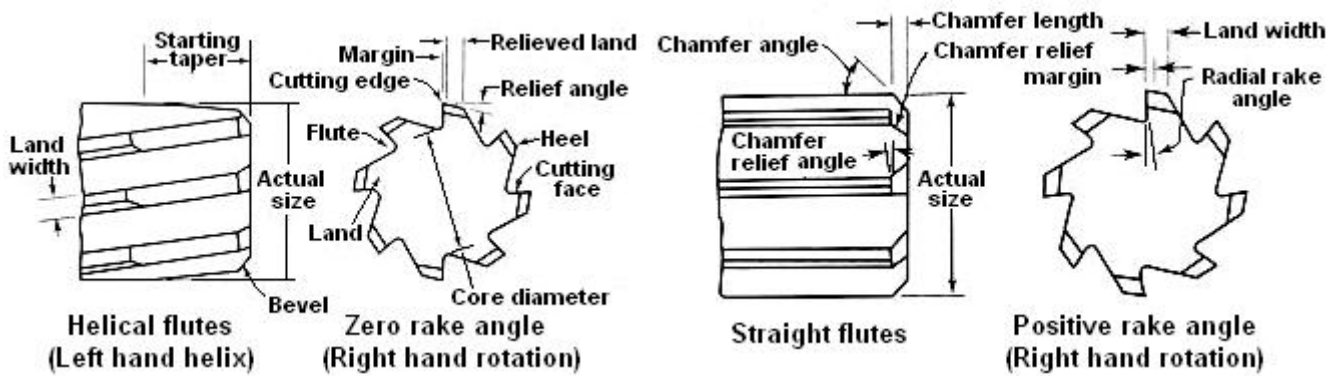

Fig. Elements of a reamer

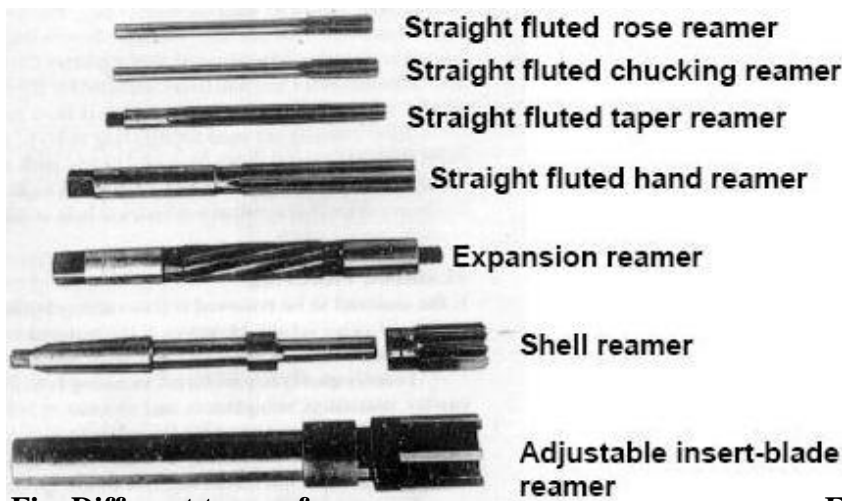

Fig. Different types of reamers

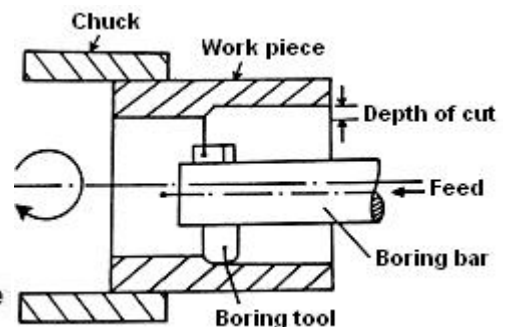

Fig. Principle of boring operation

16. Write short notes on boring machine. (Nov/ Dec 2008)

Boring is an operation of enlarging and locating previously drilled holes with a single point cutting tool. The machine used for this purpose is called boring machine. The boring machine is one of the most versatile machine tools used to bore holes in large and heavy parts such as engine frames, steam engine cylinders, machine housings etc. Drilling, milling and facing operations also can be performed in this machine.

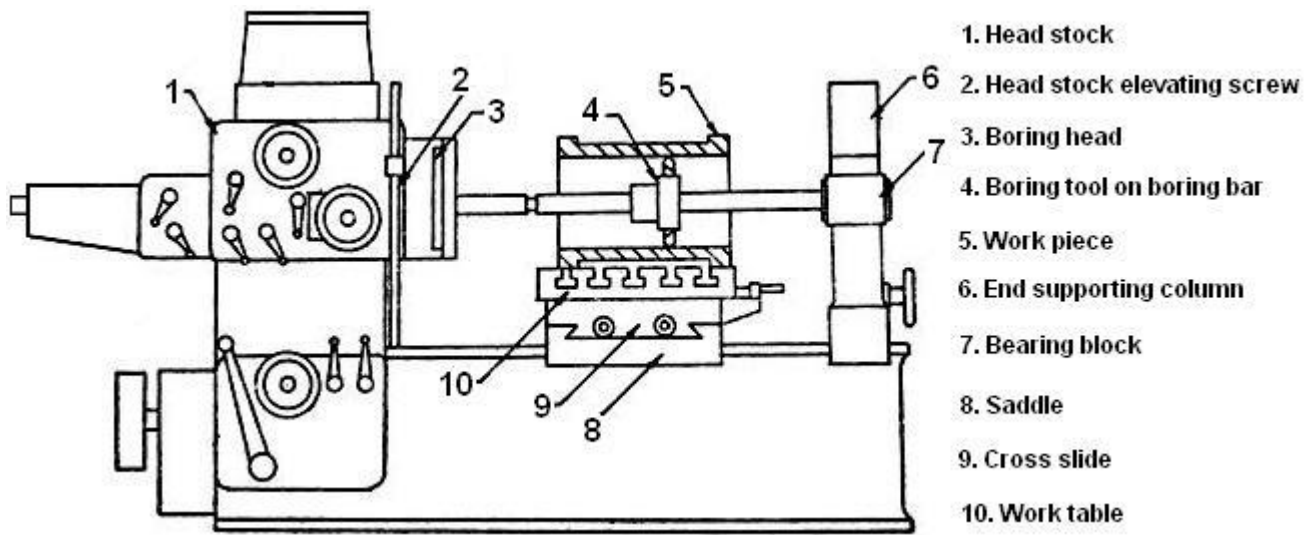

Fig. Basic configuration of a horizontal boring machine

Horizontal boring machines

- ❖ In horizontal boring machine, the tool revolves and the work is stationary. A horizontal boring machine can perform boring, reaming, turning, threading, facing, milling, grooving, recessing and many other operations with suitable tools.
- ❖ Work pieces which are heavy, irregular, unsymmetrical or bulky can be conveniently held and machined. This machine has two vertical columns. A headstock slides up and down in one column. It may be adjusted to any desired height and clamped.
- ❖ The headstock holds the cutting tool. The cutting tool revolves in the headstock in horizontal axis. A sliding type bearing block is provided in the other vertical column.
- ❖ It is used to support the boring bar. The work piece is mounted on the table and is clamped with ordinary strap clamps, T-slot bolts and nuts, or it is held in a special fixture if so required.
- ❖ Various types of rotary and universal swiveling attachments can be installed on the horizontal boring machines table to bore holes at various angles in horizontal and vertical planes.

Types of horizontal boring machine

Different types of horizontal boring machines have been designed to suit different purposes. They are:

1. Table type horizontal boring machine

The work is held stationary on a coordinate work table having in and out as well as back and forth movements that is perpendicular and parallel to the spindle axis. The spindle carrying the tool can be fed axially. Alternatively, the table travels parallel to the spindle axis (longitudinal feed). This method of boring with longitudinal feed of the table is employed when holes are of considerable length and being bending of the boring bar is possible.

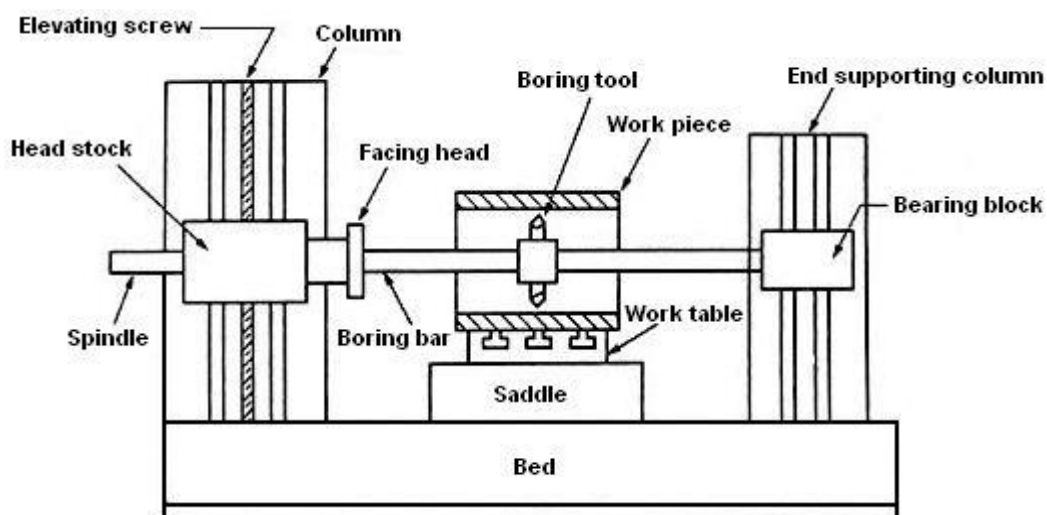

Fig. Table type horizontal boring machine

2. Planer type horizontal boring machine

This machine is similar to the table type horizontal boring machine except that the work table has only in and out movements that is perpendicular to the spindle axis. Other features and applications of this machine are similar to the table type horizontal boring machine. This type of machine is suitable for supporting a long work.

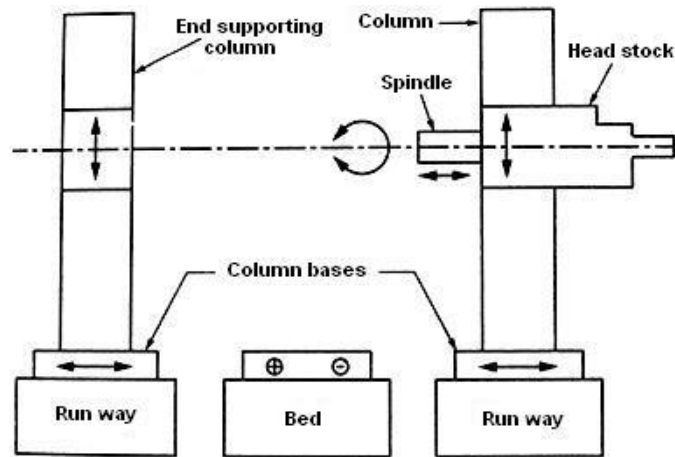

Fig. Planer type horizontal boring machine

3. Floor type horizontal boring machine

There is no work table and the job is mounted on a stationary T-slotted floor plate. This design is used when large and heavy jobs cannot be mounted and adjusted on the work table. Horizontal movement perpendicular to the spindle axis is obtained by traversing the column carrying the head stock, on guide ways.

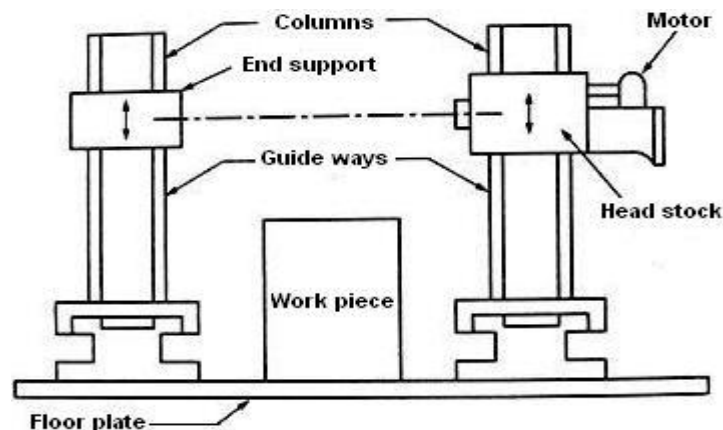

Fig. Floor type horizontal boring machine

4 Multiple head type horizontal boring machine

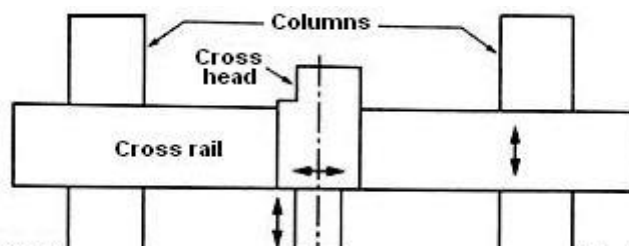

Fig. Multiple head type horizontal boring machine

The machine resembles a double housing planer or a Plano-miller and is used for boring holes of large diameter in mass production. The machine may have two, three or four headstocks. This type of machine may be used both as a horizontal and vertical machine

17. With neat sketches, explain the working of Vertical boring machines. (April/May 2004 & April/May 2013)

- ❖ For convenience, parts whose length or height is less than the diameter are machined on vertical boring machines.
- ❖ The typical works are: Large gear blanks, locomotive and rolling stock tires, fly wheels, large flanges, steam and water turbine castings etc.
- ❖ On a vertical boring machine, the work is fastened on a horizontal revolving table, and the cutting tool(s) which are stationary, advance vertically into it as the table revolves.
- ❖ There are two types of vertical boring machine: Single column vertical boring machine and double column vertical boring machine. The single column vertical boring machine looks like a drilling machine or a knee type vertical milling machine.
- ❖ Guide ways are employed on the column to support the spindle head in the vertical direction. The work is accommodated on the horizontal revolving table at the front of the machine.
- ❖ The circular work can be clamped on to the table with the help of jaw chucks whereas the T-slots can be used with bolts and clamps for setting up and holding irregular work.
- ❖ A horizontal cross rail is carried on vertical slide ways and carries the tool holder slide(s). On machines designed for working on large batches of identical parts, a single slide with turret may be employed.

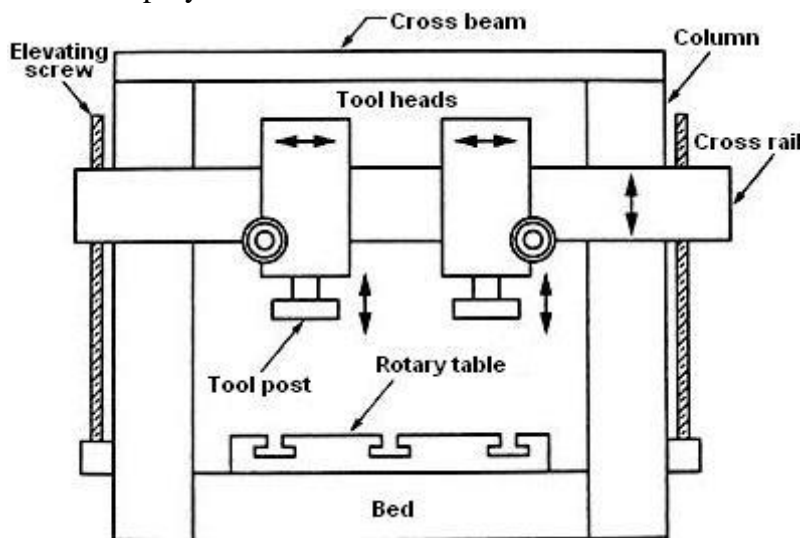

Fig. Double column vertical boring machine

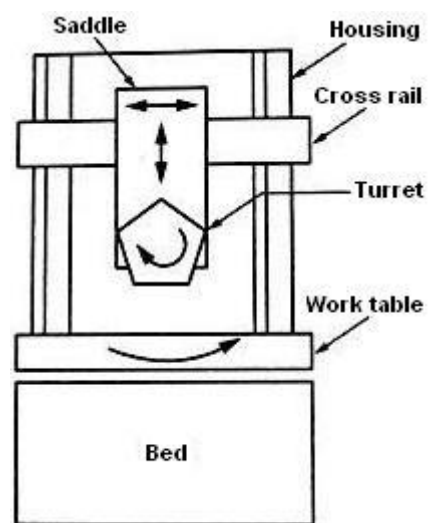

Fig. Turret boring machine

18. With neat sketches, explain the working of a Jig boring machine. (April/May 2004 & April/May 2013)

- ❖ It is very precise vertical type boring machine. The spindle and spindle bearings are constructed with very high precision. The table can be moved precisely in two mutually perpendicular directions in a plane normal to the spindle axis.
- ❖ The coordinate method for locating holes is employed. Holes can be located to within tolerances of 0.0025 mm. Jig boring machines are relatively costlier. Hence, they are found only in the large machine shops, where a sufficient amount of accurate hole locating is done.
- ❖ Jig boring machines are basically designed for use in the making jigs, fixtures and other special tooling.
- ❖ A boring tool consists of a single point cutting tool (boring bit) held in a tool holder known as boring bar. The boring bit is held in a cross hole at the end of the boring bar. The boring bit is adjusted and held in position with the help of set screws.
- ❖ The material of the boring bit can be: Solid HSS, solid carbide, brazed carbide, disposable carbide tips or diamond tips. Boring tools are of two types: fixed type and rotating type.

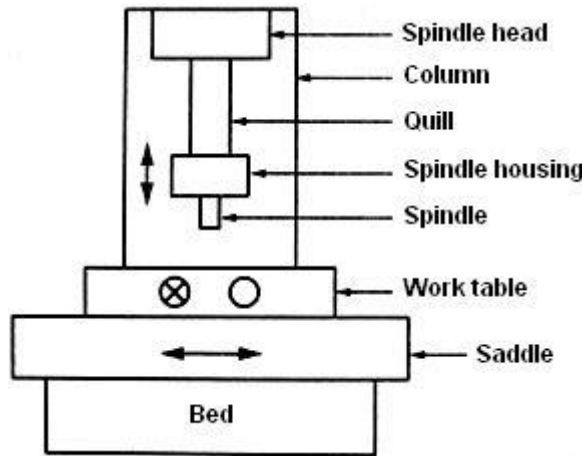

Fig. Block diagram of a jig boring machine

- ❖ Fixed type boring tools are used on working rotating machines such as lathes, whereas rotating type boring tools are used on tool rotating machines such as drilling machines, milling machines and boring machines.

20. Explain tapping process.

Tapping is the faster way of producing internal threads. A tap is a multi-fluted cutting tool with cutting edges on each blade resembling the shape of threads to be cut. A tap is used after carrying out the pre drilling operation corresponding to the required size.

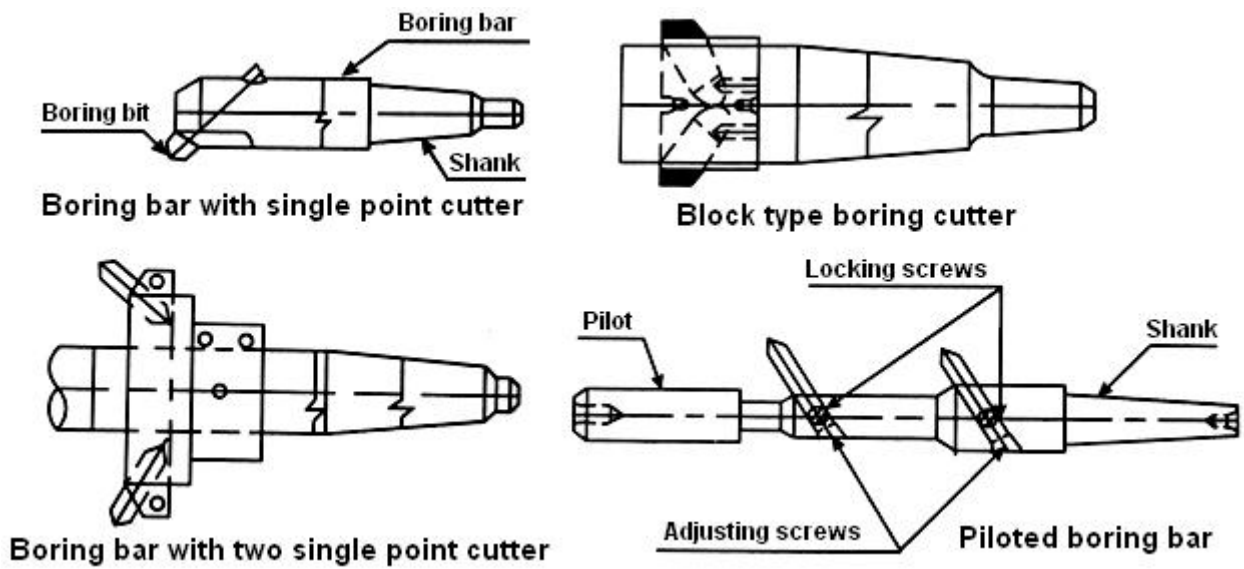

Fig. Different types of boring tools (bars)

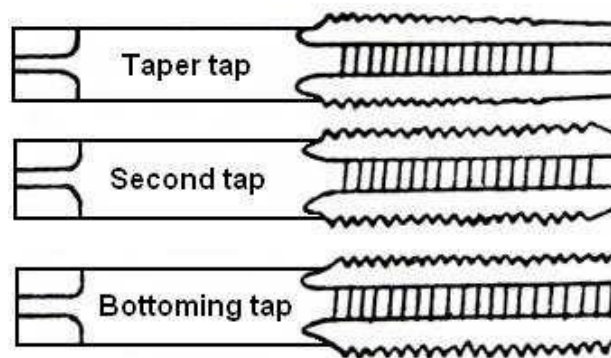

Fig. Hand (solid) taps

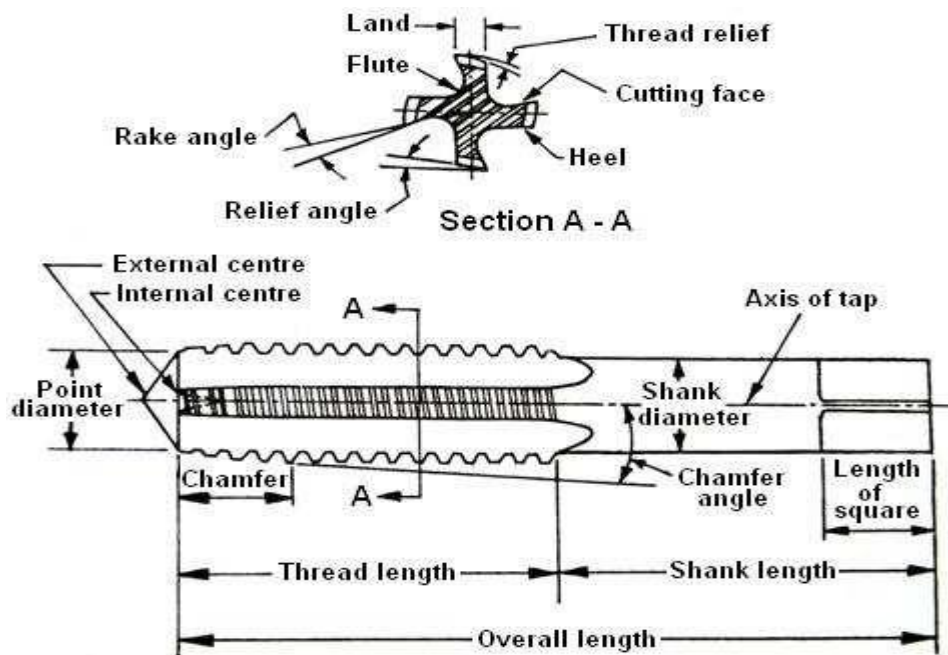

Fig. Elements of a solid tap

19. Describe the horizontal knee type milling machine with a suitable sketch. (Anna Univ. June 06,, Dec 10 ,,May 13).

This is the most commonly used machine in view of its flexibility and easier setup. In such small and medium duty machines the table with work travels above the saddle in horizontal direction (X axis) (left and right). The saddle with table moves on the slide ways provided on the knee in transverse direction (Y axis) (front and back). The knee with saddle and table moves on a dovetail guide ways provided on the column in vertical direction (Z axis) (up and down).

1. Hand milling machine

This is the simplest form of milling machine where even the table feed is also given manually. The cutter is mounted on a horizontal arbor. This is suitable for light and simple milling operations such as machining slots, grooves and keyways.

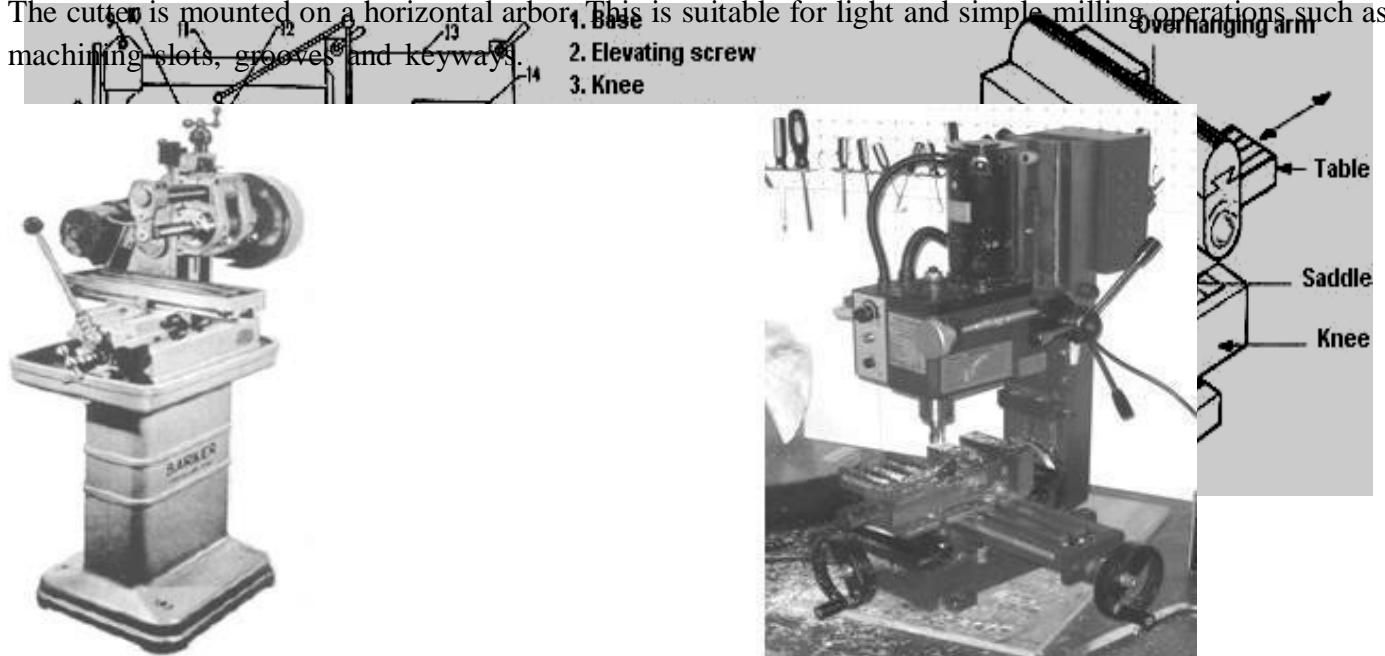

Fig. (a) Horizontal hand milling machine

Fig. (b) Vertical hand milling machine

2. Plain or horizontal milling machine

This non-automatic general purpose milling machine of small to medium size possesses a single horizontal axis milling arbor. The work table can be linearly fed along three axes (X, Y, and Z) only. The table may be fed by hand or power. These machines are most widely used for piece or batch production of jobs of relatively simple design and geometry.

Fig. Plain or horizontal milling machine

20. Describe the universal and omniversal type milling machine with a suitable sketch.

Universal milling machine

- ❖ It is so named because it may be adapted to a very wide range of milling operations. It can be distinguished from a plain milling machine in that the table of a universal milling machine is mounted on a circular swiveling base which has degree graduations, and the table can be swiveled to any angle up to 45° on either side of the normal position.
- ❖ Thus in a universal milling machine, in addition to the three movements as incorporated in a plain milling machine, the table has a fourth movement when it is fed at an angle to the milling cutter.
- ❖ This additional feature enables it to perform helical milling operation which cannot be done on a plain milling machine unless a spiral milling attachment is used.
- ❖ The capacity of a universal milling machine is considerably increased by the use of special attachments such as dividing head or index head, vertical milling attachment, rotary attachment, slotting attachment, etc.
- ❖ The machine can produce spur, spiral, bevel gears, twist drills, reamers, milling cutters, etc. besides doing all conventional milling operations.

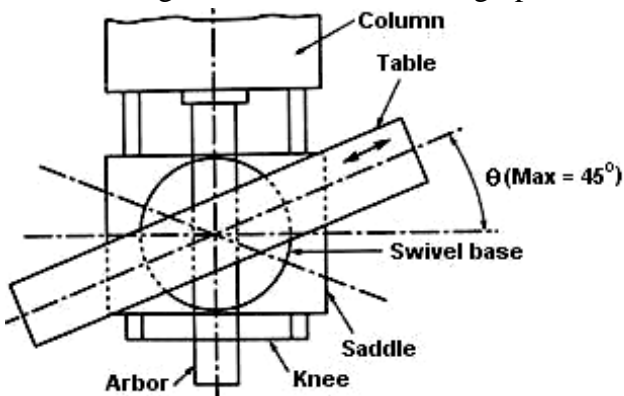

Fig. Universal milling machine

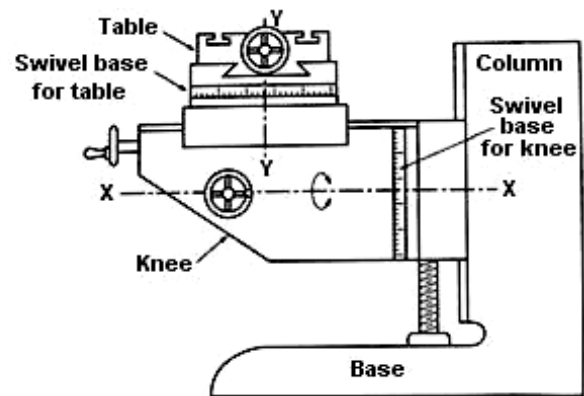

Fig. Omniversal milling machine4.

Omniversal milling machine

- ❖ In this machine, the table besides having all the movements of a universal milling machine can be tilted in a vertical plane by providing a swivel arrangement at the knee. Also the entire knee assembly is mounted in such a way that it may be fed in a longitudinal direction horizontally.
- ❖ The additional swiveling arrangement of the table enables it to machine taper spiral grooves in reamers, bevel gears, etc. It is essentially a tool room and experimental shop machine.

Vertical milling machine

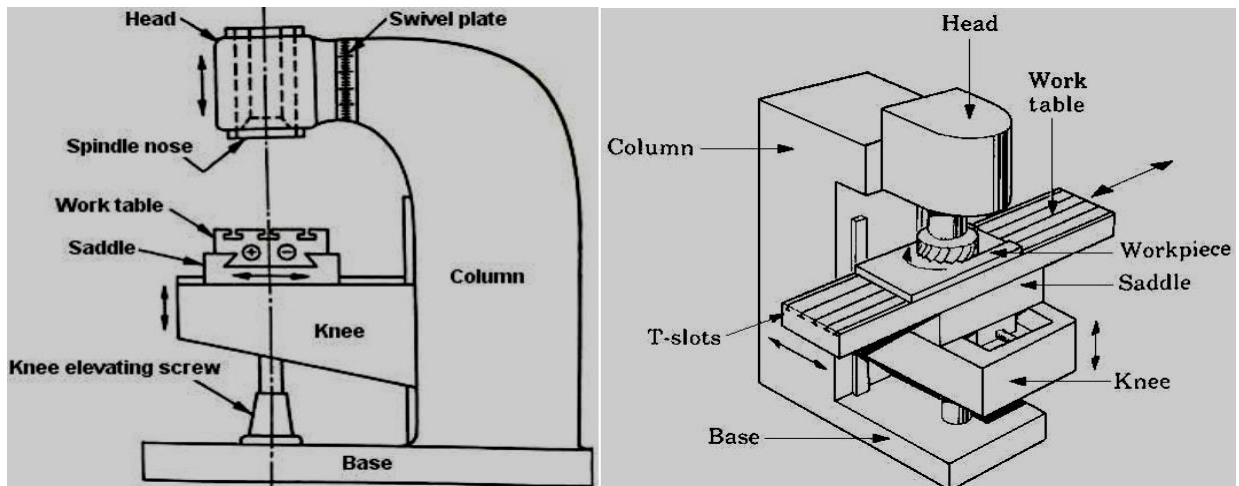

Fig. Vertical milling machine

- ❖ This machine is very similar to a horizontal milling machine. The only difference is the spindle is vertical. The work table may or may not have swiveling features.
- ❖ The spindle head may be swiveled at an angle, permitting the milling cutter to work on angular surfaces.
- ❖ In some machines, the spindle can also be adjusted up or down relative to the work piece. This machine works using end milling and face milling cutters. This machine is adapted for machining grooves, slots and flat surfaces

21. Describe the bed type milling machine with a suitable sketch

- ❖ The fixed bed type milling machines are comparatively large, heavy, and rigid and differ radically from column and knee type milling machines by the construction of its table mounting. The table is mounted directly on the guide ways of the fixed bed.
- ❖ The table movement is restricted to reciprocation at right angles to the spindle axis with no provision for cross or vertical adjustment.
- ❖ The cutter mounted on the spindle head may be moved vertically on the column, and the spindle may be adjusted horizontally to provide cross adjustment.
- ❖ The name simplex, duplex and triplex indicates that the machine is provided with single, double and triple spindle heads respectively. In a duplex machine, the spindle heads are arranged one on each side of the table. In triplex type the third spindle (vertical) is mounted on a cross rail.
- ❖ The usual feature of these machines is the automatic cycle of operation for feeding the table, which is repeated in a regular sequence.
- ❖ The feed cycle of the table includes the following: Start, rapid approach, slow feed for cutting, rapid traverse to the next work piece, quick return and stop.
- ❖ This automatic control of the machine enables it to be used with advantage in repetitive types of work.

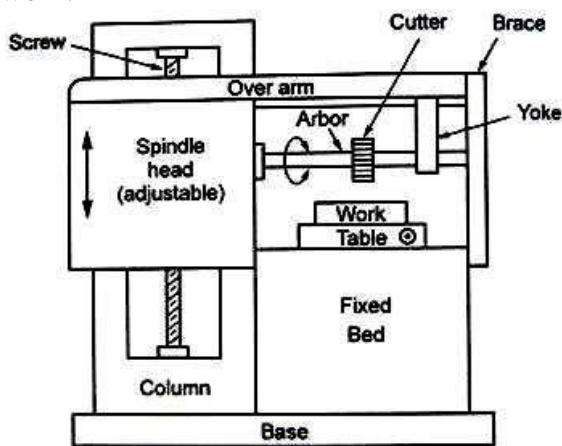

Fig. (a) Simplex milling machine

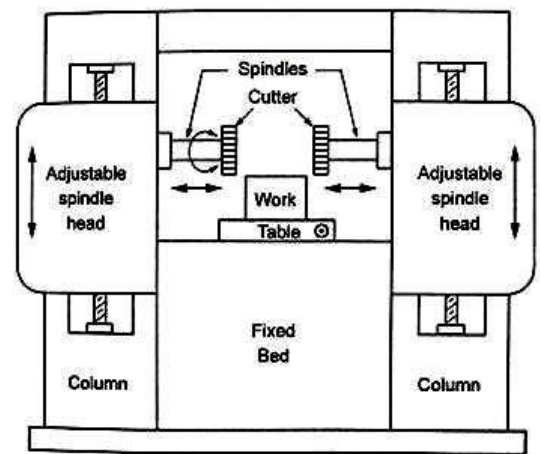

Fig. (b) Duplex milling machine

Planer type milling machine

This heavy duty large machine, called Plano-miller, look like planer where the single point tools are replaced by one or a number of milling heads. This is generally used for machining a number of longitudinal flat surfaces simultaneously, such as lathe beds, table and bed of planer etc. Modern Plano-millers are provided with high power driven spindles powered to the extent of 100 hp. and the rate of metal removal is tremendous. The use of this machine is limited to production work only and is considered ultimate in metal removing capacity.

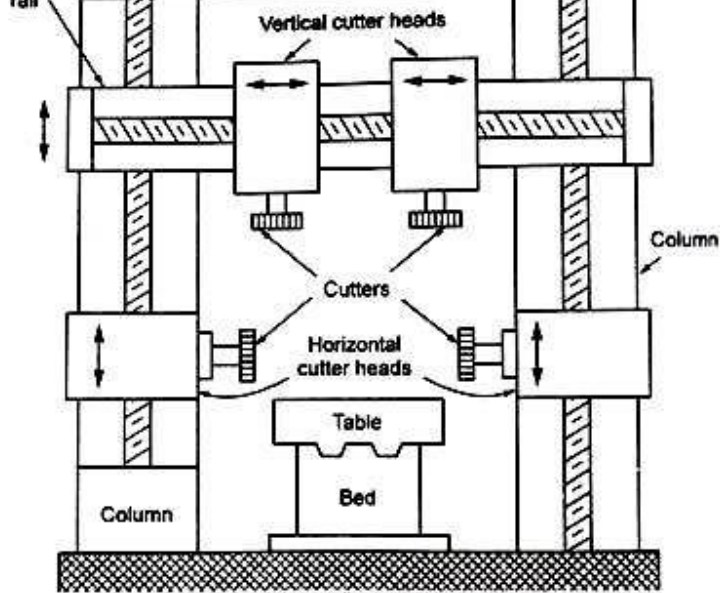

Fig. Planer type milling machine

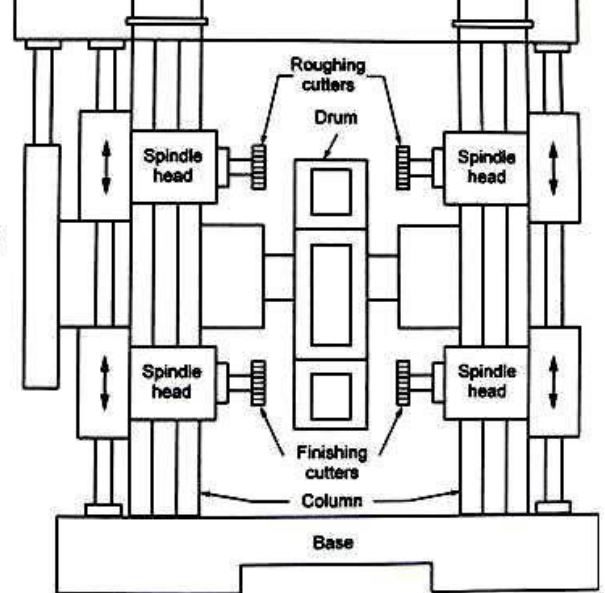

Fig. Drum type milling machine

SPECIAL TYPE MILLING MACHINES

1. Drum milling machine

These machines are of the continuous- operation type. They are mostly found in large-lot and mass production shops for production of large parts such as motor blocks, gear cases, and clutch housings. Two flat surfaces of the work piece can be milled simultaneously.

A square drum (sometimes it may be a regular pentagon or hexagon), is mounted on a shaft passing through the frame. Parts are carried in fixtures mounted on the drum faces. The drum rotates continuously in a horizontal axis, carrying the parts between face milling cutters. The milling cutters are mounted on three or four spindle heads and rotates in a horizontal axis.

2. Rotary table milling machine

The construction of this machine is the modification of a vertical milling machine and is adapted for machining flat surfaces. Such open or closed ended high production milling machines possess one large rotary work table rotates about a vertical axis and one or two vertical spindles. The positions of the work piece(s) and the milling head are adjusted according to the size and shape of the work piece. A continuous loading and unloading of work pieces may be carried out by the operator while the milling is in progress.

3. Profile milling machine

This machine duplicates the full size of the template attached to the machine. This is practically a vertical milling machine of bed type in which the spindle can be adjusted vertically and the cutter head horizontally across the table. The movement of the cutter is regulated by a hardened guide pin. The pin is held against and follows outline or profile of a template mounted on the table at the side of the work piece. The longitudinal movement of the table and crosswise movement of the cutter head follow the movements of the guide pin on the template.

4. Planetary milling machine

In this machine, the work is held stationary while the revolving cutter(s) move in a planetary path to finish a cylindrical surface on the work either internally or externally or simultaneously. This machine is particularly adapted, for milling internal or external threads of different pitches.

5. Major parts of a column and knee type milling machine

The major parts are:

Base: It is accurately machined on its top and bottom surface and serves as a foundation member for all other parts. It carries the column at its one end. In some machines, the base is hollow and serves as a reservoir for cutting fluid.

Column: It is the main supporting frame mounted vertically on the base. The column is box shaped, heavily ribbed inside and houses all the driving mechanisms for the spindle and table feed. The front vertical face of the column is accurately machined and is provided with dovetail guide ways for supporting the knee. The top of the column is finished to hold an over arm that extends outward at the front of the machine.

Knee: It slides up and down on the vertical guide ways of the column face. The adjustment of height is effected by an elevating screw mounted on the base that also supports the knee.

The knee houses the feed mechanism of the table, and different controls to operate it. The top face of the knee forms a slide ways for the saddle to provide cross travel of the table.

Table: The table rests on ways on the saddle and travels longitudinally. The top of the table is accurately finished and T-slots are provided for clamping the work and other fixtures on it. A lead screw under the table engages a nut on the saddle to move the table horizontally by hand or power. The longitudinal travel of the table may be limited by fixing trip dogs on the side of the table. In universal machines, the table may also be swiveled horizontally.

Overhanging arm: The overhanging arm that is mounted on the top of the column extends beyond the column face and serves as a bearing support for the other end of the arbor. The arm is adjustable so that the bearing support may be provided nearest to the cutter.

Front brace: The front brace is an extra support that is fitted between the knee and the over arm to ensure further rigidity to the arbor and the knee. The front brace is slotted to allow for the adjustment of the height of the knee relative to the over arm.

Spindle: The spindle of the machine is located in the upper part of the column and receives power from the motor through belts, gears, clutches and transmits it to the arbor. The front end of the spindle just projects from the column face and is provided with a tapered hole into which various cutting tools and arbors may be inserted. The accuracy in metal machining by the cutter depends primarily on the accuracy, strength, and rigidity of the spindle.

Arbor: It may be considered as an extension of the machine spindle on which milling cutters are securely mounted and rotated. The arbors are made with taper shanks for proper alignment with the machine spindles having taper holes at their nose. The arbor may be supported at the farthest end from the overhanging arm or may be of cantilever type which is called stub arbor.

Working principle of a column and knee type milling machine

- ❖ The kinematic system comprising of several mechanisms enables transmission of motion and power from the motor to the cutting tool for its rotation at varying speeds and to the work table for its slow feed motions along X, Y and Z directions.
- ❖ The milling cutter mounted on the horizontal milling arbor, receives its rotary motion at different speeds from the main motor through the speed gear box.

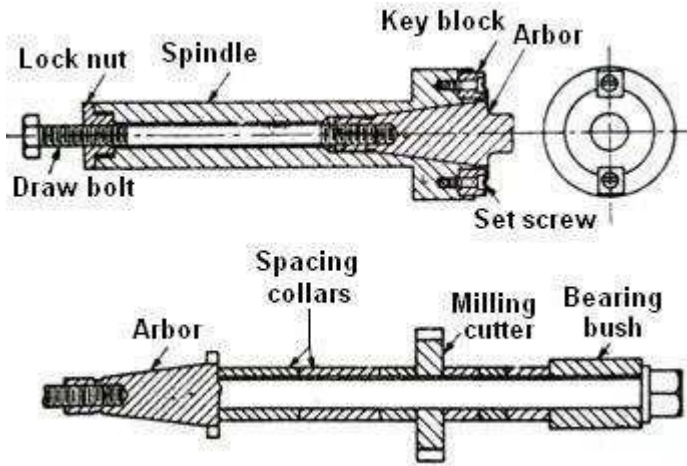

Fig. Arbor assembly

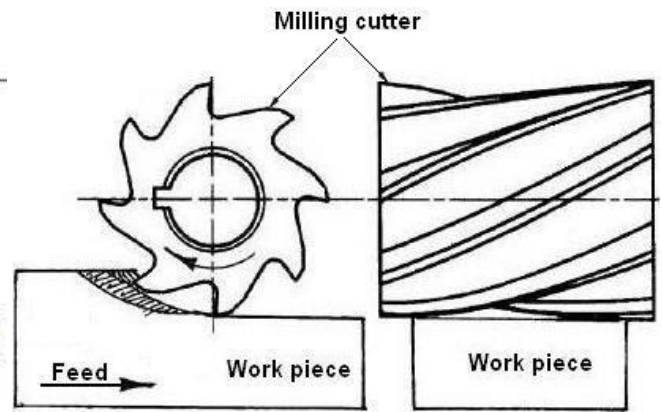

Fig. Principle of producing flat surface

- ❖ The feeds of the work piece can be given by manually or automatically by rotating the respective wheels by hand or by power. The work piece is clamped on the work table by a work holding device.
- ❖ Then the work piece is fed against the rotating multipoint cutter to remove the excess material at a very fast rate.

22. Explain with neat sketches in work holding devices used in milling.

It is necessary that the work piece should be properly and securely held on the milling machine table for effective machining operations. The work piece may be supported on the milling machine table by using any one of the following work holding devices depending upon the geometry of the work piece and nature of the operation to be performed.

- ❖ T-bolts and clamps.
- ❖ Angle plate.
- ❖ V-blocks.
- ❖ Vises.
- ❖ Special fixtures.
- ❖ Dividing heads.

T-bolts and clamps Bulky work pieces of irregular shapes are clamped directly on the milling machine table by using T-bolts and clamps. Different designs of clamps are used for different patterns of work.

Angle plate: Sometimes a tilting type angle plate in which one face can be adjusted relative to another face for milling at a required angle is also used.

V-blocks: This is used for holding shafts on the table in which keyways, slots and flats are to be milled.

Vises: Vises are the most common appliances for holding work on milling machine table due to its quick loading and unloading arrangement.

Special fixtures: The fixtures are special devices designed to hold work for specific operations more efficiently than standard work holding devices.

Fixtures are especially useful when large numbers of identical parts are being produced. By using fixtures loading, locating, clamping and unloading time is greatly minimized.

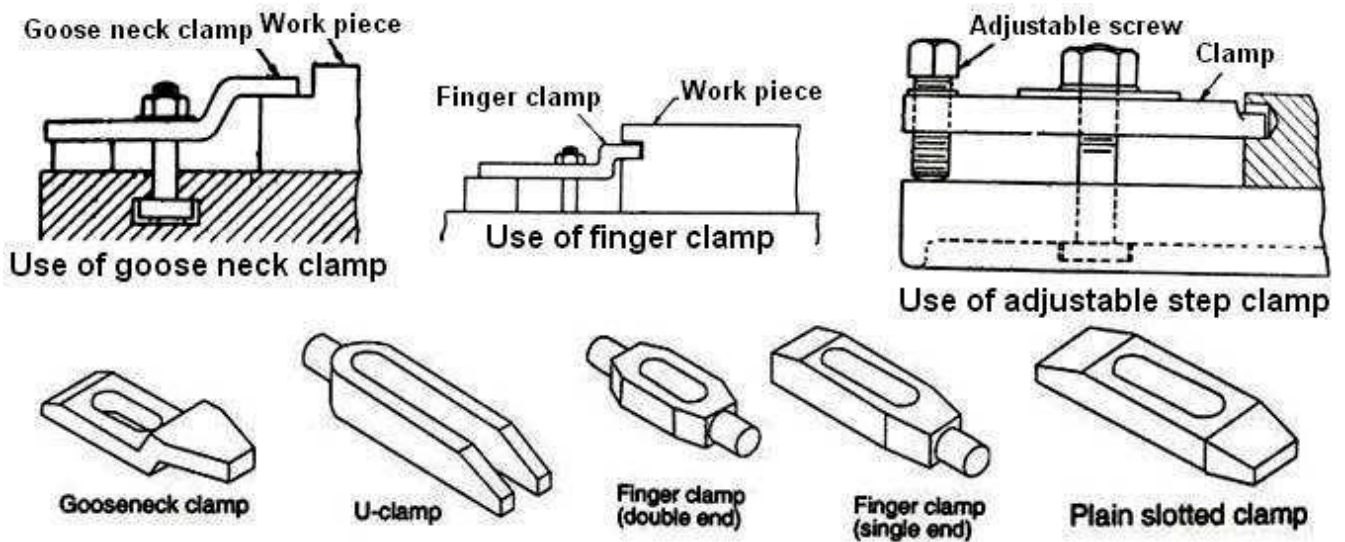

Fig. Different types of clamps

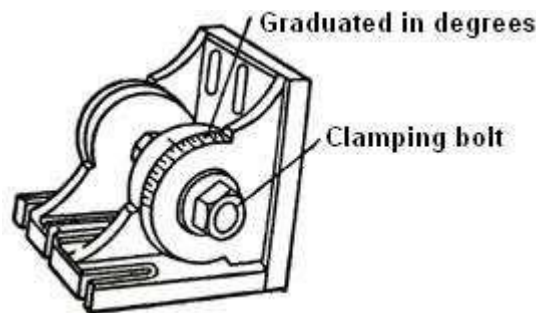

Fig. Tilting type angle plate

23. Explain the indexing mechanism of a dividing head on milling machine. (Anna Univ..May 14).

Describe the working mechanism of a universal dividing head, with neat diagrams. (Anna Univ..Apr 04 & June 06).

Explain the simple indexing, compound indexing and differential indexing with suitable examples. (Anna Univ. Dec 07)

- ❖ It is a special work holding device used in a milling machine. Dividing head can also be considered as a milling machine attachment.
- ❖ An important function and use of milling machines is for cutting slots, grooves etc. which are to be equally spaced around the circumference of a blank, for example, gear cutting, ratchet wheels, milling cutter blanks, reamers etc.
- ❖ This necessitates holding of the blank (work piece) and rotating it the exact amount for each groove or slot to be cut. This process is known as “indexing”. The work piece is rotated by turning the index crank by means of handle.

- ❖ Since the gear ratio of worm and worm wheel is 40:1, it takes 40 turns of the crank to rotate the spindle and hence the work piece through one complete revolution. Thus one turn of the crank rotates the work piece through $1/40^{\text{th}}$ of a turn.

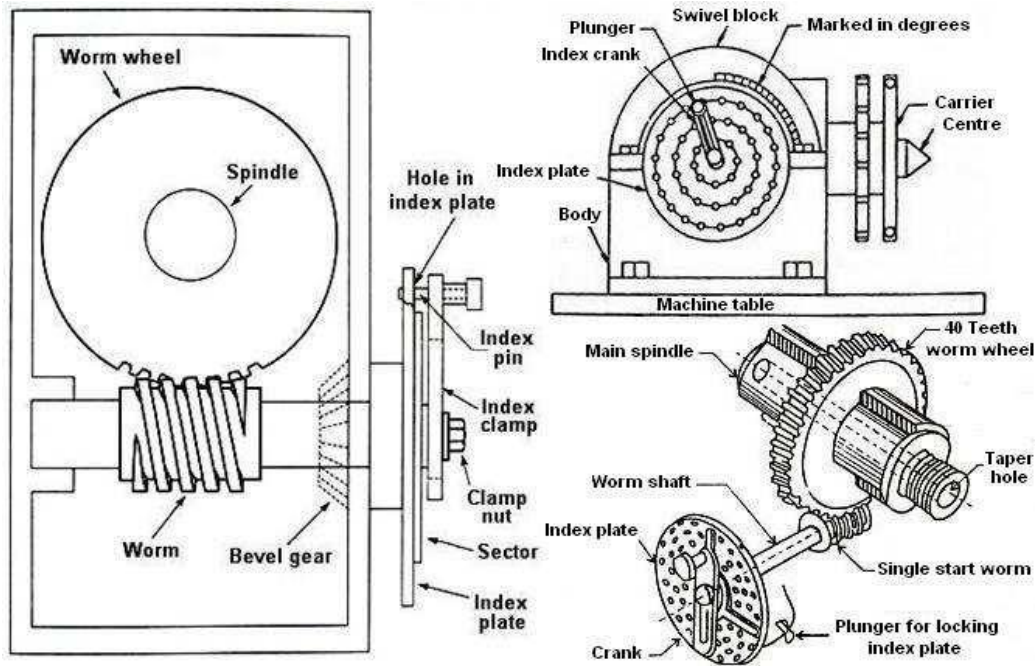

Fig. Dividing head

Index plate: It helps to accomplish indexing (dividing) of the work into equal divisions. It is a circular plate approximately 6 mm thick, with holes (equally spaced) arranged in concentric circles. The space between two subsequent holes is same for each circle; however it is different for different circles. A plate can have through holes or blind holes on its faces.

For a plain dividing head, the index plate is fixed to the body of the dividing head while in the case of universal dividing head it is mounted on the sleeve of the worm shaft. Various manufactures in U.S.A. and other countries have produced index plates with different number of hole circles.

For example *The index plates available with the Brown and Sharpe milling machines are:*

- Plate No. 1 - 15, 16, 17, 18, 19, 20
- Plate No. 2 - 21, 23, 27, 29, 31, 33
- Plate No. 3 - 37, 39, 41, 43, 47, 49

The index plate used on the Cincinnati and Parkinson milling machine is:

- Obverse (A) - 24, 25, 28, 30, 34, 37, 38, 39, 41, 42, 43
- Reverse (B) - 46, 47, 49, 51, 53, 54, 57, 58, 59, 62, and 66

- Index plates made in Germany are:*
- Plate No. 1 - 23, 25, 28, 31, 39, 43, 51, 59
 - Plate No. 2 - 16, 27, 30, 33, 41, 47, 53, 61
 - Plate No. 3 - 22, 24, 29, 36, 37, 49, 57, 63

The high number index plates are used to increase the indexing capacity. These index plates are similar to those discussed earlier except that these contain very large number of holes. Cincinnati Milling Machine Co. U.S.A. produces a set of three plates with holes on both sides of the plate as given below:

<i>Plate No. 1</i>	Obverse (A) -	30, 48, 69, 91, 99, 117, 129, 147, 171, 177, 189
	Reverse (B) -	36, 67, 81, 97, 111, 127, 141, 157, 169, 183, and 194
<i>Plate No 2</i>	Obverse (A) -	34, 46, 79, 93, 109, 123, 139, 153, 167, 181, 197
	Reverse (B) -	32, 44, 77, 89, 107, 121, 137, 151, 163, 179, and 193
<i>Plate No. 3</i>	Obverse (A) -	26, 42, 73, 87, 103, 119, 133, 149, 161, 175, 191
	Reverse (B) -	28, 38, 71, 83, 101, 113, 131, 143, 159, 173, and 187

It is important to note that there is no standard followed internationally in this regard. The number of plates supplied varies with different manufacturers. However this does not change the principle of indexing. It should be put up with in mind that larger the number of plates, and more the hole circles and holes wider is the range of indexing and accuracy.

Types of dividing heads: The various dividing heads used with milling machines are:

- 1. Plain indexing head:** A plain dividing head has a fixed spindle axis and the spindle rotates only about a horizontal axis.
- 2. Universal indexing head:** In this, the spindle can be rotated at different angles in the vertical plane from horizontal to vertical. This head performs the following functions: indexes the work piece, imparts a continuous rotary motion to the work piece for milling helical grooves (flutes of drills, reamers, milling cutters etc.) and setting the work piece in a given inclined position with reference to the table.
- 3. Optical indexing head:** These models are used for high precision angular setting of the work piece with respect to the cutter. For reading the angles, an optical system is built into the dividing head.

Methods of indexing: The various methods of indexing are discussed below:

Direct indexing;

- ❖ In this, the index plate is directly mounted on the dividing head spindle. The intermediate use of worm and worm wheel is avoided.
- ❖ For indexing, the index pin is pulled out on a hole, the work and the index plate are rotated the desired number of holes and the pin is engaged. Both plain and universal heads can be used in this manner.
- ❖ Direct indexing is the most rapid method of indexing, but fractions of a complete turn of the spindle are limited to those available with the index plate. With a standard indexing plate having 24 holes, all factors of 24 can be indexed, that is, the work can be divided into 2,3,4,6,8,12 and 24 parts.

Simple or plain indexing:

- ❖ In this, the index plate selected for the particular application, is fitted on the worm shaft and locked through a locking pin. To index the work through any required angle, the index crank pin is withdrawn from a hole in the index plate.
- ❖ The work piece is indexed through the required angle by turning the index crank through a calculated number of whole revolutions and holes on one of the hole circles, after which the index pin is relocated in the required hole. If the number of divisions on the job circumference (that is number of indexing) needed is z , then the number of turns (n) that the crank must be rotated for each indexing can be found from the formula: $n = \frac{z}{24}$ turns.

Example 1: Indexing 28 divisions.

This can be done as follows using any one of the Brown and Sharpe plates. One full rotation + 9 holes in 21 hole circle in plate No. 2.

One full rotation + 21 holes in 49 hole circle in plate No. 3.

Compound indexing

- ❖ When the available capacity of the index plates is not sufficient to do a given indexing, the compound indexing method can be used. First, the crank is moved in the usual fashion in the forward direction.
- ❖ Then a further motion is added or subtracted by rotating the index plate after locking the plate with the plunger. This is termed as compound indexing. For example, if the indexing is done by moving the crank by 5 holes in the 20 hole circle and then the index plate together with the crank is indexed back by a hole with the locking plunger registering in a 15 hole circle.

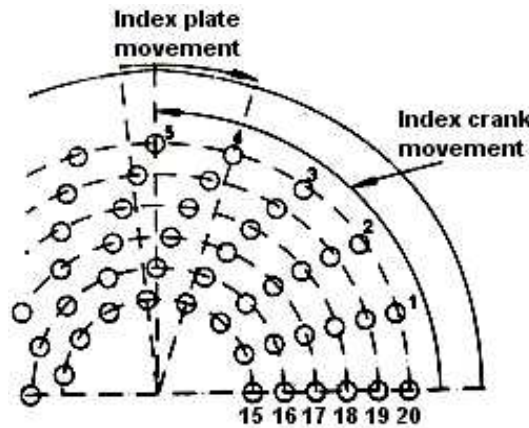

Fig. An example of compound indexing

Differential indexing

This is an automatic way to carry out the compound indexing method. In this the required division is obtained by a combination of two movements:

The movement of the index crank similar to the simple indexing.

The simultaneous movement of the index plate, when the crank is turned.

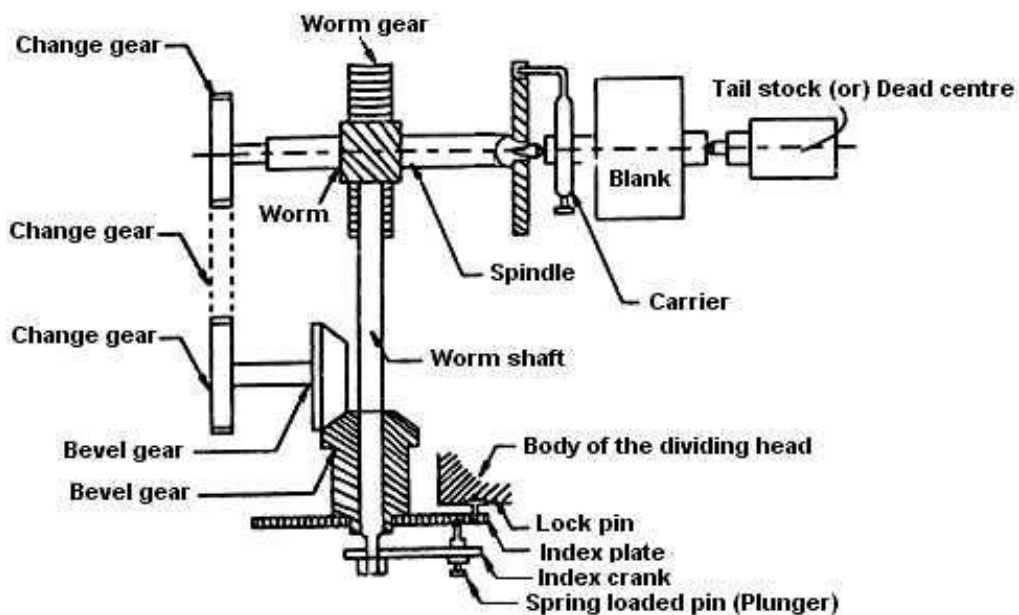

Fig. Arrangement for differential indexing

In differential indexing, the index plate is made free to rotate. A gear is connected to the back end of the dividing head spindle while another gear is mounted on a shaft and is connected to the shaft of the index plate through bevel gears. When the index crank is rotated, the motion is communicated to the work piece spindle. Since the work piece spindle is connected to the index plate through the intermediate gearing as explained above, the index plate will also start rotating.

- ❖ The procedure of calculation is explained with the following example.
- ❖ The change gear set available is 24 (2), 28, 32, 40, 44, 48, 56, 64, 72, 86 and 100.

Example 3: Obtain the indexing for 209 divisions.

The required indexing is 40/209 which cannot be obtained with any of the index plates available. Choose the nearest possible division. For example, the indexing decided is $40/200 = 4/20$

The actual indexing decided is 4 holes in a 20 hole circle. This indexing will be more than required. Ideally the workpiece should complete one revolution when the crank is moved through 209 turns at the above identified indexing. The actual motion generated when the crank is moved 209 times

Hence the index plate has to move in the reverse by this amount during the 209 turns to compensate for the larger indexing being done by the index crank.

Angular indexing

Sometimes it is desirable to carry out indexing using the actual angles rather than equal numbers along the periphery. Here, angular indexing would be useful. The procedure remains the same as in the previous cases, except that the angle will have to be first converted to equivalent divisions. Since 40 revolutions of the crank equals to a full rotation of the work piece, which means 360° , one revolution of the crank is equivalent to 9° . The formula to find the index crank movement is given below.

$$\begin{aligned} \text{Index crank movement} &= \text{Angular displacement of work (in degrees)} / 9 \\ &= \text{Angular displacement of work (in minutes)} / 540 \\ &= \text{Angular displacement of work (in seconds)} / 32400 \end{aligned}$$

Example 4: Calculate the indexing for $19^{\circ} 40'$.

$$19^{\circ} 40' = (19 \times 60) + 40 = 1140 + 40 = 118$$

This can be done as follows using the Brown and Sharpe plates. Two full rotations + 5 holes in 27 hole circle in plate No. 2.

CUTTER HOLDING DEVICES USED IN A MILLING MACHINE

There are several methods of holding and rotating milling cutters by the machine spindle depending on the different designs of the cutters. They are

1 Arbors

The cutters have a bore at the centre are mounted and keyed on a short shaft called arbor..

2 Collets

A milling machine collet is a form of sleeve bushing for reducing the size of the taper hole at the nose of the spindle so that an arbor or a milling cutter having a smaller shank than the spindle taper can be fitted into it.

3 Adapter

An adapter is a form of collet used on milling machine having standardized spindle end. Cutters having straight shanks are usually mounted on adapters. An adapter can be connected with the spindle by a draw bolt or it may be directly bolted to it.

4 Spring collets

Straight shank cutters are usually held on a special adapter called “spring collet” or “spring chuck”. The cutter shank is introduced in the cylindrical hole provided at the end of the adapter and then the nut is lightened. This causes the split jaws of the adapter to spring inside, and grip the shank firmly.

5 Bolted cutters

The face milling cutters of larger diameter having no shank are bolted directly on the nose of the spindle. For this purpose four bolt holes are provided on the body of the spindle. This arrangement of holding cutter ensures utmost rigidity.

6 Screwed on cutters

The small cutters having threaded holes at the centre are screwed on the threaded nose of an arbor which is mounted on the spindle in the usual manner.

SPECIAL ATTACHMENTS USED IN MILLING MACHINES

The attachments are intended to be fastened to or joined with one or more components of the milling machine for the purpose of enhancing the range, versatility, productivity and accuracy of operation. Some classes of milling machine attachments are used for positioning and driving the cutter by altering the cutter axis and speed, whereas other classes are used for positioning, holding and feeding the work along a specified geometric path. The following are the different attachments used on standard column and knee type horizontal milling machine.

1. Universal milling attachment

- ❖ For milling by solid end mill type and face milling cutters, separate vertical axis type milling machines are available.
- ❖ But horizontal arbor type milling machines can also be used for those operations to be done by end milling and smaller size face milling cutters by using the universal milling attachment.
- ❖ The rotation of the horizontal spindle is transmitted into rotation about vertical axis and also in any inclined direction by this attachment which thus extends the processing capabilities and application range of the milling machine.

2 Indexing head or dividing head

- ❖ This attachment is also considered as an accessory.

3. Rotary table

- ❖ This device may also be considered both accessory or attachment and is generally used in milling machines for both offline and online indexing / rotation of the work piece, clamped on it, about vertical axis.

4. Slotting attachment

- ❖ Such simple and low cost attachment is mounted on the horizontal spindle for producing keyways and contoured surface requiring linear travel of single point tool in milling machine where slotting machine and broaching machine are not available.
- ❖ The mechanism inside the attachment converts rotation of the spindle into reciprocation of the single point tool in vertical direction. The direction of the tool path can also be tilted by swiveling the circular base of the attachment body.

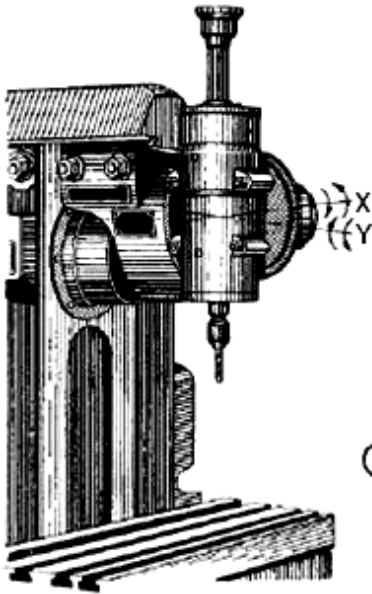

Fig. Universal milling attachment

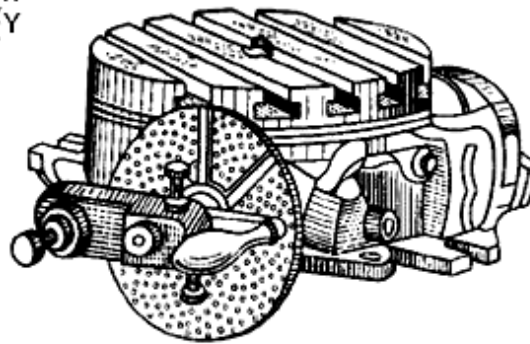

Fig. Rotary table

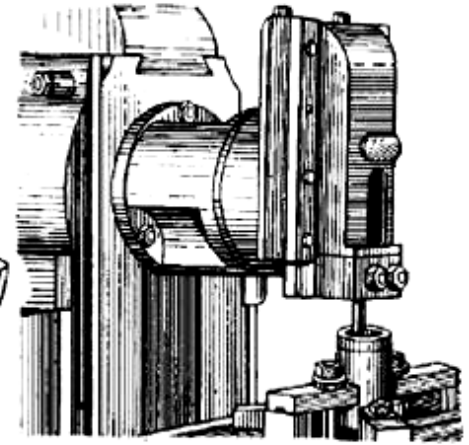

Fig. Slotting attachment

MILLING CUTTERS

Milling machines are mostly general purpose and have wide range various types and sizes of milling cutters.

A milling cutter is a multi-edged rotary cutting tool having the shape of a solid of revolution with cutting teeth arranged either on the periphery or on the end face or on both. Usually, the cutter is held in a fixed (but rotating) position and the work piece moves past the cutter during the machining operation.

1. Cutter materials

Intermittent cutting nature and usually complex geometry necessitate making the milling cutters mostly by HSS which is unique for high tensile and transverse rupture strength, fracture toughness and formability almost in all respects i.e. forging, rolling, powdering, welding, heat treatment, machining (in annealed condition) and grinding. Tougher grade cemented carbides are also used without or with coating, where feasible, for high productivity and product quality. In some cutters tungsten carbide teeth are brazed on the tips of the teeth or individually inserted and held in the body of the cutter by some mechanical means. Carbide tipped cutter is especially adapted to heavy cuts and increased cutting speeds. *The advantages of carbide tipped cutters (either solid or inserted blade type) are:*

- ❖ Their high production capacity.
- ❖ The high quality of the surfaces they produce.

2. Types of milling cutters

Many different kinds of milling cutters are used in milling machines. They are:

1 Slab or plain milling cutters: Straight or helical fluted

Plain milling cutters are hollow straight HSS cylinder of 40 to 80 mm outer diameter having 4 to 16 straight or helical equi-spaced flutes or cutting edges on the circumference. These are used in horizontal arbor to machine flat surfaces parallel to the axis of rotation of the spindle. Very wide plain milling cutters are termed as slab milling cutters.

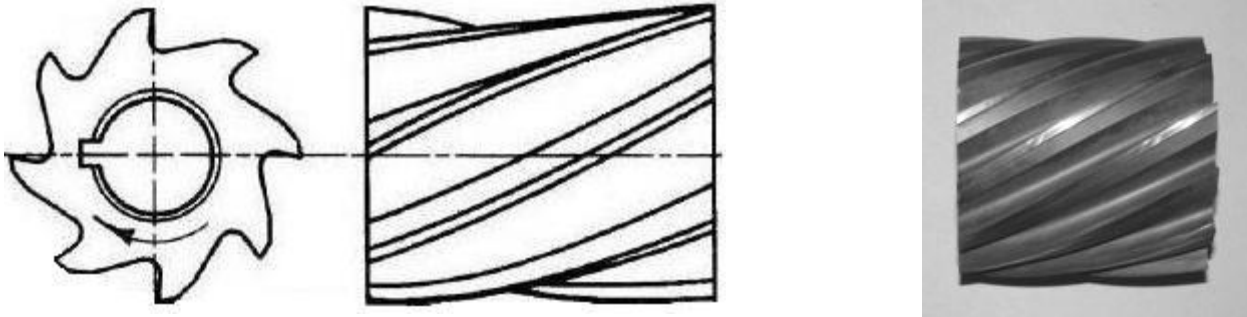

Fig. Slab or plain milling cutter

2. Side milling cutters: Single side or double sided type

These arbor mounted disc type cutters have a large number of cutting teeth at equal spacing on the periphery. Each tooth has a peripheral cutting edge and another cutting edge on one face in case of single side cutter and two more cutting edges on both the faces leading to double sided cutter. One sided cutters are used to produce one flat surface or steps comprising two flat surfaces at right angle. Both sided cutters are used for making rectangular slots bounded by three flat surfaces.

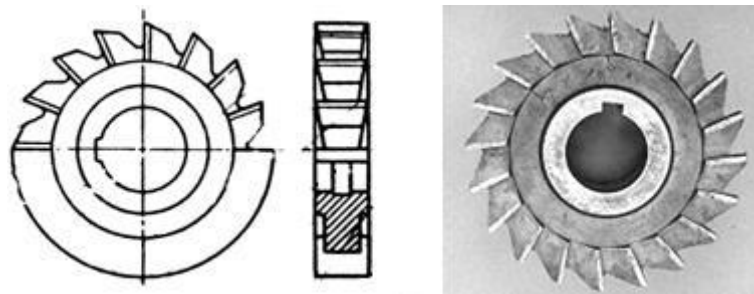

Fig. side milling cutters

3. Slitting saws or parting tools

These milling cutters are very similar to the slotting cutters having only one peripheral cutting edge on each tooth.

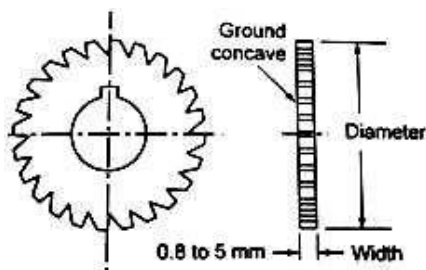

Fig. Slitting saw

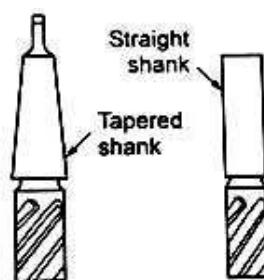

Fig. End milling cutters



Fig. Face milling cutter

4 End milling cutters: With straight or taper shank

The common characteristics of end milling cutters are:

- ❖ Mostly made of High Speed Steel.
- ❖ 4 to 12 straight or helical teeth on the periphery and face.
- ❖ Diameter ranges from about 1 mm to 40 mm.
- ❖ Very versatile and widely used in vertical spindle type milling machines.
- ❖ End milling cutters requiring larger diameter are made as a separate cutter body which is fitted in the spindle through a taper shank arbor (Shell end mills)

5 Face milling cutters

The main characteristics of face milling cutters are:

- ❖ Usually large in diameter (80 to 800 mm) and heavy.
- ❖ Used only for machining flat surfaces in different orientations.
- ❖ Mounted directly in the vertical and / or horizontal spindles.
- ❖ Coated or uncoated carbide inserts are clamped at the outer edge of the carbon steel body.
- ❖ Generally used for high production machining of large jobs.

6 Form cutters

These cutters have irregular profiles on the cutting edges in order to generate an irregular outline of the work. These disc type HSS cutters are generally used for making grooves or slots of various profiles.

Slotting cutters

Slotting cutters are of end mill type like T-slot cutter or dove tail cutter.

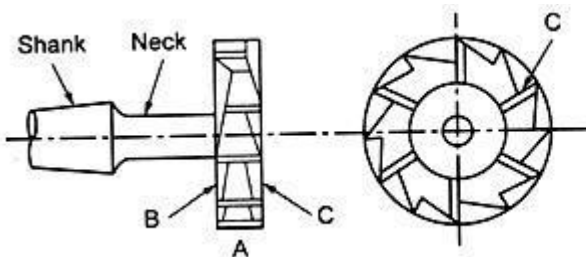

Fig. T-slot milling cutter

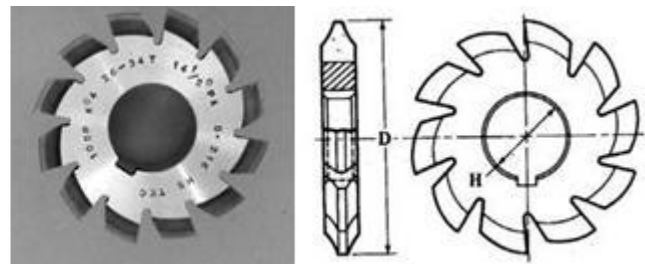

Fig. Involute gear milling cutter

Gear (teeth) milling cutters

Fig. 3.80 illustrates an involute gear milling cutter. Gear milling cutters are made of HSS and available mostly in disc form like slot milling cutters and also in the form of end mill for producing teeth of large module gears. The form of these tools conforms to the shape of the gear tooth-gaps bounded by two involutes. Such form relieved cutters can be used for producing teeth of straight and helical toothed external spur gears and worm wheels as well as straight toothed bevel gears.

Spline shaft cutters

These disc type HSS form relieved cutters are used for cutting the slots of external spline shafts having 4 to 8 straight axial teeth.

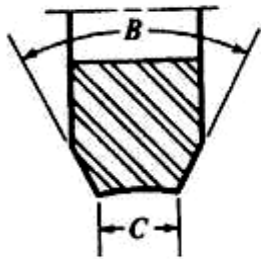

Fig. Tooth section of a spline shaft cutter

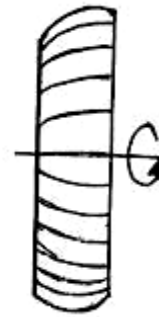

Fig. Tool form cutter

Tool form cutters

Form milling type cutters are also used widely for cutting slots or flutes of different cross section e.g. the flutes of twist drills, milling cutters, reamers etc., and gushing of hobs, taps, short thread milling cutters etc.

Thread milling cutters

These shank type solid HSS or carbide cutters having threaded like annular grooves with equi-spaced gushing are used in automatic single purpose milling machines for cutting the threads in large lot production of screws, bolts etc. Both internal and external threads are cut by the tool. These milling cutters are used for long thread milling also (e.g. lead screws, power screws, worms etc).

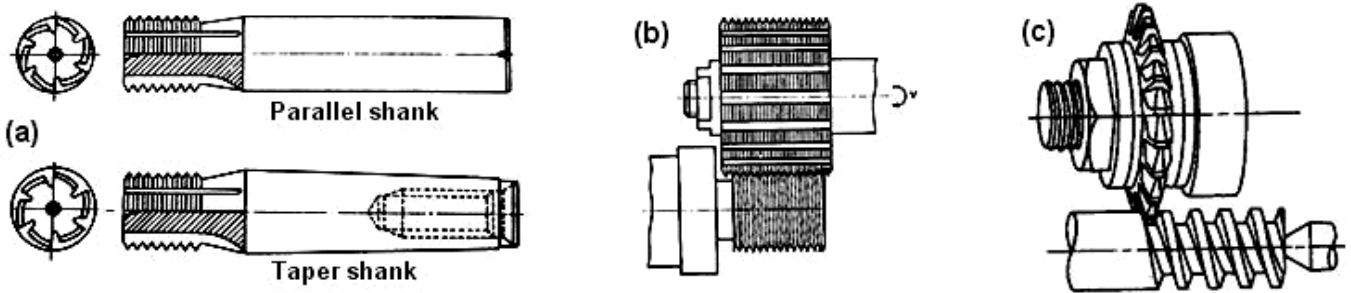

Fig. (a) Internal thread milling cutters (b) Short thread milling cutter (c) Long thread milling cutter

Convex and concave milling cutters

These cutters have teeth curved outwards or inwards on the circumferential surface to form the contour of a semicircle. These cutters produces concave or convex semicircular surface on the work pieces. The diameter of the cutters ranges from 50 mm to 125 mm and the radius of the semicircle varies from 1.5 mm to 20 mm.

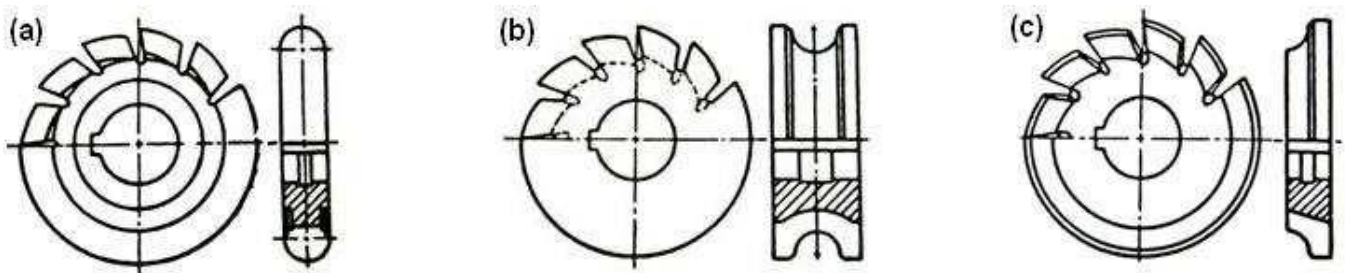

Fig. (a) Convex milling cutter (b) Concave milling cutter and (c) Corner rounding milling cutter

Corner rounding milling cutters

These cutters have teeth curved inwards on the circumferential surface to form the contour of a quarter circle. The cutter produces a convex quarter circular surface on the work piece. These are used for cutting a radius on the corners or edge of the work piece. The diameter of the cutter ranges from 1.5 mm to 20 mm.

Angle milling cutters

These cutters are made as single or double angle cutters and are used to machine angles other than 90^0 . The cutting edges are formed at the conical surface around the periphery of the cutter. The double angle milling cutters are mainly used for cutting spiral grooves on a piece of blank.

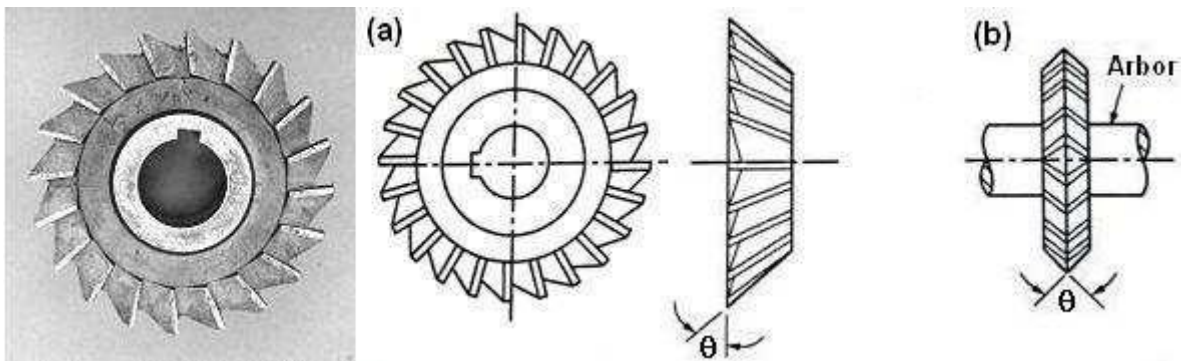

Fig. (a) Single angle milling cutter and (b) Double angle milling cutter

7 Woodruff key slot milling cutters

These cutters are small standard cutters similar in construction to a thin small diameter plain milling cutter, intended for the production of woodruff key slots. The cutter is provided with a shank and may have straight or staggered teeth.

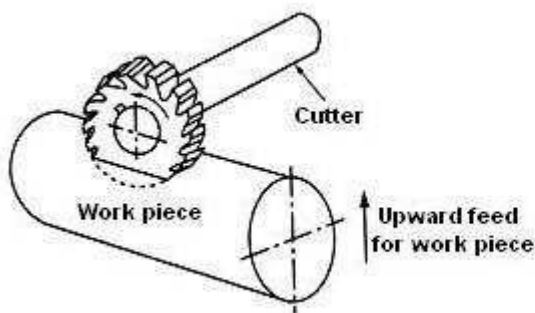

Fig. Woodruff key slot milling cutter

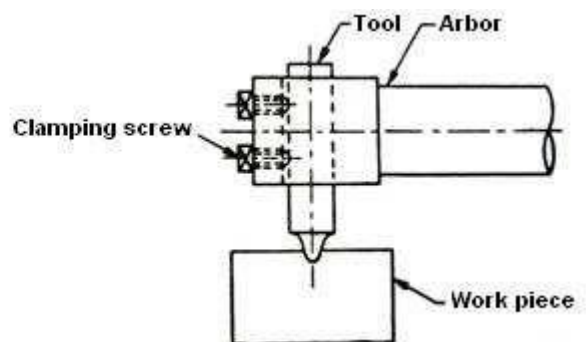

Fig. Schematic view of a fly cutter

8 Fly cutters

These are simplest form of cutters and are mainly used in experimental shops or in tool room works. The cutter consists of a single point cutting tool attached to the end of an arbor. This cutter may be considered as an emergency tool when the standard cutters are not available. The shape of the tool tip is the replica of the contour to be machined.

9 Ball nose end mill

Small end mill with ball like hemispherical end is often used in CNC milling machines for machining free form 3-D or 2-D contoured surfaces. These cutters may be made of HSS, solid carbide or steel body with coated or uncoated carbide inserts clamped.

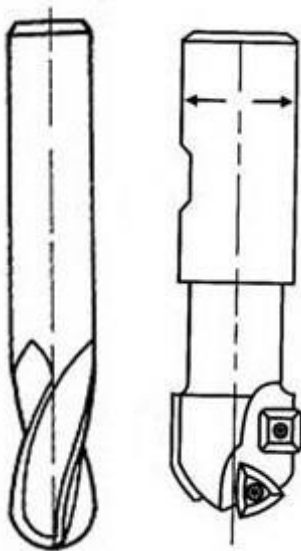

Fig. Ball nose end mills

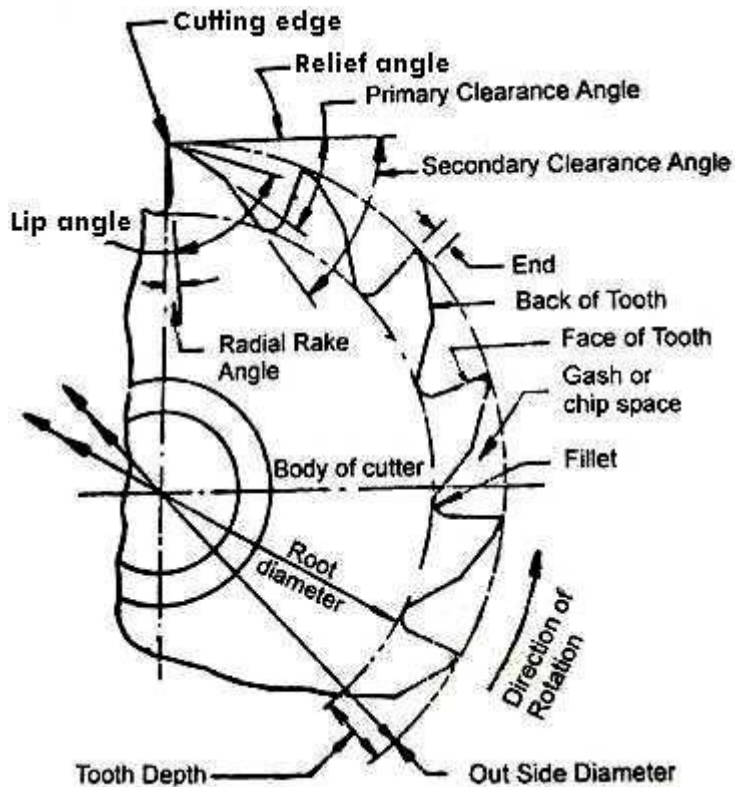

Fig. Elements of a plain milling cutter

ELEMENTS OF A PLAIN MILLING CUTTER

The major parts and angles of a plain milling cutter are illustrated in Fig. 3.89.

Body of cutter: The part of the cutter left after exclusion of the teeth and the portion to which the teeth are attached.

Cutting edge: The edge formed by the intersection of the face and the circular land or the surface left by the provision of primary clearance.

Face: The portion of the gash adjacent to the cutting edge on which the chip impinges as it is cut from the work

Fillet: The curved surface at the bottom of gash that joins the face of one tooth to the back of the tooth immediately ahead.

Gash: The chip space between the back of one tooth and the face of the next tooth. The part of the back of tooth adjacent to the cutting edge which is relieved to avoid interference between the surface being machined and the cutter.

Outside diameter: The diameter of the circle passing through the peripheral cutting edge.

Root diameter: The diameter of the circle passing through the bottom of the fillet.

Cutter angles: Similar to a single point cutting tool, the milling cutter teeth are also provided with rake, clearance and other cutting angles in order to remove metal efficiently.

Relief angle: The angle in a plane perpendicular to the axis. The angle between land of a tooth and tangent to the outside diameter of cutter at the cutting edge of that tooth.

Lip angle: The included angle between the land and the face of the tooth, or alternatively the angle between the tangent to the back at the cutting edge and the face of the tooth.

Primary clearance angle: The angle formed by the back of the tooth with a line drawn tangent to the periphery of the cutter at the cutting edge.

Secondary clearance angle: The angle formed by the secondary clearance surface of the tooth with a line drawn tangent to the periphery of the cutter at the cutting edge.

Rake angle (Radial): The angle measured in the diametral plane between the face of the tooth and a radial line passing through the tooth cutting edge. The rake angle which may be positive, negative or zero.

Fig. Three types of rake angle of a plain milling cutter

MILLING OPERATIONS

24. List out various milling operations. (Nov/Dec 2005 & April/May 2013,2015)

Milling machines are mostly general purpose machine tools and used for piece or small lot production. In general, all milling operations can be grouped into two types.

They are: peripheral milling and face milling.

Fig. Schematic view of the peripheral milling operation

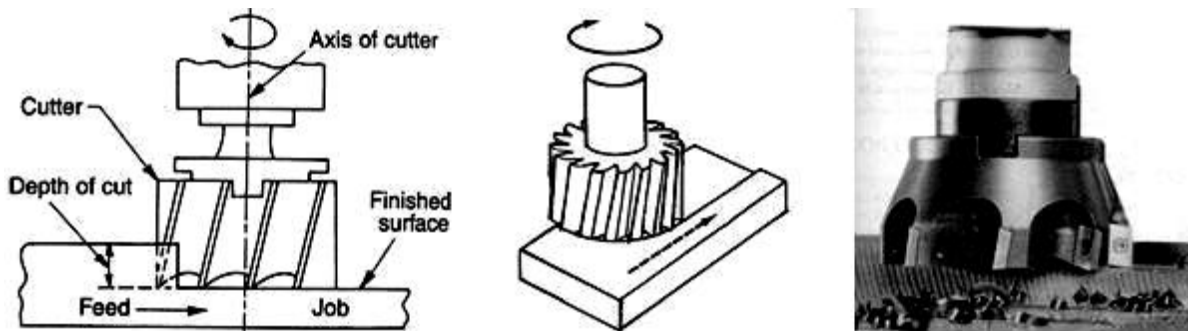
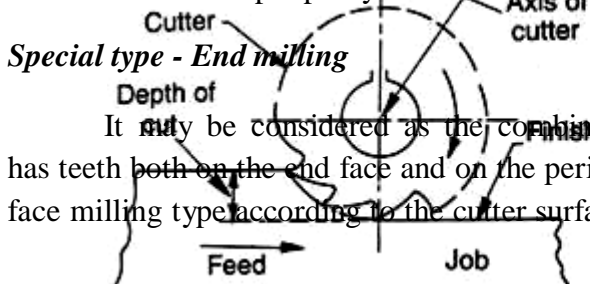

Fig. Schematic view of the face milling operation

Peripheral milling

Here, the finished surface is parallel to the axis of rotation of the cutter and is machined by cutter teeth on the periphery of the cutter.



Special type - End milling

It may be considered as the combination of peripheral and face milling operation. The cutter has teeth both on the end face and on the periphery. The cutting characteristics may be of peripheral or face milling type according to the cutter surface used.

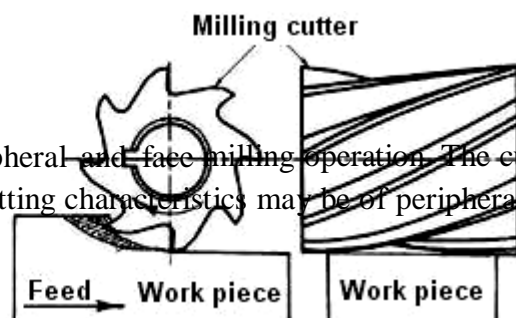

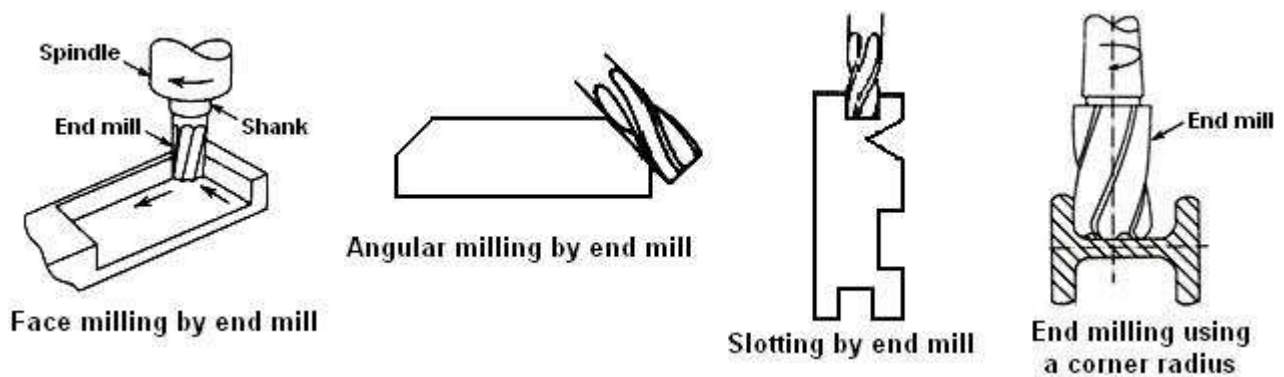

Fig. Schematic views of the different end milling operations

According to the relative movement between the tool and the work, the peripheral milling operation is classified into two types. They are: up milling and down milling.

Up milling or conventional milling Here, the cutter rotates in the opposite direction to the work table movement. In this, the chip starts as zero thickness and gradually increases to the maximum. The cutting force is directed upwards and this tends to lift the work piece from the work holding device. Each tooth slides across a minute distance on the work surface before it begins to cut, producing a wavy surface.

This tends to dull the cutting edge and consequently have a lower tool life.

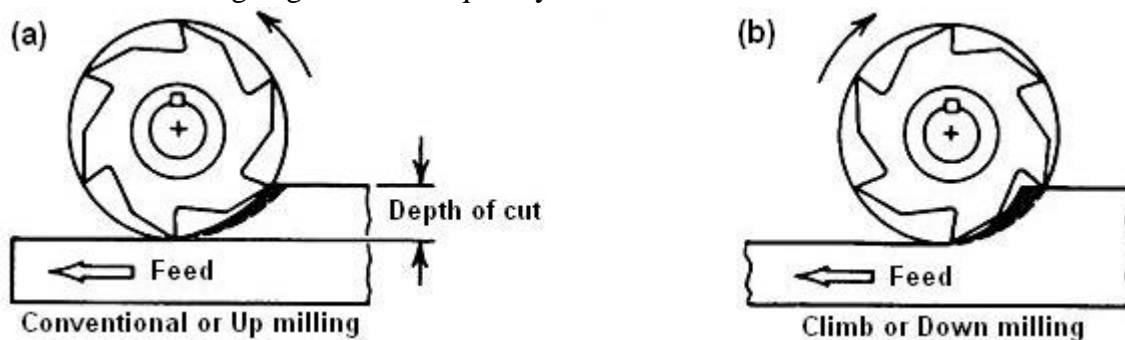

Fig. Schematic views of (a) Up milling process and (b) Down milling process

As the cutter progresses, the chip accumulate at the cutting zone and carried over with the teeth which spoils the work surface.

Down milling or climb milling

Here, the cutter rotates in the same direction as that of the work table movement. In this, the chip starts as maximum thickness and gradually decreases to zero thickness. This is suitable for obtaining fine finish on the work surface. The cutting force acts downwards and this tends to seat the work piece firmly in the work holding device. The chips are deposited behind the cutter and do not interfere with the cutting. Climb milling allows greater feeds per tooth and longer tool life between regrinds than up milling.

1 Basic functions of milling machine

Milling machines of various types are widely used for the following purposes:

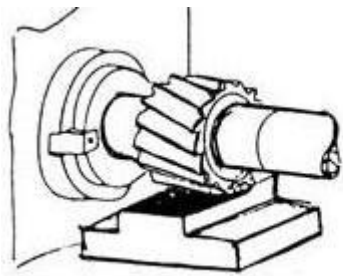

Flat surface in horizontal plane



Flat surface in vertical plane

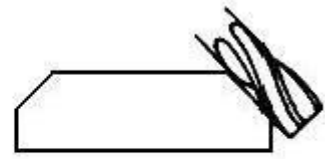

Flat surface in inclined plane

Fig. Producing flat surface in horizontal, vertical and inclined planes

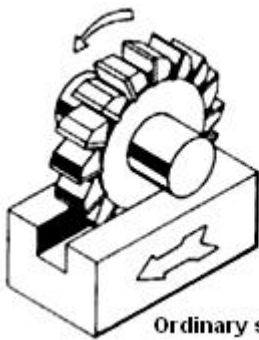

Ordinary slot

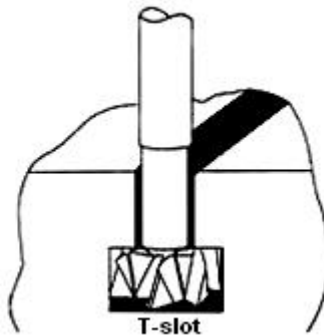

T-slot

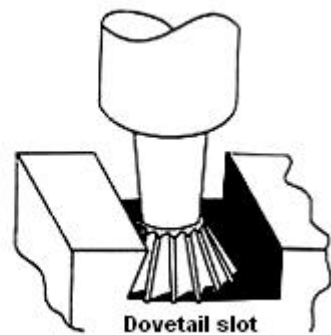

Dovetail slot

Fig. Machining slots of various cross sections

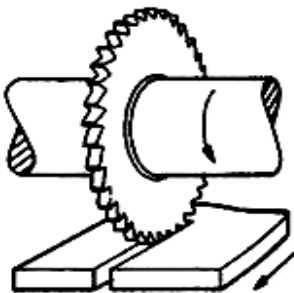

Fig. Parting by slitting saw

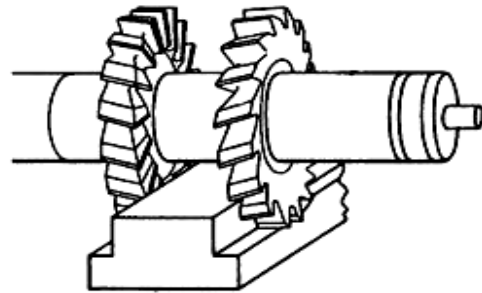

Fig. Straddle milling

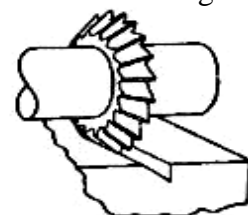
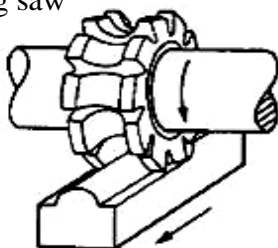

Fig. Form milling operations

Cutting helical grooves like flutes of the drills.



Fig. Cutting of drill flutes

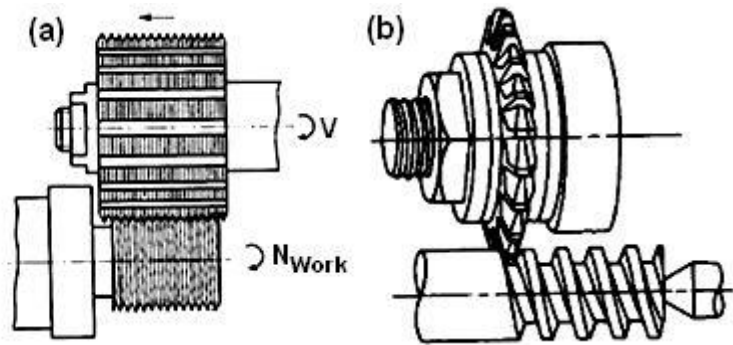

Fig. (a) Short thread milling (b) Long thread milling

Short thread milling for small size fastening screws, bolts etc. and long thread milling on large lead screws, power screws, worms etc.

Cutting teeth of spur gears, straight toothed bevel gears, worm wheels, sprockets in piece or batch production.

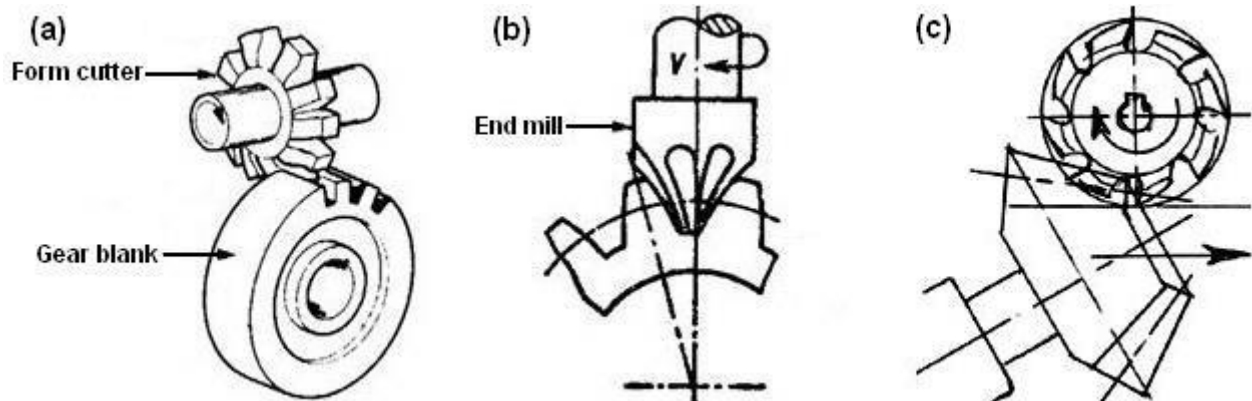

Fig. (a) Cutting teeth of spur gear by disc type cutter (b) Cutting teeth of spur gear by end mill

(c) Cutting teeth of straight toothed bevel gear by disc type cutter

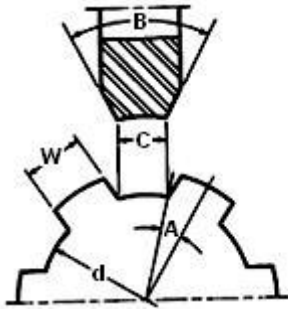

Fig. Cutting slots of external spline shaft

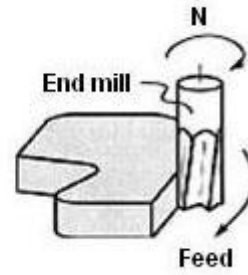

Fig. Profile milling of a cam

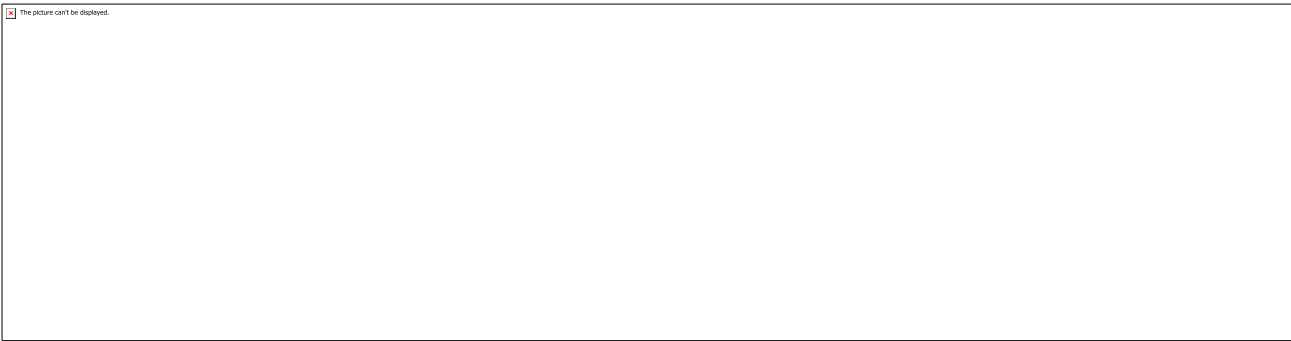

Fig. (a) Surface contouring of 3-D surface (b) Surface contouring of die cavity

Gang milling: Gang milling operation is employed for quick production of complex contours comprising a number of parallel flat or curved surfaces.

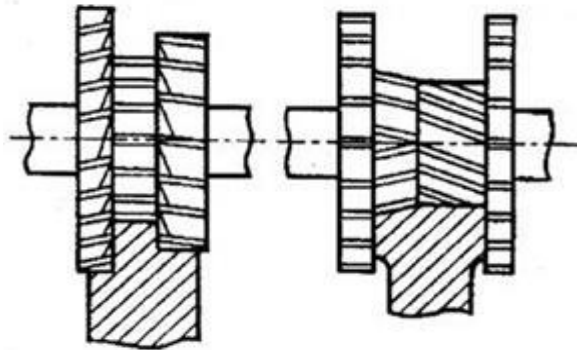

Fig. Gang milling

Turning by rotary tools: During turning like operations in large heavy and odd shaped jobs its speed (rpm) is essentially kept low. For enhancing productivity and better cutting fluid action rotary tools like milling cutters are used.

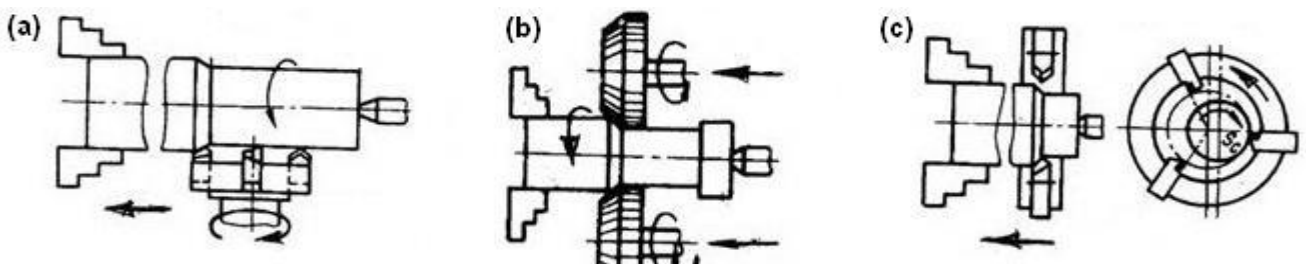
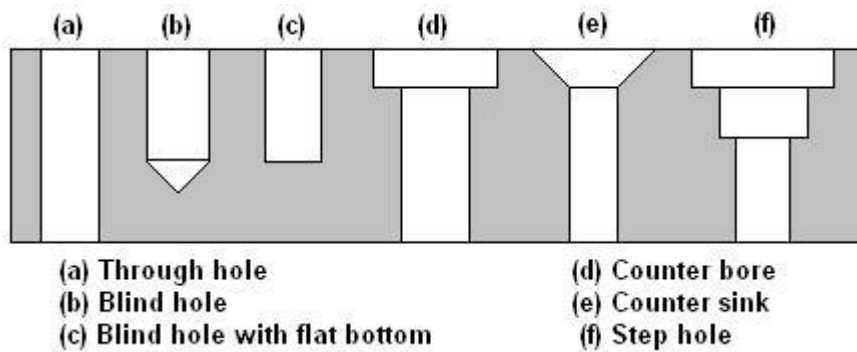

Fig. (a, b and c) Turning by rotary milling cutters

HOLE MAKING

25. Discuss the various hole making processes. (April/May 2011)

Machining round holes in metal stock is one of the most common operations in the manufacturing industry. It is estimated that of all the machining operations carried out, there are about 20 % hole making operations. Literally no work piece leaves the machine shop without having a hole made in it.



The various types of holes are shown in Fig.

26. Discuss any three gear manufacturing methods.

(a) Casting

- ❖ For casting of gears sand moulds or permanent moulds are prepared and then molten metal is poured into the mold cavity to get the required gear.
- ❖ Cast iron gears are made by this method comfortably. These gears (casted gears) cannot be very fine, these are rough, low strength, and with some inaccuracies in operation. Their cost of production is very low.
- ❖ This method is recommended for manufacturing of large sized gears where cost and power transmission are important than operating accuracy and noise level.

(b) Plastic Moulding.

- ❖ Plastic mould is also one of the ways of gear manufacturing. In plastic moulding gears of plastic material can be manufactured by using injection moulding or compression moulding.
- ❖ These are the very light duty gears used for transmission of very low amount of power but maintain velocity ratio accurately.
- ❖ Plastic moulding is also used for making gears of metal in this process the metallic work piece is heated first to bring it to a plastic state and then it is moulded to the required shape with the help of mechanical tools, die, and application of pressure.
- ❖ This process is used to make light duty smaller gears with accuracy. Non-ferrous metals can also be used as raw material for gear making by plastic moulding methods.

(c) Machining

- ❖ This is most widely used gear manufacturing method. Gear blank of accurate size and shape is first prepared by cutting it from metal stock.
- ❖ The gear blank can also be the metal casting. This method lies under the category of chip forming process.

- ❖ Gear is prepared by cutting one by one tooth in the gear blank of desired shape and size along its periphery. Different gear cutting methods are used in this category.

27. List the various Gears Shaping Process, explain any two with neat sketch and mention their advantage and limitations. (Apr/ May 2010)

Gear shaping is one of the gear generating methods. In this process gear tooth are accurately sized and shaped by cutting them by a multipoint cutting tool. Various gear shaping processes are listed and then described below:

- (a) Gear cutting by gear shaper.
- (b) Rack planning process.
- (c) Hobbing process.

Gear Cutting by Gear Shaper

- ❖ This process uses a pinion shaped cutter carrying clearance on the tooth face and sides and a hole at its centre for mounting it on a stub arbor or spindle of the machine. The cutter is mounted by keeping its axis in vertical position.
- ❖ It is also made reciprocating along the vertical axis up and down with adjustable and pre-decided amplitude. The cutter and the gear blank both are set to rotate at very low rpm about their respective axis.
- ❖ The relative rpm of both (cutter and blank) can be fixed to any of the available value with the help of a gear train. This way all the cutting teeth of cutter come in action one-by-one giving sufficient time for their cooling and incorporating a longer tool life.
- ❖ The specific advantages of the process over other processes, its product cycle time is very low and negligible dimensional variability from one unit to other in case of mass production. The main parameters to be controlled in the process are described below.

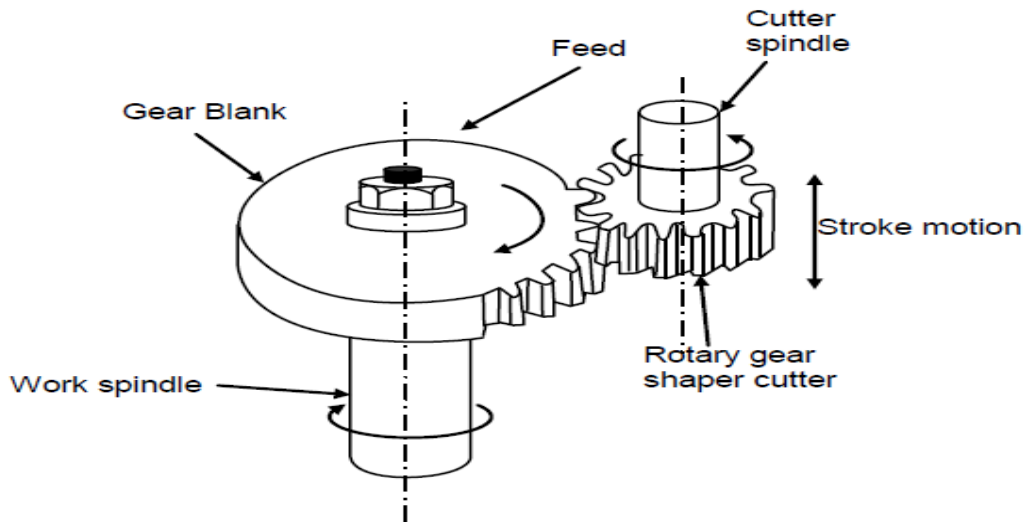

Process of Gear Cutting by Shaper Cutter

Cutting Speed

- ❖ Shaper cutter can move vertically upward and downward during the operation. The downward during the operation.
- ❖ The downward movement of the cutter is the cutting stroke and its speed (linear) with which it comes down is the cutting speed.
- ❖ After the completion of cutting stroke, cutter comes back to its top position which is called return stroke. There is no cutting in the return stroke. Length of cutting stroke can be adjusted to any value out of available values on the machine.

Indexing Motion

- ❖ Indexing motion is equivalent to feed motion in the gear shaping operation. Slow rotations of the gear cutter and work piece provide the circular feed to the operation.
- ❖ These two rpms are adjusted with the help of a change gear mechanism. The rpm are relatively adjusted such that each rotation of the cutter the gear blank revolves through revolution.

Where

n = Number of teeth of cutter, and

N = Number of teeth to be cut on the blank.

Depth of Cut

- ❖ Indexing movement or circular feed and reciprocating motions continue until the required numbers of teeth to the required depth are made all along the periphery of the gear blank.
- ❖ The required depth is maintained gradually by cutting the teeth into two or three pass. In each successive pass, the depth of cut is increased as compared to its previous path.
- ❖ This gradual increase in depth of cut takes place by increasing the value of linear feed in return stroke.
- ❖ The whole of this process is carried out on a gear shaping machine which is of the shape of a column and knee type milling machine. All the motions given to gear blank and gear cutter are set controlled very precisely.

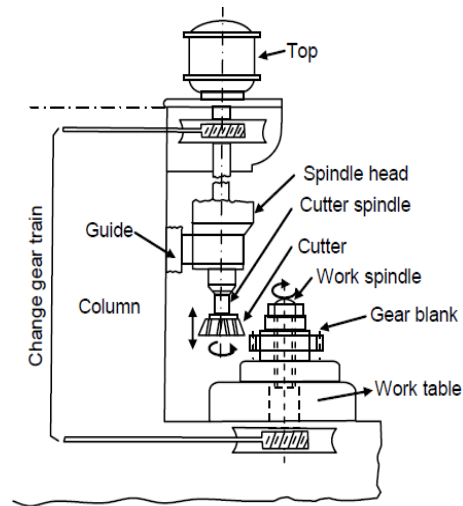

Setup for Gear Shaping Machine

Advantages of Gear Shaping Process

Main advantages of gear shaping process are described below:

- (a) Shorter product cycle time and suitable for making medium and large sized gears in mass production.
- (b) Different types of gears can be made except worm and worm wheels.
- (c) Close tolerance in gear cutting can be maintained.
- (d) Accuracy and repeatability of gear tooth profile can be maintained comfortably.
- (e) For same value of gear tooth module a single type of cutter can be used irrespective of number of teeth in the gear.

Limitations of gear shaping process:

- (a) It cannot be used to make worm and work wheel which is a particular type of gear.
- (b) There is no cutting in the return stroke of the gear cutter, so there is a need to make return stroke faster than the cutting stroke.
- (c) In case of cutting of helical gears, a specially designed guide containing a particular helix and helix angle, corresponding to the teeth to be made, is always needed on urgent basis.

Advantages of Gear Shaping Process

- (a) Shorter product cycle time and suitable for making medium and large sized gears in mass production.
- (b) Different types of gears can be made except worm and worm wheels.

(c) Close tolerance in gear cutting can be maintained.

(d) Accuracy and repeatability of gear tooth profile can be maintained comfortably.

(e) For same value of gear tooth module a single type of cutter can be used irrespective of number of teeth in the gear.

Limitations of gear shaping process:

(a) It cannot be used to make worm and work wheel which is a particular type of gear.

(b) There is no cutting in the return stroke of the gear cutter, so there is a need to make return stroke faster than the cutting stroke.

(c) In case of cutting of helical gears, a specially designed guide containing a particular helix and helix angle, corresponding to the teeth to be made, is always needed on urgent basis.

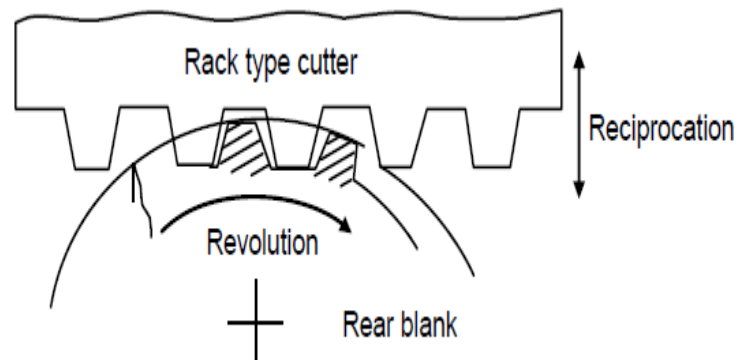

Gear shaping by rack type cutter

A few of the initial teeth of rack type cutter perform the cutting action and remaining teeth to very small removal of work piece material, these are used to maintain dimensional accuracy of the already cut teeth and to provide them a good finishing.

The basic principle of gear shaping is same but by slight altering the process some more different methods of gear shaping are discussed below.

Sunderland Process

- This process is named after the name of its inventor. In this process the cutter reciprocates in a direction towards and away from the gear blank.
- Cutter is gradually fed into the gear blank to the required depth. As soon as cutting is completed upto the desired depth, the blank rotates through one pitch distance.
- The cutter also moves along with the blank and then suddenly withdraws, stepped back by an amount equal to one pitch distance and again made to reciprocate in the normal way.
- The gear blank does not move till the completion of whole cutting upto the required depth. The whole motion and movement control is basically maintained with the help of synchronous motor and gear train.

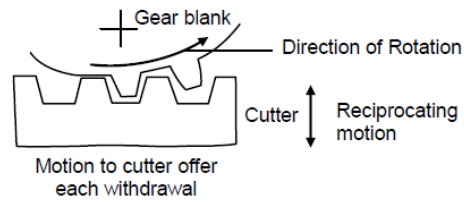

Process of Sunderland Gear Shaping Process

Mang Process

In this process gear blank is mounted on the machine table, keeping its axis in a vertical position. The cutter head, carrying rack type cutter, slides vertically in the sides provided at the front of the machine. The cutter can be set at any angle in a vertical plane. The cutter can also be made reciprocating in any direction. The rest of the process re-samples with other gear shaping processes.

28. Explain Gear Hobbing Process with neat sketch and list the Advantages and Limitations of Gear Hobbing Process. (Apr/ May 2004)

- ❖ In addition to the gear shaping process another process used for gear generation is gear hobbing. In this process, the gear blank is rolled with a rotating cutter called hob.
- ❖ Gear hobbing is done by using a multipoint cutting tool called gear hob. It looks like a worm gear having a number of straight flutes all around its periphery parallel to its axis. These flutes are so shaped by giving proper angles to them so that these work as cutting edges.
- ❖ In gear hobbing operation, the hob is rotated at a suitable rpm and simultaneously fed to the gear blank. The gear blank is also kept as revolving.
- ❖ Rpm of both, gear blank and gear hob are so synchronized that for each revolution of gear bob the gear blank rotates by a distance equal to one pitch distance of the gear to be cut.
- ❖ Motion of both gear blank and hob are maintained continuously and steady. The hob teeth behave like screw threads, having a definite helix angle.
- ❖ During operation the hob is tilted to helix angle so that its cutting edges remain square with the gear blank. Gear hobbing is used for making a wide variety of gears like spur gear, helical, hearing-bone, splines and gear sprockets, etc.

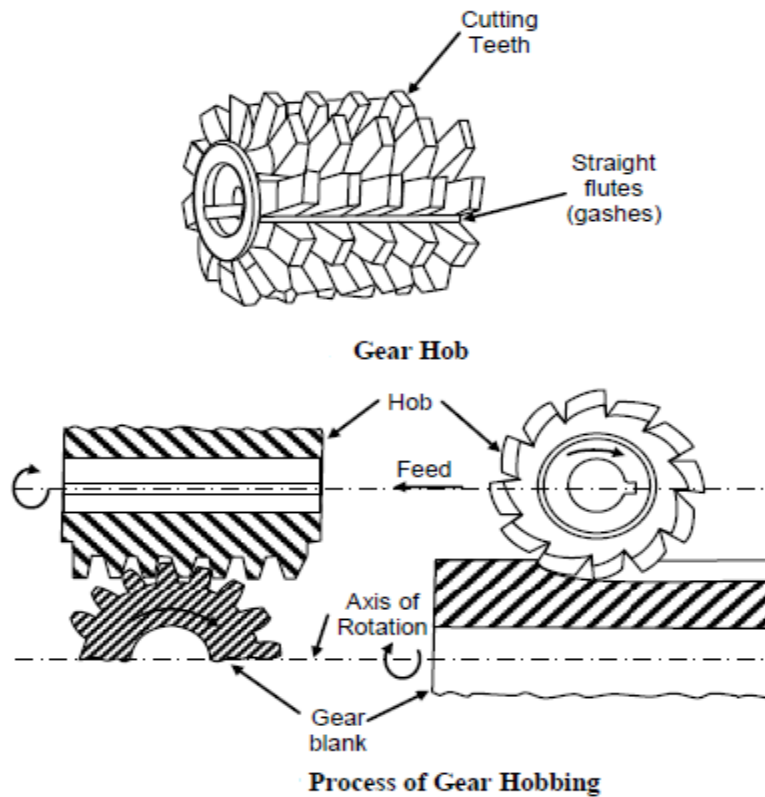

- ❖ Three important parameters are to be controlled in the process of gear hobbing indexing movement, feed rate and angle between the axis of gear blank and gear hobbing tool (gear hob).
- ❖ The aims of hob are set at an inclination equal to the helix angle of the hob with the vertical axis of the blank. If a helical gear is to be cut, the hob axis is set at an inclination equal to the sum of the helix angle of the hob and the helix angle of the helical gear. Proper gear arrangement is used to maintain rpm ratio of gear blank and hob.
- ❖ The operation of gear hobbing involves feeding the revolving hob till it reaches to the required depth of the gear tooth. Simultaneously it is fed in a direction parallel to the axis of rotation.
- ❖ The process of gear hobbing is classified into different types according to the directions of feeding the hob for gear cutting.

The classification is described as given below.

Hobbing with Axial Feed

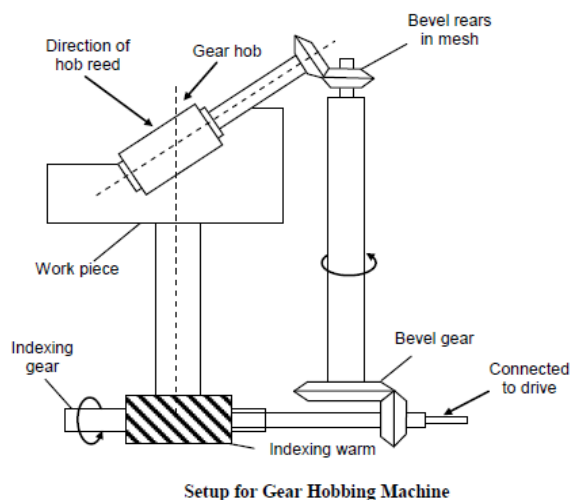

In this process the gear hob is fed against the gear blank along the face of the blank and parallel to its axis. This is used to make spur and helical gears.

Hobbing with Radial Feed

In this method the hob and gear blanks are set with their axis normal to each other. The rotating hob is fed against the gear blank in radial direction or perpendicular to the axis of gear blank. This method is used to make the worm wheels.

Hobbing with Tangential Feed

This is also used for cutting teeth on worm wheel. In this case, the hob is held with its axis horizontal but at right angle to the axis of the blank. The hob is set at full depth of the tooth and then fed forward axially. The hob is fed tangential to the face of gear blank.

Advantages and Limitations of Gear Hobbing Process

- (a) Gear hobbing is a fast and continuous process so it is realized as economical process as compared to other gear generation processes.
- (b) Lower production cycle time, i.e. faster production rate.
- (c) The process has a larger variability's in the following of sense as compared to other gear machining processes.
- (d) Capable to make wide variety of gears like spur gear, helical gears, worms, splines, sprockets, etc.
- (e) Process of required indexing (named so) is quite simplified and capable to make any number of teeth with consistent accuracy of module.
- (f) A special type of gear named herringbone gear can be generated by gear hobbing exclusively.
- (g) Wide variety of batch size (small to large volume) can be accommodated by this process.
- (h) Several gear blanks, mounted on the same arbor, can be processed simultaneously.
- (i) Hob is multipoint cutting tool having multi cutting teeth or edges at a time few number of cutting edges work so lots of time is available to dissipate the generated heat. There is no overheating and cutting tool.

29. Explain Finishing of Gear Teeth operations. (Apr/ May 2006)

- ❖ For smooth running, good performance and long service life, the gears need to be accurate in dimensions and forms to have high surface finish and to be hard and wear resistive at their tooth flanks which are achieved by some gear teeth finishing work after near accurate preforming and machining.
- ❖ Small gears made by cold rolling generally do not require further finishing. If a rolled gear needs further surface hardening only then little finishing by grinding or lapping is done after hardening.
- ❖ Gears produced to near-net-shape by die casting, powder metallurgy, extrusion, blanking etc. need little finishing. But machined and hardened gear teeth are essentially finished for accuracy and surface finish.
- ❖ Common methods of gear teeth finishing Gear teeth, after performing and machining, are finished generally by;
 - For soft and unhardened gears
 - ✓ Gear shaving
 - ✓ Gear rolling or burnishing
 - For hard and hardened gears
 - ✓ Grinding
 - ✓ Lapping

- For soft but precision gears
 - ✓ Shaving followed by surface hardening and then lapping

Gear finishing operation

- Surface of gear teeth produced by any of the generating process is not accurate and of good quality (smooth).
- Dimensional inaccuracies and rough surface generated so become the source of lot of noise, excessive wear, play and backlash between the pair of gears in mesh. These all result in loss of power to be transmitted and incorrect velocity ratios.
- This can be summarized as inefficient power transmission. In order to overcome these problems some finishing operations are recommended for the produced gears. Sometimes poor quality of finish and dimensional inaccuracies occur due to hardening of a produced gear.
- The prepared (generated) gear is subjected to various hardening processes leading to various problems creating inaccuracies. So finishing operations are to be done at last.

Gear shaving

- Gear shaving is a process of finishing of gear tooth by running it at very high rpm in mesh with a gear shaving tool.
- A gear shaving tool is of a type of rack or pinion having hardened teeth provided with serrations. These serrations serve as cutting edges which do a scrapping operation on the mating faces of gear to be finished.

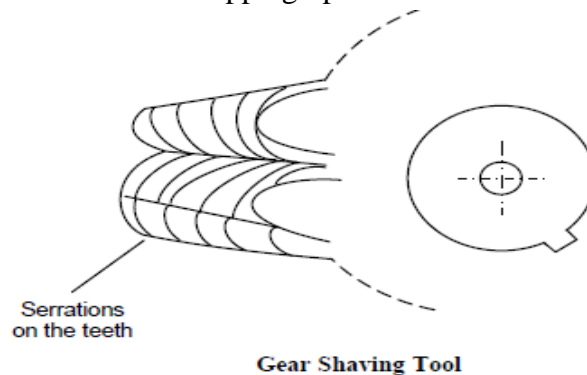

Roll Finishing Of Gear Tooth

- This process involves use of two hardened rolling dies containing very accurate tooth profile of the gear to be finished. The gear to be finished is in between the two dies and all three are revalued about their axis.
- Pressure is exerted by both the rolling dies over the gear to be finished. The material of the die is very hard as compare to the material of gear so there is a plastic deformation of high points and burrs on the profile of gear tooth resulting to smooth surface.
- The gear to be finished is mounted on a vertical reciprocating shaft and it is kept in mesh with three hardened burnishing compatible gears.
- The burnishing gears are fed into the cut gear and revalued few revaluations in both the directions. Plastic deformation of irregularities in cold state takes place to give smooth surface of the gear.

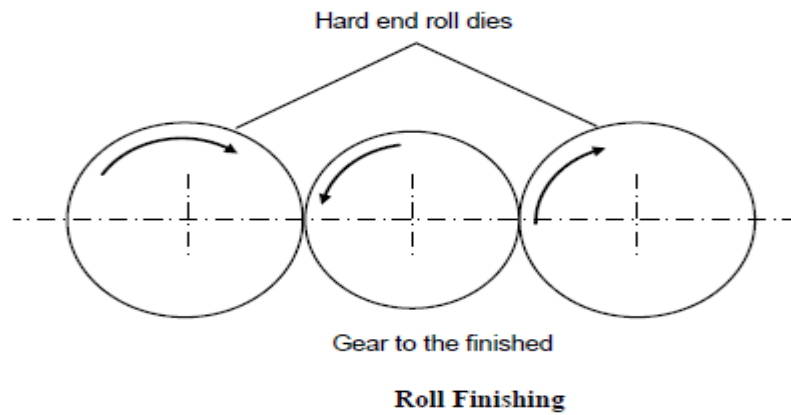

Gear Grinding

In this operation abrasive grinding wheel of a particular shape and geometry are used for finishing of gear teeth. Gear to be finished is mounted and reciprocated under the grinding wheel. Each of the gear teeth is subjected to grinding operations this way.

Gear teeth grinding

Grinding is a very accurate method and is, though relatively expensive, more widely used for finishing teeth of different type and size of gears of hard material or hardened surfaces. The properly formed and dressed wheel finishes the gear teeth flanks by fine machining or abrading action of the fine abrasives. Like gear milling, gear grinding is also done on two principles

- Forming
- Generation, which is more productive and accurate.

Gear teeth grinding on forming principle

- This is very similar to machining gear teeth by a single disc type form milling cutter. Where the grinding wheel is dressed to the form that is exactly required on the gear. Need of indexing makes the process slow and less accurate.
- The wheel or dressing has to be changed with change in module, pressure angle and even number of teeth. Form grinding may be used for finishing straight or single helical spur gears, straight toothed bevel gears as well as worm and worm wheels.

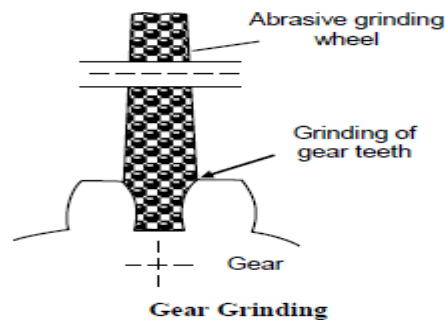

Gear teeth grinding on generation principle

The simplest and most widely used method is very similar to spur gear teeth generation by one or multi-toothed rack cutter. The single or multi-ribbed rotating grinding wheel is reciprocated along the gear teeth as shown. Other tool – work motions remain same as in gear teeth generation by rack type cutter.

Lapping of a Gear

The process of lapping is used to improve surface finish of already made teeth. In this process the gear to be lapped is run under load in mesh with cast iron toothed laps.

Abrasive paste is introduced between the teeth. It is mixed with oil and made to flow through the teeth. One of the mating members (either gear or lapping tool) is reciprocated axially along with the revolutions.

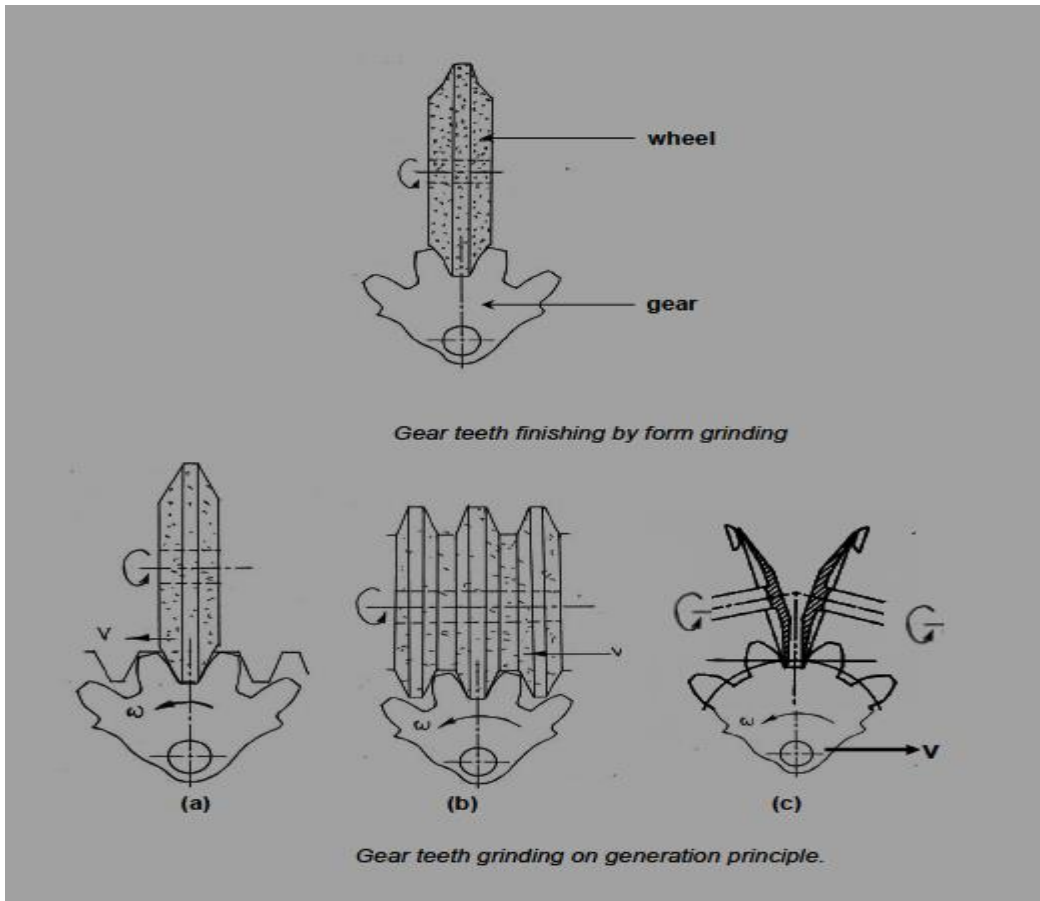

Gear Honing

- It is used for super finishing of the generated gear teeth. Honing machines are generally used for this operation. The hones are rubbed against the profile generated on the gear tooth. Gear lapping and gear honing are the last finishing operations of a gear generation process.
- In the above gear finishing operations some operations are based on metal cutting by removing very small size of chips like gear shaving, gear grinding, lapping and honing and some other operations like gear burnishing, roll finishing and based on finishing by plastic deformation of metal.

30. Write down the General Applications of Gears.

Gears of various type, size and material are widely used in several machines and systems requiring positive and stepped drive. The major applications are:

- Speed gear box, feed gear box and some other kinematic units of machine tools.
- Speed drives in textile, jute and similar machineries
- Gear boxes of automobiles
- Speed and / or feed drives of several metal forming machines
- Machineries for mining, tea processing etc.
- Large and heavy duty gear boxes used in cement industries, sugar industries, cranes, conveyors etc.
- Precision equipment clocks and watches.
- Industrial robots and toys.

UNIT - IV

ABRASIVE PROCESS AND BROACHING

Abrasive processes: grinding wheel – specifications and selection, types of grinding process– cylindrical grinding, surface grinding, centreless grinding and internal grinding- Typical applications – concepts of surface integrity, broaching machines: broach construction – push, pull, surface and continuous broaching machines.

2 MARKS QUESTIONS

ABRASIVE PROCESSES: GRINDING WHEEL – SPECIFICATIONS AND SELECTION

1. What are the specifications of grinding wheel? (Apr/ May 2011)

Grinding wheel consists of hard abrasive grains called grits, which perform the cutting or material removal, held in the weak bonding matrix. A grinding wheel commonly identified by the type of the abrasive material used.

2. Explain Geometrical specification.

This is decided by the type of grinding machine and the grinding operation to be performed in the workpiece. This specification mainly includes wheel diameter, width and depth of rim and the bore diameter. The wheel diameter, for example can be as high as 400mm in high efficiency grinding or as small as less than 1mm in internal grinding. Similarly, width of the wheel may be less than an mm in dicing and slicing applications. Standard wheel configurations for conventional and super abrasive grinding wheels are shown in Fig.

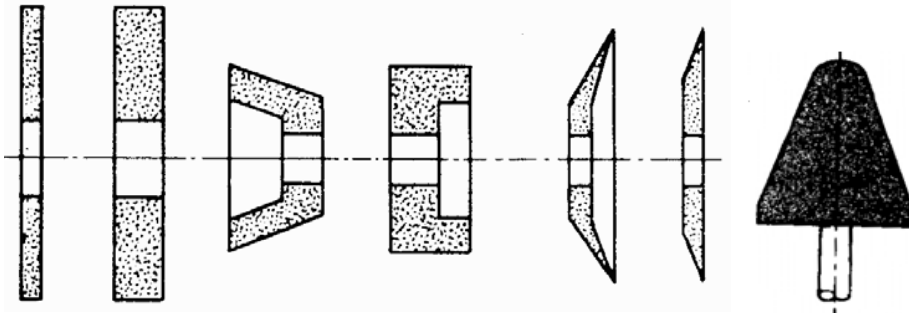

Standard wheel configuration for conventional grinding wheel

3. What is Compositional specification?

Compositional specifications

Specification of a grinding wheel ordinarily means compositional specification. Conventional abrasive grinding wheels are specified encompassing the following parameters.

- 1) The type of grit material
- 2) The grit size
- 3) The bond strength of the wheel, commonly known as wheel hardness
- 4) The structure of the wheel denoting the porosity i.e. the amount of inter grit spacing
- 5) The type of bond material

6) Other than these parameters, the wheel manufacturer may add their own identification code prefixing or suffixing (or both) the standard code.

4. Mention four important factors that influence the selection of grinding wheel. (Nov/Dec 2008)

The selection of a grinding wheel is based on the following factors:

1. Size and shape of wheel.
2. Kind of abrasive
3. Grain size of abrasive particles
4. Grade of bond
5. Structure
6. Kind of bond material
7. Functioning of grinding wheel
8. Other factors: Wheel speed, work speed, Materials.

5. What are the variable factors in wheel selection?

Variable factors in wheel selection:

1. Composition of the workpiece material
2. Cutting fluid
3. Material hardness
4. Work finish

6. Give the Fixed factors in wheel selection.

Fixed factors in wheel selection:

1. H.P of the machine
2. Severity of the grinding
3. Area of grinding contour
4. Wheel speed
5. Fluid

7. How is the grinding wheel designated? (Apr/May 2013)

Grinding wheels are produced by mixing the appropriate grain size of the abrasive with the required bond and pressed into shape. The characteristic of the grinding wheel depend upon a number of variables.

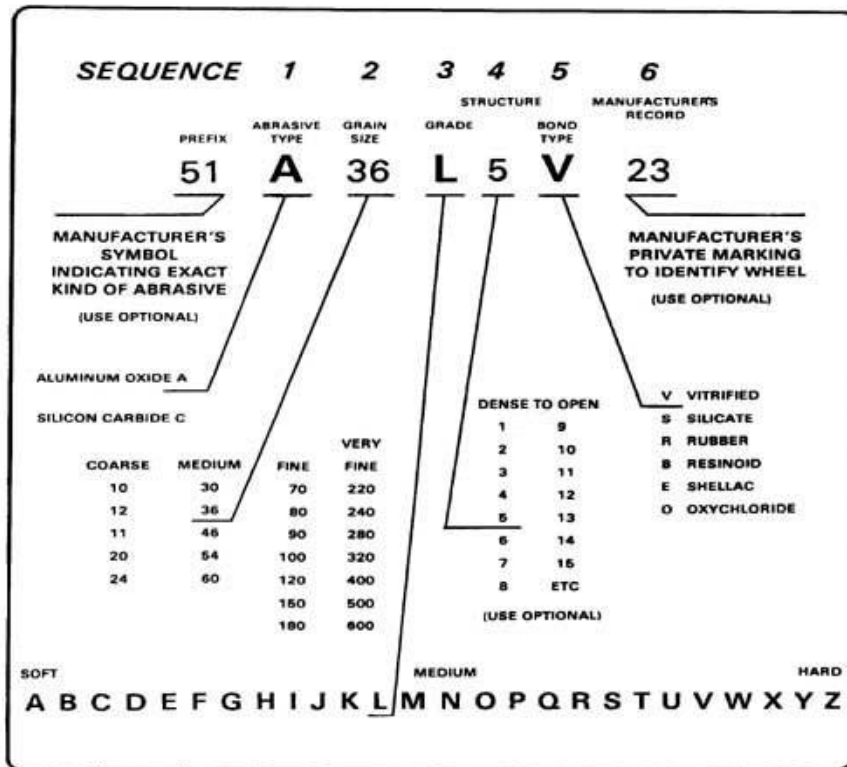

8. What are abrasives?

Abrasives:

These are hard materials with adequate toughness which act as cutting edges for a sufficiently long time. They also have the ability to fracture into small pieces when the force increases.

9. Give the types of abrasives.

Types of abrasives:

There are two types of abrasives:

- Natural abrasives
- Artificial abrasives or manufactured.

10. Write on natural abrasives.

Natural Abrasives:

These are naturally available in the earth. They have more impurities. So for most of the purpose the natural avrasives are not used.

Various natural abrasives:

1. Sand Stone or solid quartz
2. Emery
3. Diamond

4. Garher

11. Name artificial abrasive materials. (Nov/ Dec 2012.)

The abrasives that are generally used are:

1. Aluminium oxide
2. Silicon oxide
3. Ceramic aluminium oxide

Super abrasives:

1. Diamond
2. Cubic boron nitride(CBN)

12. Write on Aluminium oxide abrasive.

Aluminium oxide

- ❖ Aluminium oxide may have variation in properties arising out of differences in chemical composition and structure associated with the manufacturing process.
- ❖ Pure Al_2O_3 grit with defect structure like voids leads to unusually sharp free cutting action with low strength and is advantageous in fine tool grinding operation, and heat sensitive operations on hard, ferrous materials.
- ❖ Regular or brown aluminium oxide (doped with TiO_2) possesses lower hardness and higher toughness than the white Al_2O_3 and is recommended heavy duty grinding to semi finishing. Al_2O_3 alloyed with chromium oxide (<3%) is pink in colour.
- ❖ Monocrystalline Al_2O_3 grits make a balance between hardness and toughness and are efficient in medium pressure heat sensitive operation on ferrous materials.

13. Give properties of silicon carbide abrasive.

Silicon carbide

- Silicon carbide is harder than alumina but less tough. Silicon carbide is also inferior to Al_2O_3 because of its chemical reactivity with iron and steel.
- Black carbide containing at least 95% SiC is less hard but tougher than green SiC and is efficient for grinding soft nonferrous materials.
- Green silicon carbide contains at least 97% SiC. It is harder than black variety and is used for grinding cemented carbide.

14. What can be machined using Diamond abrasives?

Diamond:

- Diamond grit is best suited for grinding cemented carbides, glass, sapphire, stone, granite, marble, concrete, oxide, non-oxide ceramic, fiber reinforced plastics, ferrite, graphite.
- Natural diamond grit is characterized by its random shape, very sharp cutting edge and free cutting action and is exclusively used in metallic, electroplated and brazed bond.
- Monocrystalline diamond grits are known for their strength and designed for particularly demanding application. These are also used in metallic, galvanic and brazed bond.
- Polycrystalline diamond grits are more friable than monocrystalline one and found to be most suitable for grinding of cemented carbide with low pressure. These grits are used in resin bond.

15. What is the abrasive used when diamond is not suitable?

CBN (cubic boron nitride):

- Diamond though hardest is not suitable for grinding ferrous materials because of its reactivity. In contrast, cBN the second hardest material, because of its chemical stability is the abrasive material of choice for efficient grinding of HSS, alloy steels, HSTR alloys.
- Presently CBN grits are available as monocrystalline type with medium strength and blocky monocrystals with much higher strength. Medium strength crystals are more friable and used in resin bond for those applications where grinding force is not so high. High strength crystals are used with vitrified, electroplated or brazed bond where large grinding force is expected.
- Microcrystalline CBN is known for its highest toughness and auto sharpening character and found to be best candidate for HEDG and abrasive milling. It can be used in all types of bond.

16. Define hardness of the grinding wheel. (Nov/Dec 2010)(Apr/May 2010)

Grinding wheel hardness:

Hardness is rated from A-Z with 'A' being the weakest bond and 'Z' being the strongest. A weak bond is preferred for grinding harder materials while a stronger bond is desired for softer materials. A typical weak bond for steel would be in the 'F, G or H' range. A medium hardness would be in the 'I, J or K' range. And stronger bonds in the 'L, M, or O' range. Hardness is dependent on the grit type, the material being ground, the amount of stock removed, and a number of other factors. Hardness grades are typically linear: If you increase the hardness by one letter grade (An H to and I for instance) it could give you double the wheel life.

17. What is meant by “grade” of a grinding wheel? (Apr/May 2011)

Grade:

The term grade indicates the strength of bond in a wheel, the power of the abrasive particles to hold together and resist disintegration under the cutting pressure.

- Higher the proportion of bond for a specified quantitative of abrasives particles harder wheel will be used.
- Lower proportion will render it soft, easily broken.
- Hard wheel will retain these particles for a much longer period.
- Machine condition also plays an important role in this selection.
- Harder wheels are employed tool post grinder on lathes.

Different wheel grades are represented by English alphabets from A to Z. 'A' being the softest and 'Z' the hardest.

18. What is meant by “structure” of a grinding wheel? (Apr/May 2011)

Structure or grain spacing:

Structure is basically the spacing between abrasive grains. An open structure would be 12 or higher while a closer structure would be 6 or so. Here again, the structure depends on a variety of factors not the least of which is how difficult the material is to grind. One would think that a closer spacing would make a tougher wheel but this is only true to a point: With fewer bonds holding the individual abrasive grains, the softer the wheel would be. Also, the same holds true for a very open structure: If the grains are wide spaced you have fewer grains to grind with but a greater amount of bond holding each grain -- This could make the wheel tougher. Grinding wheel engineers will typically adjust the BOND STRENGTH depending on the application.

19. Define Grit Size.

Grit size:

Grit size typically runs from coarse (16 -24 grit), medium (36 - 60 grit) and fine (80-120 grit). Superfine grits run from 150 and higher. Grinding wheels usually will be between 24 and 100 grit. Honing stones and jointing stones and other polishing abrasives will be 150 grit and higher. Use a coarse grit for fast, aggressive stock removal and finer grits for less stock removal but better surface finish.

20. Write short notes on Bonds.

Bond:

A bond is an adhesive material. It holds the abrasive grains together to form the grinding wheel.

21. Write on Shellac and Oxychloride bond.

Shellac bond

At one time this bond was used for flexible cut off wheels. At present use of shellac bond is limited to grinding wheels engaged in fine finish of rolls.

Oxychloride bond

It is less common type bond, but still can be used in disc grinding operation. It is used under dry condition.

22. Explain rubber and metal bond.

Rubber bond

Its principal use is in thin wheels for wet cut-off operation. Rubber bond was once popular for finish grinding on bearings and cutting tools.

Metal bond

Metal bond is extensively used with superabrasive wheels. Extremely high toughness of metal bonded wheels makes these very effective in those applications where form accuracy as well as large stock removal is desired.

23. Name the bond for making wheels for abrasive milling.

Electroplated bond

This bond allows large (30-40%) crystal exposure above the bond without need of any truing or dressing. This bond is specially used for making small diameter wheel, form wheel and thin superabrasive wheels. Presently it is the only bond for making wheels for abrasive milling and ultra high speed grinding.

24. What is the bond which would replace electroplated bond?

Brazed bond

This is relatively a recent development, allows crystal exposure as high 60-80%. In addition grit spacing can be precisely controlled. This bond is particularly suitable for very high material removal either with diamond or cBN wheel. The bond strength is much greater than provided by electroplated bond. This bond is expected to replace electroplated bond in many applications.

25. What is meant by Grinding?

Grinding is a metal removal process or operation performed by means of rotating abrasive wheel at a very high speed that acts as a cutting tool against the work piece. The abrasive wheel is

formed by many small individual abrasive grains. Each sharp edge of a grain cuts a small chip of material from the workpiece.

26. Why is grinding called finishing process?

Grinding is called finishing process, because the grinding process removes metal usually in the order of 0.25 to 0.50 mm. This produces very high quality surface finish.

27. Give the purpose of grinding.

Grinding is used for the following purpose:

- i) Machining materials which are too hard for other machining processes such as tool and die steels and hardened steel material.
- ii) Close dimensional accuracy of the order of 0.3 to 0.5 μm and,
- iii) High degree of surface smoothness such $R_a = 0.15$ to $1.25 \mu\text{m}$.

28. What is the approximate thickness of metal removed and its accuracy dimension in grinding operation?

The approximate thickness of metal removed in grinding operation is 0.01 to 0.03 mm. Accuracy dimension in the order of 0.000025mm.

TYPES OF GRINDING PROCESS

29. What are the main basic types of grinding?

The two main basic types of grinding are:

- a) Rough or Non-precision grinding,
- b) Finish or precision grinding.

30. Write on rough grinding.

Rough grinding is a commonly used method of removing excess material from castings, forgings and weldments or as a method for removing or snagging thin fins, sharp corners, burrs or other unwanted projections from various shapes of workpieces. The work is pressed against the hard wheel or vice-versa. The accuracy and surface finish obtained are of secondary importance. Snagging is done where a considerable amount of metal is removed without regard to the accuracy of the finished surface.

31. What are the different types of rough grinders?

Rough grinders are those grinding machines whose chief work is the removal of stock without any reference to the accuracy of the results. They include:

- a) Floor stand and bench type grinders
- b) Portable and flexible shaft grinders
- c) Swing frame grinders

d) Abrasive belt grinders.

32. Write on precision grinders.

Precision grinders: This is the principal production of cutting material that are too hard to be machined by other conventional tool or for producing surfaces on parts to higher dimensional accuracy and finer surface finish as compared to other manufacturing methods. Since cutting edges of the grits are extremely thin it is possible to remove much smaller chips and refine surfaces to a much greater accuracy of finish and dimension than with other machining methods.

33. What are the types of precision grinders?

Types of precision grinders:

- a) Cylindrical grinders
- b) Internal grinders
- c) Surface grinders
- d) Tool and cutter grinders
- e) Special grinding machines

CYLINDRICAL GRINDING

34. Draw the diagram for cylindrical grinding.

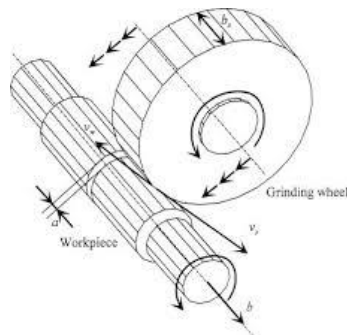

SURFACE GRINDING

35. What is surface grinding?

Surface grinding is the process of producing and finishing flat surfaces by means of a grinding machine using a revolving abrasive wheel. The work may be ground by either the periphery or by the end face of the grinding wheel. The workpiece is reciprocated at a constant speed below or on the end face of the grinding wheel.

36. What are the types of surface grindings?

The different types of surface grindings are:

1. Reciprocating table surface grindings
 - a. Horizontal type
 - b. Vertical type.
2. Rotating table.

- a. Horizontal spindle
- b. Vertical spindle.

37. What types of work can be ground by a surface grinder?

Surface grinder can be used for flat surface, irregular surface, curved surface, tapered surface, convex surface and concave surface.

Machine guide ways, piston rings, valves, dies, surface plates, etc., are some of the parts which are finished by surface grinding.

INTERNAL GRINDERS

38. What are the types of internal grinders?

The different types of internal grinders are:

1. Chucking grinders
 - a) Plain
 - b) Universal
2. Planetary grinders
3. Centreless grinders

39. What is the use of internal grinders?

Use of internal grinders:

Internal grinders are used:

- * To finish straight, tapered, or formed holes to correct size, shape and finishing.
- *The depth of cut depends upon the diameter of the hole being ground may vary from 0.02 to 0.05 mm in roughing and from 0.002 to 0.01mm in finishing operations.

40. What are the different types of external grinders?

External grinders are divided into

- a) Plain cylindrical grinders
- b) Universal grinders
- c) Special grinders such as the centre less grinders.

41. What are the uses of external grinders?

External grinders are used for:

- Grinding cylindrical surfaces
- To produce external cams
- Eccentrics and,
- Special form on the outside diameter of the work.

42. List out the surfaces ground by the plain cylindrical grinder.

Surfaces ground by the plain cylindrical grinder:

- External cylinders

- Tapers
- Fillets
- undercuts
- shoulders

43. Give the additional features in universal machine.

A universal machine has the following additional features:

- a) The head stock spindle may be used alive or dead as desired.
- b) The headstock can be swiveled at an angle in horizontal plane.
- c) The wheel head and slide can be swiveled and traversed at any angle to Grind tapered surfaces having large taper angles.

CENTRE LESS GRINDING

44. Explain briefly the meaning of Centre less grinding.

Grinding the diameter of the work piece without mounting on centres is known as centre less grinding. The principal elements of an external centreless grinder are the grinding wheel, regulating wheel or backup wheel and the work rest. Both wheels are rotated in the same direction. The work rest is located between the wheels. The work is placed upon the work rest, and the latter, together with the regulating wheel, is fed forward, forcing the work against the grinding wheel.

45. What are the operations done in centre less grinders?

The various operations are:

- a) Through feed grinding
- b) In feed grinding
- c) End feed grinding

46. Write on through feed.

In through feed, the work enters from one side of the machine and comes out from the other side with guides at the both ends. This method is used when there are no shoulders or other forms to interfere with the passage of the work. It is useful for grinding long, slender shafts or bars. The layer of metal removed by the grinding wheel in one pass reduces the diameter of the workpiece by 0.02 to 0.3 mm.

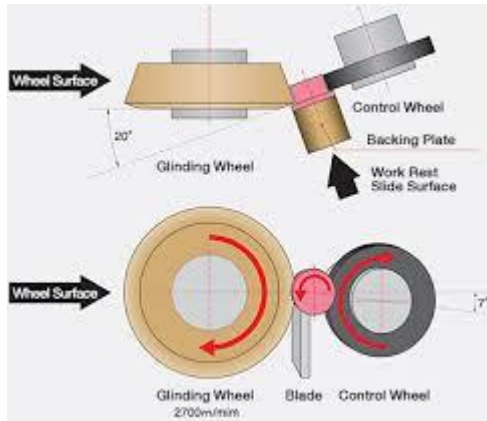

47. Explain In feed grinding.

In feed Grinding:

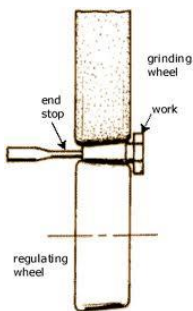

It is similar to plunge or form grinding, the regulating wheel is drawn back so that workpieces may be placed on the work rest blade. Then it is moved into feed the work against the grinding wheel. This method is useful to grind shoulders, and formed surfaces.

48. Write on end feed grinding.

End feed grinding:

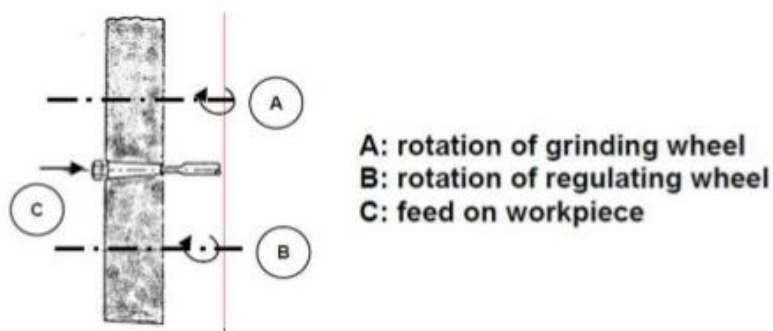

End feed grinding is used to produce taper, either the grinding wheel or regulating wheel or both are formed to a taper. The work is fed lengthwise between the wheels and is ground as it advances until it reaches the end stop.

49. How does the centre less grinding operate.

Centreless grinding operation:

- The centre less grinding operates with two wheels.
- The cutting or grinding wheel, removes excess stock.
- A regulating wheel is used to control the speed of rotation of work
- Rate of feed is controlled by the regulating wheel.

50. Why the centre less grinders is called specialized machine for cylindrical parts?

- Centre less grinders are called specialized machine for cylindrical parts.
- It was developed from the rapid production of cylindrical, external taper or external profile work.

51. What are the advantages of centre less grinding?

The advantages of centre less grinding are:

- a) The work piece is supported through the operations.
- b) No tendency for chatter or deflection of work
- c) Easy control of the size of the work
- d) No need of chucking or mounting.

52. What are the main disadvantages in centre less grinding?

The main disadvantages in centre less grinding are:

- a) In hollow work there is no certainty that the outside diameter will be concentric with the inside diameter.
- b) The work having multiple diameters is not easily handled.

53. Name the special grinding machines.

Many grinding machines are produced to do highly specialized work. Some common types of these machines are the following:

- Roll grinders
- Cam shaft grinders
- Disc grinders
- Crank shaft grinders

54. Write notes on roll grinders.

Roll Grinders:

- Roll grinders are much larger, heavier and more rigid than plain cylindrical grinders.
- They are used to grind and to resurface large steel rolling mill rolls used in basic processing of steel or aluminium and strip, and differ from conventional cylindrical grinders only in their greater than normal dimensional and load carrying capacity.

- In most of the larger roll grinding machines, the wheel head is traversed along the rotating workpieces to accomplish the grinding.

55. What are cam grinders?

These machines are basically cylindrical grinding machines with additional feeding and withdrawal mechanisms for the workpiece. It consists of a separate base that carries the headstock and tailstock. The complete unit can oscillate about a centre below the work pieces. Before carrying out the operation a small template is mounted on the headstock. A hardened steel roller in conjunction with a template actuates the movement of the whole unit to produce the desired shape.

56. What are the types of wheel that are mounted on way grinders?

Types of wheel that are mounted on way grinders:

- Cup more rigid
- Ring
- Segmented wheels

The wheels that are mounted on vertical spindle of a way grinders.

57. Write a short note on disc grinders.

Disc grinders:

- ❖ Disc grinders finish flat surfaces.
- ❖ They remove stock rapidly by grinding with the sides of disc wheels .
- ❖ The disc grinders produce only ordinary tolerance.
- ❖ They have high rates of production.

58. Give the types of disc grinding machines.

Types of disc grinding machines:

There are three standard types of disc grinding machines:

1. Single horizontal spindle
2. Single vertical spindle
3. Double horizontal spindle

The first two are most commonly used for repetitive work by hand operation or with simple fixture. The third is widely used for production operation where parallel surface are ground simultaneously.

59. What are thread grinders?

Thread grinding is basically a generating process, in which the desired thread profile is generated on a solid cylindrical object through grinding. The machines used in this process operate in the principle of cylindrical grinders. These machines carry a lead screw which is connected to

the head stock, much in the same way as in a centre lathe, in order to establish a definite ratio between the speed of rotation of the work and the longitudinal traverse of the grinding wheel, which is given the shape of the thread profile on its face, follows helix angle is provided if the grinding wheel by tilting in spindle to the required angle. But the above process holds good with a single grinding wheel only.

60. Name the work holding and supporting devices used in grinders.

Work holding and supporting devices include:

- a) Steady rest for cylindrical grinders.
- b) Chucks and fixtures for other grinders,
- c) Magnetic chucks used particularly on surface grinders.

61. What are the two types of magnetic chucks?

Types of magnetic chucks:

There are two types of magnetic chucks. They are:

- a) Electromagnetic chuck
- b) Permanent magnetic chuck.

62. What is the use of magnetic chuck in surface grinding?

The magnetic chuck helps in firmly holding the workplace without any distortion due to pressure of the jaws, which is undesirable. Magnetic chuck is used for holding a very thin work piece, made of magnetic material. Moreover more number of similar work piece can be conveniently located on the surface for simultaneous grinding.

63. How are the non-ferrous metals held in magnetic chuck?

- Non-ferrous metals may be held on a magnetic chuck by clamping them in suitable fixtures made of iron or steel by exhausting air from a vacuum chuck.

64. What are the attachments used in grinding machines?

The different attachments are:

- a) Equipments for contour grinding
- b) Attachments to improve grinding results
- c) Measuring and sizing device

65. What is meant by measuring and sizing devices?

The measuring and sizing devices range from simple measuring devices to continuous reading gauge, which actually control the feeding of the machine.

66. What are the attachments used to improve grinding results?

Attachments used to improve grinding results:

- Wheel reciprocating attachments for better finish
- Ultrasonic cleaning devices
- Electrolytic attachments to aid in grinding extremely hard materials.

67. What is meant by dressing of grinding wheels?

Dressing of the grinding wheels:

Dressing of the grinding wheels refer to conditioning the face of the wheel for the operations to be performed ,like opening the face for free cutting, smoothing the face for finishing and removing load from the free face.

This is done by various dressers namely:

- Star dressing tool
- Round (or) Square stick
- Diamond dressing tool
- Crush dressing fixtures

68. What is the difference between truing and dressing of a grinding wheel?

Dressing:

Dressing is the conditioning of the wheel surface which ensures that grit cutting edges are exposed from the bond and thus able to penetrate into the workpiece material. Also, in dressing attempts are made to splinter the abrasive grains to make them sharp and free cutting and also to remove any residue left by material being ground. Dressing therefore produces micro-geometry. The structure of micro-geometry of grinding wheel determine its cutting ability with a wheel of given composition. Dressing can substantially influence the condition of the grinding tool.

Truing:

Truing is the act of regenerating the required geometry on the grinding wheel, whether the geometry is a special form or flat profile. Therefore, truing produces the macro-geometry of the grinding wheel.

Truing is also required on a new conventional wheel to ensure concentricity with specific mounting system. In practice the effective macro-geometry of a grinding wheel is of vital importance and accuracy of the finished workpiece is directly related to effective wheel geometry.

69. How is Dressing on superabrasives wheels done?

Dressing of superabrasive wheel

Dressing of the superabrasive wheel is commonly done with soft conventional abrasive vitrified stick, which relieves the bond without affecting the superabrasive grits. However, modern technique like electrochemical dressing has been successfully used in metal bonded superabrasive wheel. The wheel acts like an anode while a cathode plate is placed in front of the wheel working surface to allow electrochemical dissolution. Electro discharge dressing is another alternative route for dressing metal bonded superabrasive wheel. In this case a dielectric medium is used in place of an electrolyte.

Touch-dressing, a new concept differs from conventional dressing in that bond material is not relieved. In contrast the dressing depth is precisely controlled in micron level to obtain better uniformity of grit height resulting in improvement of workpiece surface finish.

70. Name the truing tools.

There are four major types of truing tools:

- Steel cutter:

These are used to roughly true coarse grit conventional abrasive wheel to ensure freeness of cut.

- Vitrified abrasive stick and wheel:

It is used for off hand truing of conventional abrasive wheel. These are used for truing resin bonded superabrasive wheel.

- Steel or carbide crash roll

It is used to crush-true the profile on vitrified bond grinding wheel.

- Diamond truing tool:

Single point diamond truing tools

Multiple diamond stone truing tool

Impregnated diamond truing tools

71. Write on Diamond form truing tool.

Diamond form truing blocks

Diamond form truing block can be either diamond impregnated metal bond or electroplated, as shown in Fig.28.8. Brazed type diamond truing block has also come as an alternative to electroplated one. They can be as simple as flat piece of metal plated with diamond

to true a straight faced wheel or contain an intricate form to shape the grinding wheel to design profile. Truing block can eliminate the use of self propelled truing wheels and are used almost exclusively for horizontal spindle surface grinder to generate specific form.

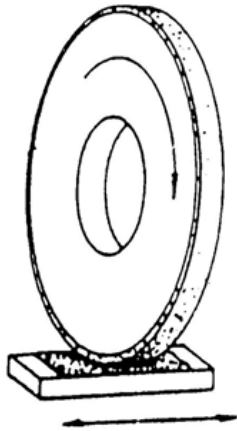

Diamond form truing block to true (a) a straight faced wheel

72. What are the different types of fine finishing process?

Types of fine finishing process:

- Milling
- Super finishing
- Polishing
- Buffing
- Metal spraying
- Galvanizing
- Electroplating

73. What do you mean by loading of grinding wheels? (Nov/ Dec 2006)

Loading of grinding wheels:

During grinding, fine metal chips are removed. These chips adhere to the cutting face.i.e.The gaps between the abrasive particulars are filled up by the chips. “This is called loading. It reduces the cutting capacity of the wheel. Loading may occur due to

1. Slow speed of wheel
2. Grinding of soft metal
3. Taking very deep cut
4. Not using proper coolant.

The loading can be minimized by increasing the speed to the wheel or by using a softer wheel. Loading can be removed by dressing the wheel.

74. Define ‘Glazing’.

Glazing:

The grinding wheel becomes dull or “glazed” after long use. The edges of a glazed take a glass, like appearances. The cutting capacity decreases by using a glazed wheel. When a wheel is too hard or revolved at fast speed, glazing takes place. The glazing can be minimized by selecting lower speed and soften wheel. Glazing can be removed by dressing the wheel.

75. What is honing?(Apr/ May 2012)

Honing is a machining process similar to grinding, used to finish a fine before surface. It is a process of machining with bonded abrasive grains. It serves to improve the shape, size, accuracy and surface quality of the workpiece. One distinguishes between long stroke honing and short stroke honing(superfinishing) in terms of the movement cycles. Both processes can be used for internal surfaces (holes) as well as for outer surfaces(shafts).

76. What is lapping?

Lapping:

In lapping, instead of a bonded abrasive tool, oil-based fluid suspension of very small free abrasive grains (aluminum oxide and silicon carbide, with typical grit sizes between 300 and 600) called a lapping compound is applied between the workpiece and the lapping tool. The lapping tool is called a lap, which is made of soft materials like copper, lead or wood. The lap has the reverse of the desired shape of the workpart. To accomplish the process, the lap is pressed against the work and moved back and forth over the surface in a figure-eight or other motion pattern, subjecting all portions of the surface to the same action. Lapping is sometimes performed by hand, but lapping machines accomplish the process with greater consistency and efficiency.

77. How does honing differ from grinding?

- Grinding machines run at high speeds and pressure, which results in high temperatures.
- But, Honing requires slow speed and low-Pressure, which keeps surface temperature relatively low.

78. What are the materials normally be worked by the Honing process?

Materials worked by honing:

- Steels of all varieties
- Cast iron

- Aluminum, magnesium, brass, bronze.
- Glass, ceramics, hard rubbers, graphite etc., are few examples of honing.
- Honing is mostly used for finishing automobile crank shaft journals.

79. Can CBN be used in honing stick in single layer configuration?

CBN used in honing stick in single layer configuration:

- CBN grits in single layer configuration embedded in galvanic bond can be effectively used as honing stick.
- Such honing stick is preferred in production honing with just a single stroke operation.

80. What is superfinishing?

Superfinishing is a finishing operation similar to honing, but it involves the use of a single abrasive stick. The reciprocating motion of the stick is performed at higher frequency and smaller amplitudes. Also, the grit size and pressures applied on the abrasive stick are smaller. A cutting fluid is used to cool the work surface and wash away chips. In superfinishing, the cutting action terminates by itself when a lubricant film is built up between the tool and work surface.

81. How does superfinishing differ from honing.

Superfinishing, in a way, is similar to honing but with very low cutting pressure and different kinematic tool-work interactions like

- Oscillatory motion of the abrasive stick with short stroke but with high frequency.
- Rotation of workpiece is usually kept low.
- Feed motion of the tool or the work piece.

82. Give the product applications of lapping.

Applications of lapping:

Lapping is done as precision tools, gauges, valves and on other similar places, where resistance to wear of moving parts are needed.

Lapping is done for better sealing characteristics.

It gives longer life of cutting edges.

83. What is meant by polishing?

Polishing:

- Polishing is the surface finishing operation performed by a polishing wheel.
- It is for the purpose of removing appreciable metal

- This process removes the scratches, hole marks, pits and other defects from rough surfaces.

84. How is the polishing wheel made?

Polishing wheel is made of:

- Leather
- Papers
- Canvas
- Muslin
- Felt
- Wool.

The-abrasive grains are set up with the glue or thermosetting, buffing resins on the face of the wheel.

85. Write on electro polishing.

Electro polishing:

Electro polishing is the reverse of electroplating. Here, the workpiece acts as anode and the material is removed from the workpiece by electrochemical dissolution. The process is particularly suitable for polishing irregular surface since there is no mechanical contact between workpiece and polishing medium. The electrolyte electrochemically etches projections on the workpiece surface at a faster rate than the rest, thus producing a smooth surface. This process is also suitable for deburring operation.

86. State the advantage of electro polishing over mechanical polishing.

Electropolishing has clear advantage in polishing irregular surfaces. The electrolyte attacks high points at a faster rate than rest of the surface resulting in production of a smooth surface.

87. How is the surface quality improved in ball burnishing?

In this process, a hardened steel ball presses the workpiece surface. The surface finish is markedly improved. In addition, a residual compressive stress is developed on the surface, which in turn improves the fatigue resistance. The work hardening effect, as a result of burnishing, also enhances wear resistance of the surface. Therefore, by ball burnishing the overall quality of the workpiece surface is significantly improved.

88. What is meant by Buffing?

Buffing:

- Buffing is used to give a much higher, lustrous, reflective finish that cannot be obtained by polishing.

- The buffing process consists of applying a very fine abrasive with a rotating wheel.

89. What are the abrasives and binders used in binding?

Abrasives and binders used in binding:

- Iron oxide
- chromium oxide
- Emery
- wax mixed with grease
- Paraffin's and kerosene are the abrasives and binders used in buffing.

SURFACE INTEGRITY

90. What Does Surface Integrity Mean?

The choice of manufacturing processes is based on cost, time and precision. The precision of a surface is usually based on two criteria: dimensional accuracy and surface roughness. However, another criterion has become increasingly important: the performance of the surface. The term performance has different meanings depending on the context but is mostly linked to fatigue, corrosion, wear and strength. It is usually assumed that performance is directly related to surface texture. The irregularities of the surface, especially valleys or grooves, induce stress concentrations that enable the plastification of the material and crack propagation. As a consequence, a smooth surface limits the risk of crack initiation.

91. How does surface integrity play an important role in this present era?

The aircraft industry was among the first to consider the surface integrity of their pieces, since the consequences of a breakage are always dramatic from a human and economical point of view.

Such an industry has a double objective: designing aircraft with a minimum weight (i.e., with pieces having small sections) and producing pieces with a high degree of safety. Moreover, an additional objective is increasingly becoming important: economical competition, which induces pressure on production costs and obliges factories to produce more rapidly. The combination of these three objectives (thin, fast and safe) makes this job very difficult. Such objectives are also becoming increasingly critical in other industries, such as the automotive industry, because car manufacturers are engaged in a race with two objectives:

- Weight reduction in order to reduce gas consumption,
- increase of engine power in order to satisfy pollution criteria, which leads to increased mechanical stresses that has to be supported by the pieces in the power transmission. Thus the surface integrity of the pieces is of primary importance.

BROACHING MACHINES:

92. What is broaching?

- Broaching is a process of removing metal from a work piece by a cutting tool called broach.
- Broach is a tool having multiple cutting edge arranged along its length.
- The tool may be pulled (or) pushed over a surface on the work piece.
- As the height of the tooth is gradually increasing the metal removed progressively by each tooth.
- The work will be machined in a single pass of the broach.

93. Give some applications of broaching.

Applications of broaching:

By internal broaching-

- Splined holes
- Key ways internal gear serration
- Square and hexagonal holes with different cut are broached.

By surface broaching-

- Flat surface
- Surfaces with different contours
- External splines.

94. What are the advantages of broaching?

Advantages of broaching:

1. The rate of production is very high
2. High accuracy and very good surface finish are obtained
3. Less skilled operator is sufficient
4. Cutting fluid can be effectively applied
5. Both internal and external surfaces can be broached.

95. What are the limitations of broaching?

Limitations of broaching:

(a) Broach is a multipoint cutting tool having multi cutting edges. Preparation of cutting edges is a costly affair. Its initial cost is quite high.

(b) There is a limitation of size of workpiece in case of broaching. Very large sized workpieces cannot be subjected to broaching operation.

(c) Broaching is not possible for the surfaces having obstructions.

(d) Application of broaching is restricted upto finishing and accurate sizing as it can remove only small stocks of material. Removal of larger stocks is not possible in broaching operation.

(e) There is a urgent need of rigid clamping of workpiece in broaching operation to maintain its accuracy and finish. Clamping devices require frequent maintenance and cost.

96. What are the types of broaching machines?

The types of broaching machine are:

1. Horizontal broaching machine
2. Vertical broaching machine
3. Continuous broaching machine

97. How broaches are classified.

Broaches are classified as

1. According to the type of surface broached
 - i) Internal broaches ii) External broaches
2. According to the method of operation
 - i) Push broach ii) Pull broach
3. According to the operations performed on the work piece
 - i) Surface broach ii) Key way broach iii) Round hole broach iv) Spline broach

98. What is meant by push broach?

Push broach:

- A push broach is pushed through the work during cutting.
- During broaching the broach comes under compressive load.
- To avoid bending, the push broach is made short.
- Because of this, only less amount of material is removed by the broach.

99. What is meant by pull broach?

Pull broach:

- A pull broach cuts the material while it is pulled through the work piece.
- During pulling the broach comes under tensile load.
- So it is not bend during machining and so the broach can be made longer.
- More amount of material can be easily removed by the broach.

100. Name some broaching operations.

The broaching operations are

1. Surface broaching,

2. Hole broaching
3. Key way broaching
4. Spline broaching

101. List the various parts of pull type broach.

The various parts of pull type broach are

- 1) Pull end 2) Front pilot 3) Roughing and semi finishing teeth
- 4) Finishing teeth 5) Rear pilot 6) Land 7) Clearance angle
- 8) Rake (or) face angle 9) Pitch

102. Why broaching process is long and laborious?

Broaching process is long and laborious because

1. The shape of the broach is complicated
2. Each tooth of the broach has different dimensions.

16 MARKS QUESTIONS ANS ANSWERS

1. Briefly explain Surface grinding machines and their types.(16)

Basically there are four different types of surface grinding machines characterized by the movement of their tables and the orientation of grinding wheel spindles as follows:

- Horizontal spindle and reciprocating table
- Vertical spindle and reciprocating table
- Horizontal spindle and rotary table
- Vertical spindle and rotary table

Horizontal spindle reciprocating table grinder

This machine with various motions required for grinding action. A disc type grinding wheel performs the grinding action with its peripheral surface. Both traverse and plunge grinding can be carried out in this machine.

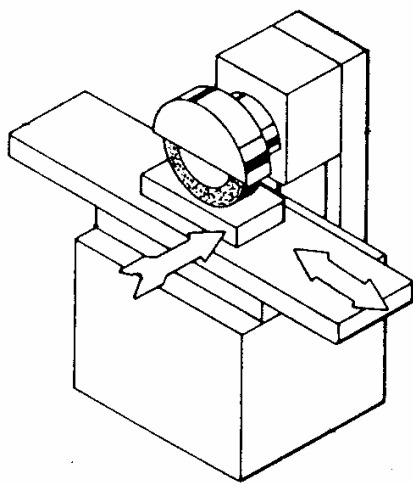

- A: rotation of grinding wheel**
- B: reciprocation of worktable**
- C: transverse feed**
- D: down feed**

Horizontal spindle reciprocating table surface grinder

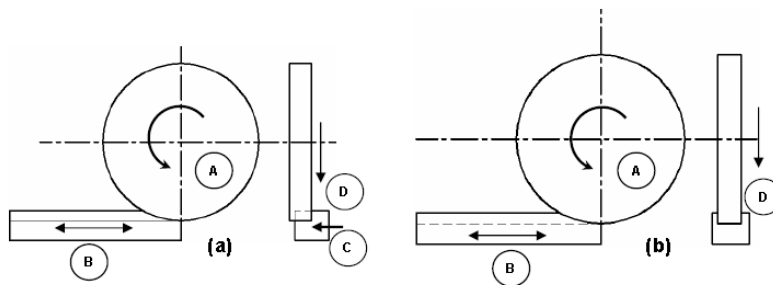

- A: rotation of grinding wheel**
- B: reciprocation of worktable**
- C: transverse feed**
- D: down feed**

Surface grinding (a) traverse grinding (b) plunge grinding

Vertical spindle reciprocating table grinder

The grinding operation is similar to that of face milling on a vertical milling machine. In this machine a cup shaped wheel grinds the workpiece over its full width using end face of the wheel. This brings more grits in action at the same time and consequently a higher material removal rate may be attained than for grinding with a peripheral wheel.

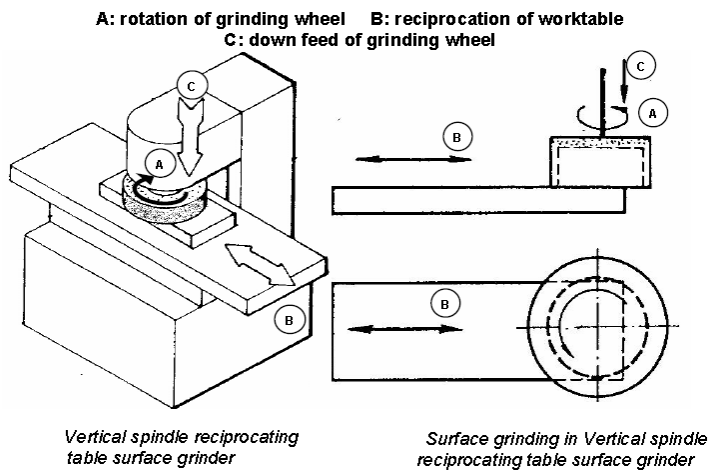

Horizontal spindle rotary table grinder

In principle the operation is same as that for facing on the lathe. This machine has a limitation in accommodation of workpiece and therefore does not have wide spread use. However, by swivelling the worktable, concave or convex or tapered surface can be produced on individual part.

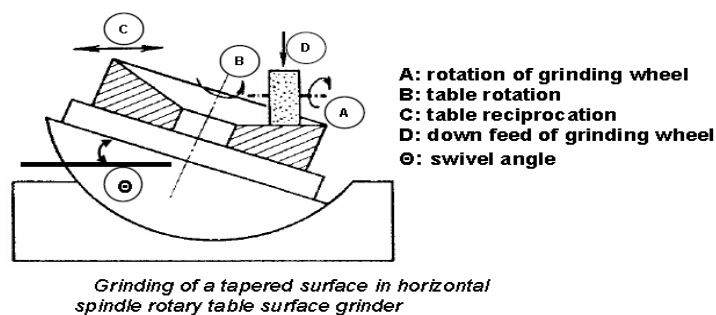
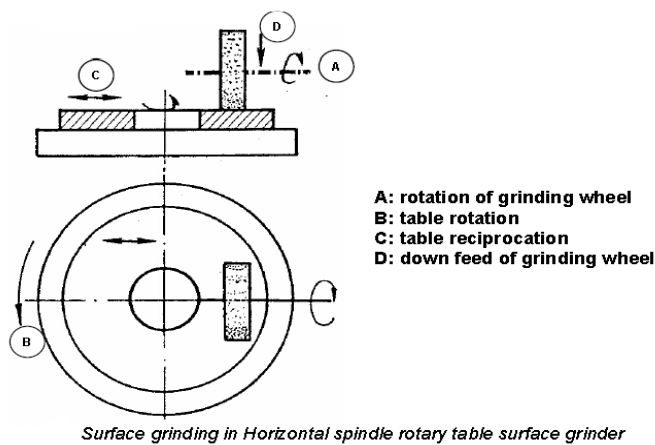

Vertical spindle rotary table grinder

The machine is mostly suitable for small workpieces in large quantities. This primarily production type machine often uses two or more grinding heads thus enabling both roughing and finishing in one rotation of the work table.

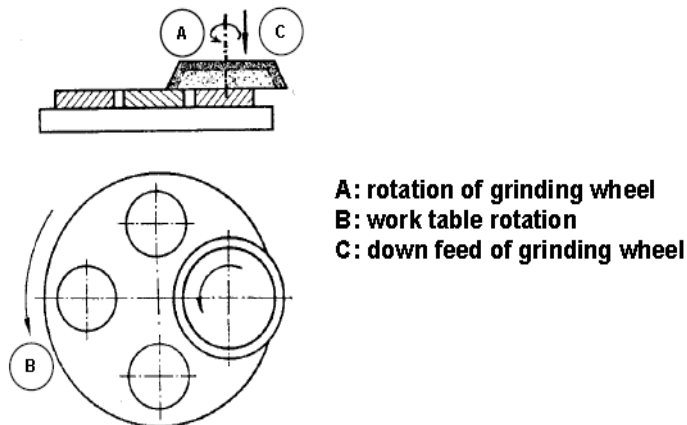

Surface grinding in vertical spindle rotary table surface grinder

2. Discuss Various Bonding Materials Used For Making Grinding Wheels.(Apr/ May13)

Two types of abrasives are used in grinding wheels: natural and manufactured. Except for diamonds, manufactured abrasives have almost entirely replaced natural abrasive materials. Even natural diamonds have been replaced in some instances by synthetic diamonds. The manufactured abrasives most commonly used in grinding wheels are aluminum oxide, silicon carbide, cubic boron nitride, and diamond.

Aluminum oxide: Refining bauxite ore in an electric furnace makes aluminum oxide. The bauxite ore is heated to eliminate moisture and then mixed with coke and iron to form a furnace charge. The mixture is then fused and cooled.

- The fused mixture resembles a rocklike mass. It is washed, crushed and screened to separate the various grain sizes. Aluminum oxide wheels are manufactured with abrasives of different degrees of purity to give them certain characteristics for different grinding operations and applications. The colour and toughness of the wheel are influenced by the degree of purity.
- General-purpose aluminum oxide wheels, usually gray and 95 percent pure are the most popular abrasives used. They are used for grinding most steels and other ferrous alloys. They are used for grinding most steels and other ferrous alloys. White aluminum oxide wheels are nearly pure and are very friable (able to break away from the material easily.) They are used for grinding high-strength, heat-sensitive steels.

Silicon carbide: Silicon carbide grinding wheels are made by mixing pure white quartz, petroleum coke and small amounts of sawdust and salt, and then by firing the mixture in an electric furnace. The process is called synthesizing the coke and sand. As in the making of aluminum oxide abrasive, the resulting crystalline mass is crushed and graded by particle size.

- Silicon carbide wheels are harder and more brittle than aluminum oxide wheels. There are two principal types of silicon carbide wheels: black and green.
- Black wheels are used for grinding cast irons, non-ferrous metals like copper, brass, aluminum, and magnesium, and non-metallic such as ceramics and gemstones. Green silicon carbide wheels are more friable than the black wheels and used for tool and cutter grinding of cemented carbide.

Cubic boron nitride (CBN): Cubic boron nitride is an extremely hard, sharp and cool cutting abrasive. It is one of the newest manufactured abrasives and 2.5 times harder than aluminum oxide. It can withstand temperatures up to 2,500°F.

- CBN is produced by high-temperature, high-pressure processes similar to those used to produce manufactured diamond and is nearly as hard as diamond. CBN is used for grinding super-hard, high-speed steels, tool and die steels, hardened cast irons, and stainless steels.
- Two types of cubic boron nitride wheels are used in industry today. One type is metal-coated to promote good bond adhesion and used in general purpose grinding. The second type is an uncoated abrasive for use in electroplated metal and vitrified bond systems.

Diamond: Two types of diamond are used in the production of grinding wheels: natural and manufactured. Natural diamond is a crystalline form of carbon, and very expensive.

- In the form of bonded wheels, natural diamonds are used for grinding very hard materials such as cemented carbides, marble, granite and stone. Recent developments in the production of manufactured diamonds have brought their cost down and led to expanded use.
- Manufactured diamonds are now used for grinding tough and very hard steels, cemented carbide and aluminum oxide cutting tools.

3. Explain types of bonding materials used in grinding wheel manufacturing.(Apr/ May 2012).

Abrasive grains are held together in a grinding wheel by a bonding material. The bonding material does not cut during grinding operation. Its main function is to hold the grains together with varying degrees of strength. Standard grinding wheel bonds are vitrified, resinoid, silicate, shellac, rubber and metal.

Vitrified bond: Vitrified bonds are used on more than 75 percent of all grinding wheels. Vitrified bond material is comprised of finely ground clay and fluxes with which the abrasive is thoroughly

mixed. The mixture of bonding agent and abrasive in the form of a wheel is then heated to 2,400°F to fuse the materials.

- Vitrified wheels are strong and rigid. They retain high strength at elevated temperatures and are practically unaffected by water, oils or acids.
- One disadvantage is that they exhibit poor shock resistance. Therefore, their application is limited where impact and large temperature differentials occur.

Resinoid bond: Resinoid bonded grinding wheels are second in popularity to vitrified wheels. Phenolic resin in powdered or liquid form is mixed with the abrasive grains in a form and cured at about 360F. Resinoid wheels are used for grinding speeds up to 16,500 SFPM. Their main use is in rough grinding and cut-off operations.

Silicate bond: This bonding material is used when heat generated by grinding must be kept to a minimum. Silicate bonding material releases the abrasive grains more readily than other types of bonding agents. Speed is limited to below 4,500 SFPM.

Shellac bond: It's an organic bond used for grinding wheels that produce very smooth finishes on parts such as rolls, cutlery, camshafts and crankpins. Generally, they are not used on heavy-duty grinding operations.

Rubber bond: Rubber-bonded wheels are extremely tough and strong. Their principal uses are as thin cut-off wheels and driving wheels in centerless grinding machines. They are used also when extremely fine finishes are required on bearing surfaces.

Metal bond: Metal bonds are used primarily as binding agents for diamond abrasives. They are also used in electrolytic grinding where the bond must be electrically conductive.

4. Briefly explain Honing process and mention their advantage and applications.(Nov/ Dec 2013)

How honing works

The abrasive action of the honing tool removes material from the workpiece's inside diameter. The tool rotates and expands while the workpiece reciprocates (stroking) back and forth. For example, tolerances of 0.003mm (0.0001") round and straight can be achieved in production using special fixturing. To achieve such close tolerances, the workpiece must be allowed to "float" or move in three axes.

Honing is a finishing process, in which a tool called hone carries out a combined rotary and reciprocating motion while the workpiece does not perform any working motion. Most honing is done on internal cylindrical surface, such as automobile cylindrical walls. The honing stones are held

against the workpiece with controlled light pressure. The honing head is not guided externally but, instead, floats in the hole, being guided by the work surface. It is desired that

1. Honing stones should not leave the work surface
2. Stroke length must cover the entire work length.

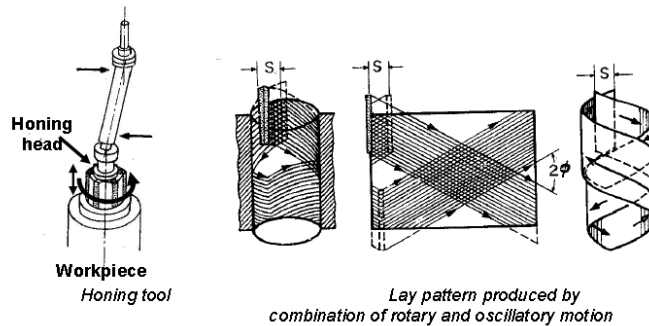

The honing stones are given a complex motion so as to prevent every single grit from repeating its path over the work surface. The critical process parameters are:

1. Rotation speed
2. Oscillation speed
3. Length and position of the stroke
4. Honing stick pressure

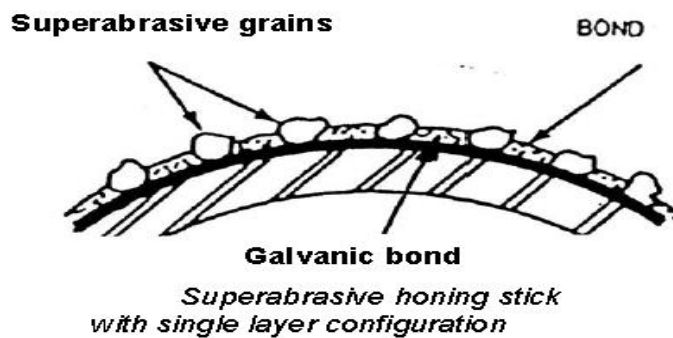

With the advent of precision brazing technique, efforts can be made to manufacture honing stick with single layer configuration with a brazed metal bond. Like brazed grinding wheel such single layer brazed honing stick are expected to provide controlled grit density, larger grit protrusion leading to higher material removal rate and longer life compared to what can be obtained with a galvanically bonded counterpart.

The important parameters that affect material removal rate (MRR) and surface roughness (R) are:

- (i) Unit pressure, p

(ii) Peripheral honing speed, V_c

(iii) Honing time, T

The variation of MRR (Q) and R with unit pressure is shown in Fig. 30.12. It is evident from the graph that the unit pressure should be selected so as to get minimum surface roughness with highest possible MRR.

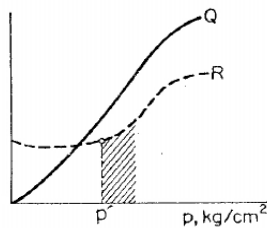

Effect of honing pressure on MRR and surface finish

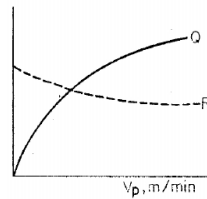

Effect of peripheral honing speed

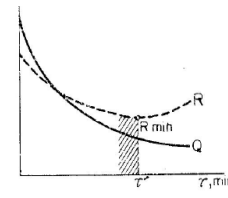

Effect of honing time on material removal rate and surface roughness

Application

- ⇒ The honing process is used to obtain precise dimensions and surfaces in cylindrical shapes with a wide range of diameters.
- ⇒ This applies to parts such as Hydraulic Cylinders, Pistons, Bearing Bores, Pin Holes and to some external cylindrical surfaces.

Advantage

- ⇒ The honing process offers advantages of low capital equipment cost,
- ⇒ High metal removal rates, and extreme accuracy of 0.001mm (0.00004") in a wide variety of materials.
- ⇒ The ability to create round and straight bores in relatively long workpieces. Workpiece bore length-to-diameter ratios of 1.5:1 and longer are ideal for the process.
- ⇒ Shorter bore lengths can be accommodated by stacking workpieces in special fixturing.
- ⇒ Honing can correct parts that are not square, within limits. Understanding the abilities of honing to correct out-of-squareness requires an explanation of the principles of honing.

5. Briefly Explain Cylindrical grinding machines in detail. (Nov/ Dec2010)

- ⇒ In Cylindrical grinding operation, the external or internal cylindrical surface of a work piece is ground. In external cylindrical grinding (also center-type grinding) the workpiece rotates and reciprocates along its axis, although for large and long work parts the grinding wheel reciprocates.

⇒ In internal cylindrical grinding, a small wheel grinds the inside diameter of the part. The workpiece is held in a rotating chuck in the headstock and the wheel rotates at very high rotational speed. In this operation, the workpiece rotates and the grinding wheel reciprocates.

⇒ This machine is used to produce external cylindrical surface. The surfaces may be straight, tapered, steps or profiled. Broadly there are three different types of cylindrical grinding machine as follows:

1. Plain centre type cylindrical grinder
2. Universal cylindrical surface grinder
3. Centreless cylindrical surface grinder

Plain centre type cylindrical grinder

The machine is similar to a centre lathe in many respects. The workpiece is held between head stock and tailstock centres. A disc type grinding wheel performs the grinding action with its peripheral surface.

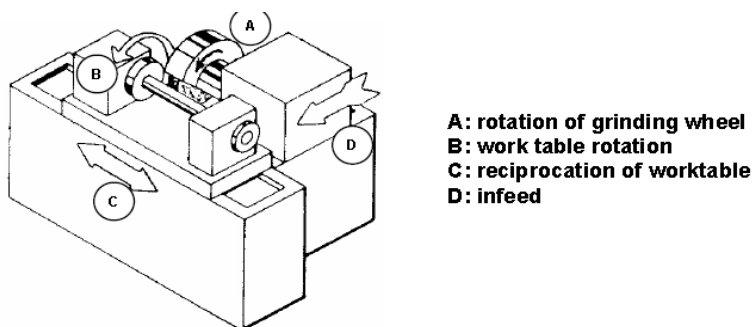

Plain centre type cylindrical grinder

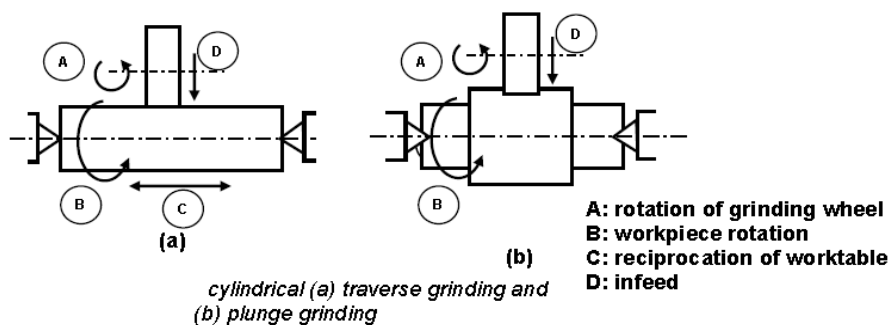

Universal cylindrical surface grinder

Universal cylindrical grinder is similar to a plain cylindrical one except that it is more versatile. In addition to small worktable swivel, this machine provides large swivel of head stock, wheel head slide and wheel head mount on the wheel head slide.

This allows grinding of any taper on the workpiece. Universal grinder is also equipped with an additional head for internal grinding. Schematic illustration of important features of this machine is shown in Fig.

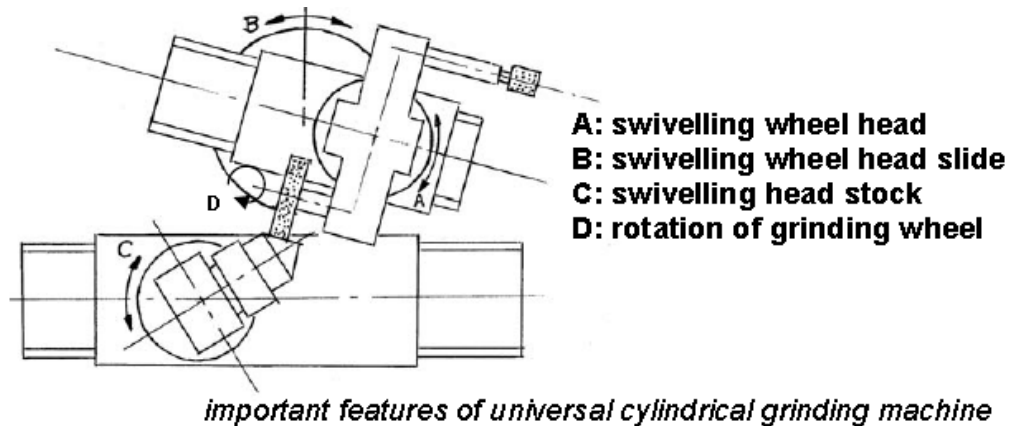

Special application of cylindrical grinder

Principle of cylindrical grinding is being used for thread grinding with specially formed wheel that matches the thread profile. A single ribbed wheel or a multi ribbed wheel can be used .

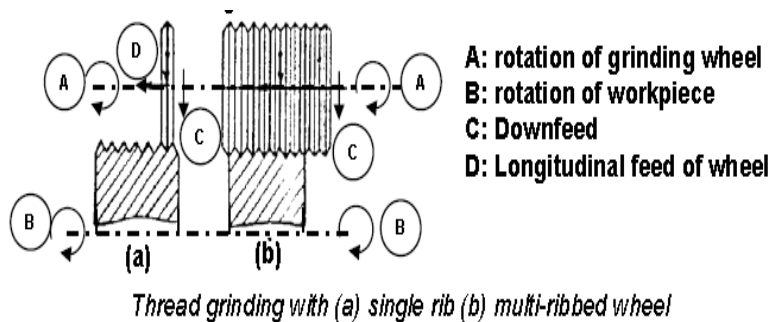

Roll grinding is a specific case of cylindrical grinding wherein large work pieces such as shafts, spindles and rolls are ground.

Crankshaft or crank pin grinders also resemble cylindrical grinder but are engaged to grind crank pins which are eccentric from the centre line of the shaft as shown in below. The eccentricity is obtained by the use of special chuck.

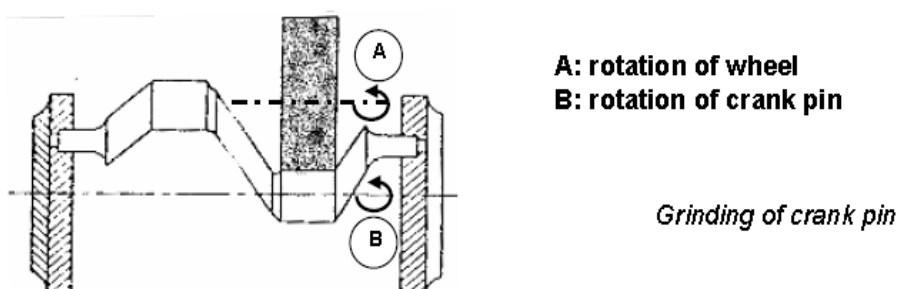

Cam and camshaft grinders are essentially subsets of cylindrical grinding machine dedicated to finish various profiles on disc cams and cam shafts. The desired contour on the workpiece is generated by varying the distance between wheel and workpiece axes.

The cradle carrying the head stock and tail stock is provided with rocking motion derived from the rotation of a master cam that rotates in synchronization with the workpiece. Newer machines however, use CNC in place of master cam to generate cam on the workpiece.

External centreless grinder

This grinding machine is a production machine in which outside diameter of the workpiece is ground. The work piece is not held between centres but by a work support blade. It is rotated by means of a regulating wheel and ground by the grinding wheel.

In through-feed centreless grinding, the regulating wheel revolving at a much lower surface speed than grinding wheel controls the rotation and longitudinal motion of the workpiece. The regulating wheel is kept slightly inclined to the axis of the grinding wheel and the workpiece is fed longitudinally.

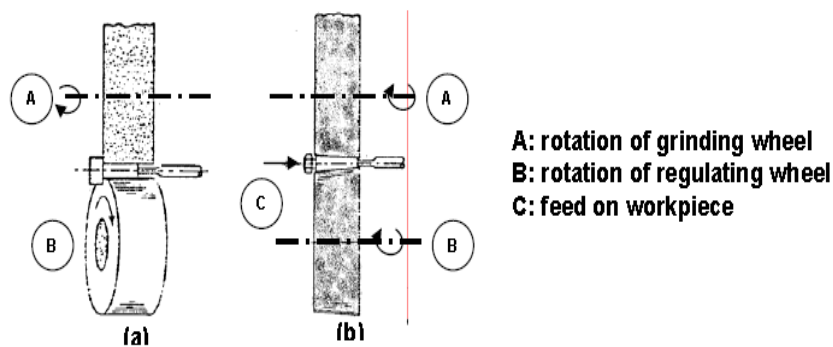

Centreless (a) infeed and (b) end feed grinding

Parts with variable diameter can be ground by Centre lessin feed grinding as shown in Fig (a). The operation is similar to plunge grinding with cylindrical grinder.

6. List out the advantages and dis advantages of centerless grinding machine.

Advantages

- ⇒ The work supported throughout the entire length. So, there is no chatter or deflection.
- ⇒ Size of the wheel is easily controlled by the regulating wheel.
- ⇒ A wide range of components can be ground.
- ⇒ A very little skill is required to operate the machine.
- ⇒ Work holding devices are not required.

Disadvantages

- ⇒ Work with flat and key ways are not ground.
- ⇒ Work with step and multiple diameters cannot be ground.

7. Briefly Explain types internal grinding machine.

This machine is used to produce an internal cylindrical surface. The surface may be straight, tapered, grooved or profiled.

Broadly there are three different types of internal grinding machine as follows:

1. Chucking type internal grinder
2. Planetary internal grinder
3. Centreless internal grinder

Chucking type internal grinder

Chucking type internal grinding machine and various motions required for grinding action. The workpiece is usually mounted in a chuck. A magnetic face plate can also be used. A small grinding wheel performs the necessary grinding with its peripheral surface.

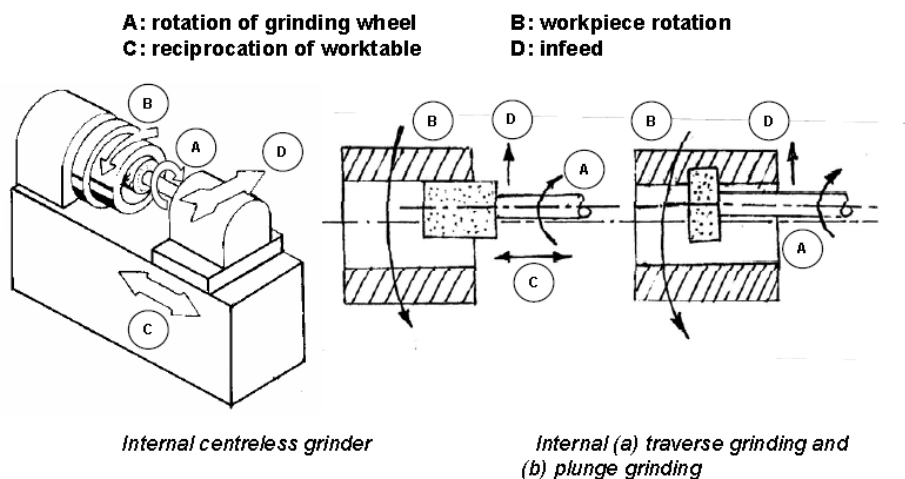

Centreless internal grinder

This machine is used for grinding cylindrical and tapered holes in cylindrical parts (e.g. cylindrical liners, various bushings etc). The workpiece is rotated between supporting roll, pressure roll and regulating wheel and is ground by the grinding wheel.

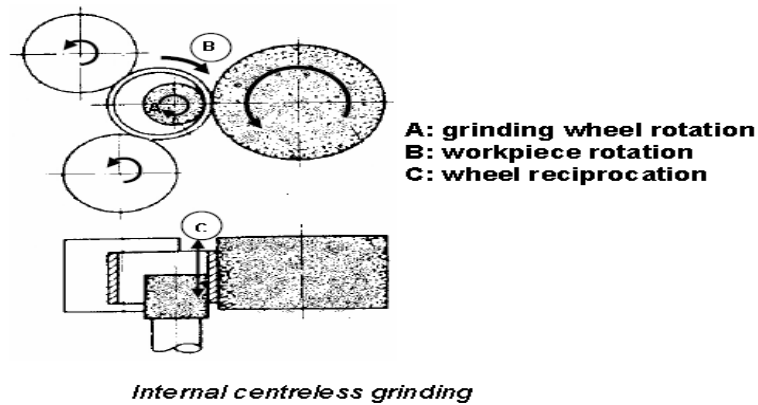

8. What is meant by dressing and truing of the grinding wheel?

Truing:

- ⇒ Truing is the act of regenerating the required geometry on the grinding wheel, whether the geometry is a special form or flat profile. Therefore, truing produces the macro-geometry of the grinding wheel.
- ⇒ Truing is also required on a new conventional wheel to ensure concentricity with specific mounting system.
- ⇒ In practice the effective macro-geometry of a grinding wheel is of vital importance and accuracy of the finished workpiece is directly related to effective wheel geometry.

Dressing:

- ⇒ Dressing is the conditioning of the wheel surface which ensures that grit cutting edges are exposed from the bond and thus able to penetrate into the workpiece material. Also, in dressing attempts are made to splinter the abrasive grains to make them sharp and free cutting and also to remove any residue left by material being ground.
- ⇒ Dressing therefore produces micro-geometry. The structure of micro geometry of grinding wheel determine its cutting ability with a wheel of given composition. Dressing can substantially influence the condition of the grinding tool.
- ⇒ Truing and dressing are commonly combined into one operation for conventional abrasive grinding wheels, but are usually two distinctly separate operation for super abrasive wheel.
- ⇒ Dressing of super abrasive wheel dressing of the super abrasive wheel is commonly done with soft conventional abrasive vitrified stick, which relieves the bond without affecting the super abrasive grits.

- ⇒ However, modern technique like electrochemical dressing has been successfully used in metal bonded super abrasive wheel. The wheel acts like an anode while a cathode plate is placed in front of the wheel working surface to allow electrochemical dissolution.
- ⇒ Electro discharge dressing is another alternative route for dressing metal bonded super abrasive wheel. In this case a dielectric medium is used in place of an electrolyte. Touch-dressing, a new concept differs from conventional dressing in that bond material is not relieved.
- ⇒ In contrast the dressing depth is precisely controlled in micron level to obtain better uniformity of grit height resulting in improvement of work piece surface finish.

9. List out and explain the performance of grinding wheel based on types of abrasive materials.

Grit size the grain size affects material removal rate and the surface quality of workpiece in grinding. Large grit- big grinding capacity, rough workpiece surface Fine grit- small grinding capacity, smooth workpiece surface

Grade The worn out grit must pull out from the bond and make room for fresh sharp grit in order to avoid excessive rise of grinding force and temperature. Therefore, a soft grade should be chosen for grinding hard material. On the other hand, during grinding of low strength soft material grit does not wear out so quickly. Therefore, the grit can be held with strong bond so that premature grit dislodgement can be avoided.

Structure / concentration- The structure should be open for grinding wheels engaged in high material removal to provide chip accommodation space. The space between the grits also serves as pocket for holding grinding fluid. On the other hand dense structured wheels are used for longer wheel life, for holding precision forms and profiles.

Bond

Vitrified bond Vitrified bond is suitable for high stock removal even at dry condition. It can also be safely used in wet grinding. It cannot be used where mechanical impact or thermal variations are like to occur. This bond is also not recommended for very high speed grinding because of possible breakage of the bond under centrifugal force.

Resin bond Conventional abrasive resin bonded wheels are widely used for heavy duty grinding because of their ability to withstand shock load. This bond is also known for its vibration absorbing characteristics and finds its use with diamond and CBN in grinding of cemented carbide and steel

respectively. Resin bond is not recommended with alkaline grinding fluid for a possible chemical attack leading to bond weakening. Fiberglass reinforced resin bond is used with cut off wheels which requires added strength under high speed operation.

Shellac bond At one time this bond was used for flexible cut off wheels. At present use of shellac bond is limited to grinding wheels engaged in fine finish of rolls.

Oxychloride bond: It is less common type bond, but still can be used in disc grinding operation. It is used under dry condition.

10. What are the Merits and Demerits of Broaching operation?

Broaching is widely used for faster finishing operations in metal working so it is a fit case for mass production. Merits and demerits of broaching operations are described below.

- ⇒ It gives high rate of production so recommended for mass production.
- ⇒ Production run time in case of broaching is very large as a broach has very long life. The whole processing load is shared by so many teeth.
- ⇒ Due to faster operation and longer tool life, it is relatively cheaper.
- ⇒ Both rough cutting as well as finished cutting can be completed in a single pairs of tool.
- ⇒ Little skill or employment of semi-skilled manpower is sufficient to perform broaching operation.
- ⇒ Broaching provides accurate and excellent quality of surface finish. It is capable to maintain tolerance of the order of 0.007 mm and surface finish CLA value upto 0.8mm.
- ⇒ It is also capable to process internal and external surface including intricate shaped cavities.
- ⇒ Broaching makes the effective use of cutting fluids as it facilitates the flow of cutting fluid into the cuts.

In addition to the above merits the operation of broaching has some demerits, which are described below:

- Broach is a multipoint cutting tool having multi cutting edges. Preparation of cutting edges is a costly affair. Its initial cost is quite high.
- There is a limitation of size of workpiece in case of broaching. Very large sized work pieces cannot be subjected to broaching operation.
- Broaching is not possible for the surfaces having obstructions.
- Application of broaching is restricted upto finishing and accurate sizing as it can remove only small stocks of material. Removal of larger stocks is not possible in broaching operation.
- There is an urgent need of rigid clamping of workpiece in broaching operation to maintain its accuracy and finish. Clamping devices require frequent maintenance and cost.

11. Discuss (A) broaching operation,(B) mention their objective, (C)Sketch the shapes prepare by the internal broaching.

- Before understanding the process of broaching and the related machining tools it is required to know the clear difference between single point and multipoint cutting tool.
- A single point cutting tool normally consists of a single cutting point or an edge used for cutting.
- The example of single point cutting tool is turning tool used for turning tool is generally has more than one cutting points or cutting edges in action at a time. Example of multipoint cutting tool is milling cutter or a broaching tool.
- Broaching is one of the metal machining operations done by a multipoint cutting tool called broaching tool or broach. The tool is made reciprocating linearly relative to the workpiece in the direction of tool axis.
- The relative movement, necessary fixtures for workpiece and the broach are provided by a machine tool called broaching machine. The broaching is a high productivity method as so many cutting edges work to machine the workpiece at a time.
- The tool may be pulled or pushed through the surfaces to be finished. Surfaces finished by broaching either internal or external.
- External broaching is performed on the outside surface of the workpiece to create a pre-decided shape with dimensional accuracy and high degree of surface finish. Internal broaching is done on the internal surfaces of the workpieces. This way internal surfaces are brought to exact size with the required surface finish.

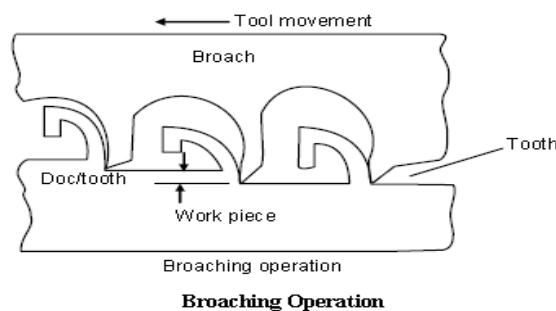

Objectives

After studying this unit, you should be able to understand

- Know broaching operation, machining operation,
- Understand about broach and various types of broaching tools,
- Know main parts of a broach,
- Know the different types of broaches,

- Describe the broaching methods as different broaching operations,
- The merits and demerits of broaching operations,
- Know about broaching machine and its operation, and
- Classifications of broaching machines.

Shapes prepare by the internal broaching

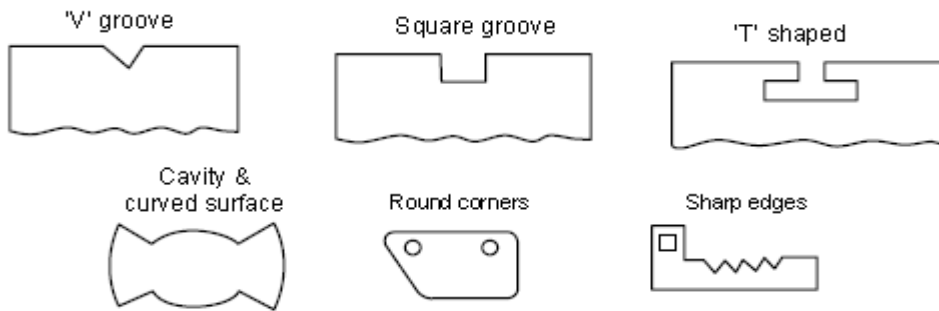

Shapes Prepared by Internal Broaching

12. Explain the nomenclature of broaching tool.

- As we know that the broach is a broaching tool, it consists of a series of distinct cutting edges called cutting teeth along its length. Feed is accomplished by the increased step between any two successive teeth on the broach.
- The total material removed in a single pairs of the broach is the cumulative result of all the teeth in the tool in action (it is not necessary that all the teeth available in the broach in action at a time). The cutting speed of the broach is decided by the linear travel of the tool with respect to the workpiece.
- The shape of the cut surface (machined surface) is determined by the contour of the cutting edges on the broach. Generally broaches are made of high speed steel (HSS).
- In some cases the broaches are made of cast iron and their cutting edges are made of cemented carbide inserts. These inserts are fastened to the right place by mechanical means or brazed.

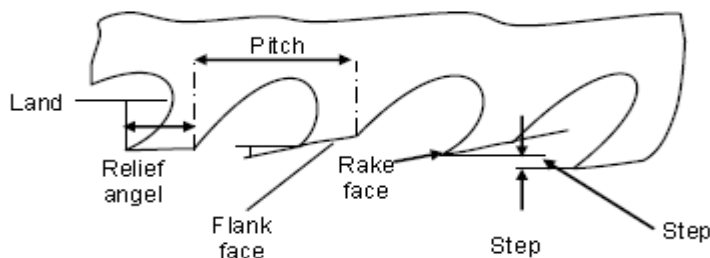

Broach nomenclature

Nomenclature of broach if expressed with its numerical values, called specification of broach. This nomenclature is explained below.

Pull End

Pull end is made to attach the broach to the broaching machine through the puller head.

Front Pilot

This centers the broach in the hole to be finished just before start of processing.

Roughing Teeth

These are the cutting edges which remove larger amount of stocks during cutting. Larger amount removal generates poor quality of surface finish but makes the operation faster.

Finishing Teeth

These are cutting edges removing smaller stocks of material. These are used for final finishing of the surfaces and their accurate sizing.

Rear Pilot and Follower Rest

This is a supporting device to the broach when it is likely to complete its operation of broaching.

Land

It is the width of flank face of the broach normally it is kept slightly inclined to give relief angle to the flank face of broach.

Pitch

It is the distance between two corresponding points on two successive teeth of a broach. Normally pitch of finishing teeth of a broach is kept comparatively smaller than the rough cutting teeth.

Height of the Teeth

Height of the roughing and finishing teeth gradually increases from the shank to the finishing teeth. This increment is called the cut per tooth, it depends on the material being machined. Normally the cut per tooth is taken from 0.01 or 0.2 mm for the finishing teeth and it may go up 0.2 mm for the cutting teeth.

(b)Discuss Super Finishing Operation.(8)

- The super finishing end-face of a cylindrical workpiece. In this both feeding and oscillation of the super finishing stone is given in the radial direction.
- The super finishing operation in plunge mode. In this case the abrasive stone covers the section of the work piece requiring super finish. The abrasive stone is slowly fed in radial direction while its oscillation is imparted in the axial direction.

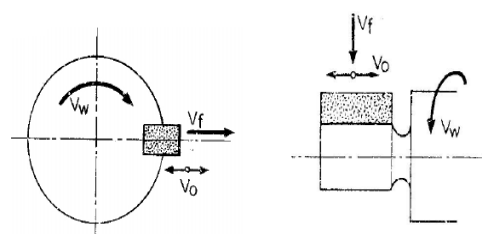

*superfinishing of end face
of a cylindrical work piece in radial mode*

*superfinishing operation in
plunge mode*

Super finishing can be effectively done on a stationary workpiece. In this the abrasive stones are held in a disc which oscillates and rotates about the axis of the work piece. The internal cylindrical surfaces can also be super finished by axially oscillating and reciprocating the stones on a rotating workpiece.

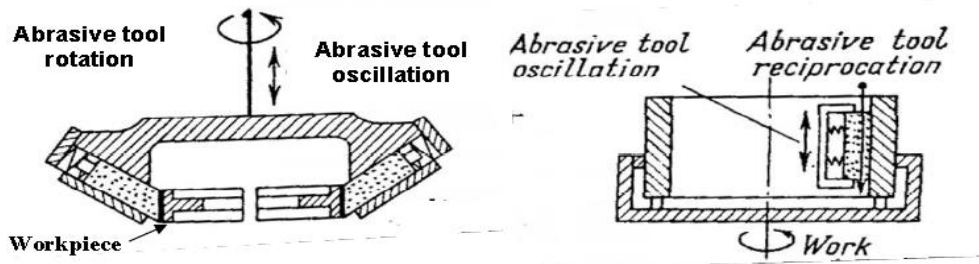

13. Explain Different types of Broaches and their applications.(16)

Broaching is getting more and more widely used, wherever feasible, for high productivity as well as product quality. Various types of broaches have been developed and are used for wide range of applications.

Broaches can be broadly classified in several aspects such as,

- ❖ Internal broaching or external broaching
- ❖ Pull type or Push type
- ❖ Ordinary cut or Progressive type
- ❖ Solid, Sectional or Modular type
- ❖ Profile sharpened or form relieved type

Internal broaching tools are used to enlarge and finish various contours in through holes preformed by casting, forging, rolling, drilling, punching etc. Internal broaching tools are mostly pull type but may be push type also for lighter work. Pull type internal broaching tools are generally provided with

a set of roughing teeth followed by few semi-finishing teeth and then some finishing teeth which may also include a few burnishing teeth at the end.

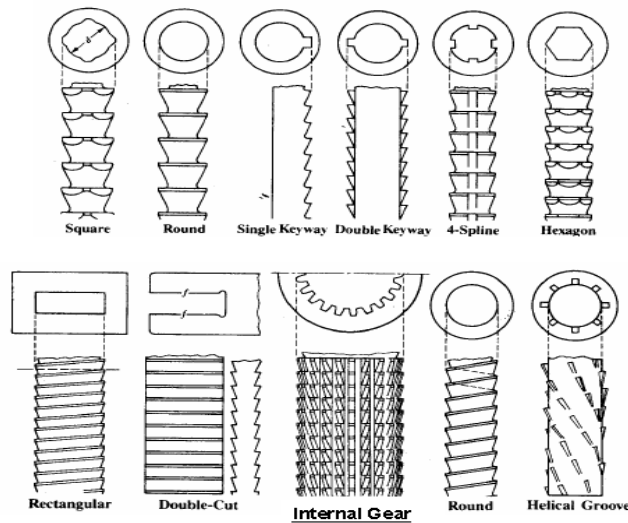

Internal broaching – tools and applications.

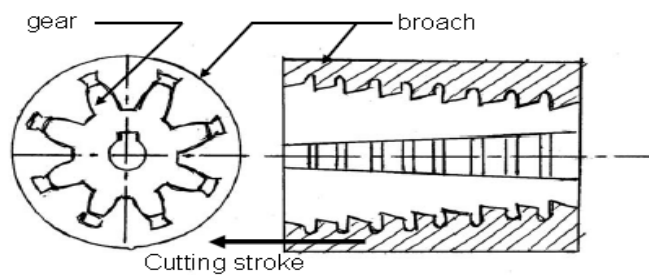

Machining external gear teeth by broaching.

External broaching

External surface broaching competes with milling, shaping and planing and, wherever feasible, outperforms those processes in respect of productivity and product quality. External broaching tools may be both pull and push type.

Major applications of external broaching are:

- Un-obstructed outside surfacing; flat, peripheral and contour surfaces o grooves, slots, keyways etc.
- External splines of different forms

External broaching tools are often made in segments which are clamped in fixtures for operation.

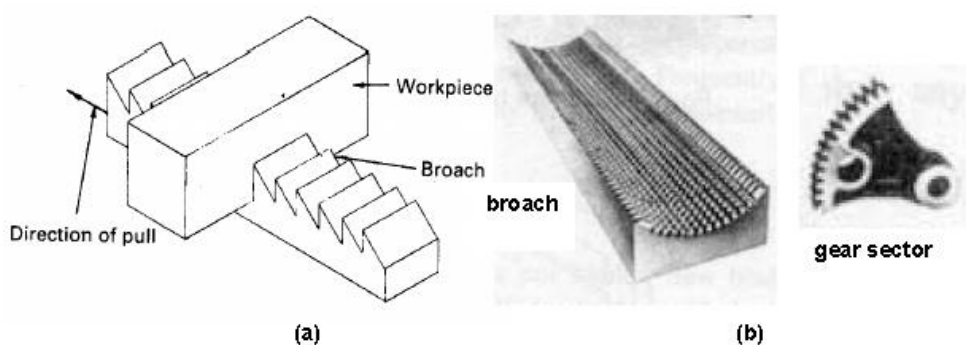

Typical external broaching (a) making slot (b) teeth of gear sector

Pull type and push type broaches

- During operation a pull type broach is subjected to tensile force, which helps in maintaining alignment and prevents buckling.
- Pull type broaches are generally made as a long single piece and are more widely used, for internal broaching in particular. Push type broaches are essentially shorter in length (to avoid buckling) and may be made in segments.
- Push type broaches are generally used for external broaching, preferably, requiring light cuts and small depth of material removal.

Ordinary – cut and Progressive type broach

- Most of the broaches fall under the category of Ordinary – cut type where the teeth increase in height or protrusion gradually from tooth to tooth along the length of the broach.
- By such broaches, work material is removed in thin layers over the complete form. Whereas, Progressive – cut type broaches have their teeth increasing in width instead of height.

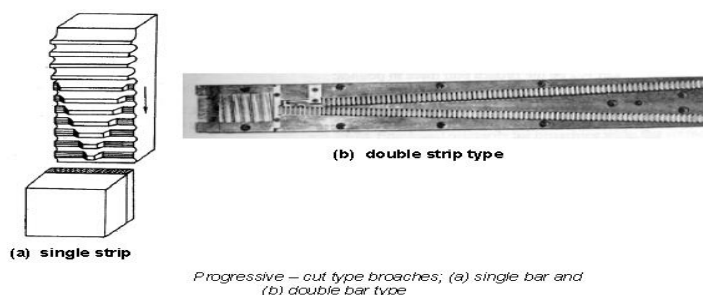

Solid, Sectional and module type broaches

- Broaches are mostly made in single pieces especially those used for pull type internal broaching. But some broaches called sectional broaches, are made by assembling several sections or cutter-pieces in series for convenience in manufacturing and resharpenering and also for having little flexibility required by production in batches having interbatch slight job variation.
- External broaches are often made by combining a number of modules or segments for ease of manufacturing and handling.

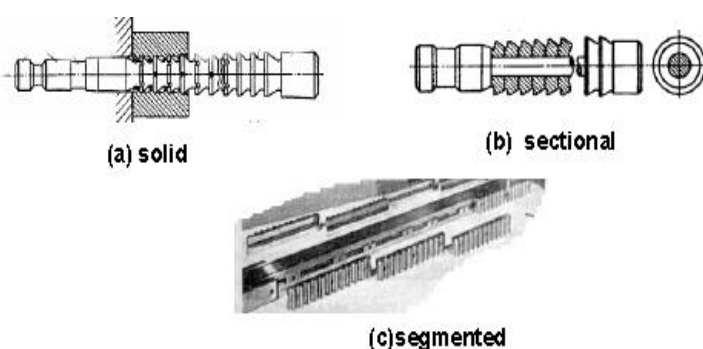

(a) Solid, (b) Sectional and (c) Segmented broaches.

Profile sharpened and form relieved type broaches

Like milling cutters, broaches can also be classified as

➤ **Profile sharpened type broaches;**

Such cutters have teeth of simple geometry with same rake and clearance angles all over the cutting edge. These broaches are generally designed and used for machining flat surface(s) or circular holes.

➤ **Form relieved type broaches**

These broaches, being used for non-uniform profiles like gear teeth etc., have teeth where the cutting edge geometry is more complex and varies point – to – point along the cutting edges. Here the job profile becomes the replica of the tool form. Such broaches are sharpened and resharpener by grinding at their rake faces unlike the profile sharpened broaches which are ground at the flank surfaces.

14. With neat sketch explain the working principle of vertical Broaching machine.

- Vertical broaching machines can be designed for push broaching, pull-down broaching, and pull-up broaching or surface broaching. Push broaching machines are similar to an arbor press with a guided ram; typical capacities are 5 to 50 tons.
- The two ram pull-down machine is the most common type of broaching machine. This style machine has the rams under the table. Pull-up machines have the ram above the table; they usually have more than one ram. Most surface broaching is done on a vertical machine.
- Broaching machines are relatively simple as they only have to move the broach in a linear motion at a predetermined speed and provide a means for handling the broach automatically. Most machines are hydraulic, but a few specialty machines are mechanically driven.

- The machines are distinguished by whether their motion is horizontal or vertical. The choice of machine is primarily dictated by the stroke required. Vertical broaching machines rarely have a stroke longer than 60 in (1.5 m).
- Horizontal broaching machines are designed for pull broaching, surface broaching, continuous broaching, and rotary broaching. Pull style machines are basically vertical machines laid on the side with a longer stroke.
- Surface style machines hold the broach stationary while the workpieces are clamped into fixtures that are mounted on a conveyor system. Continuous style machines are similar to the surface style machines except adapted for internal broaching.
- Horizontal machines used to be much more common than vertical machines, however today they represent just 10% of all broaching machines purchased. Vertical machines are more popular because they take up less space.
- Broaching is often impossible without the specific broaching or keyway machines unless you have a system that can be used in conjunction with a modern machining centre or driven tooling lathe; these extra bits of equipment open up the possibility of producing keyways, splines and torx through one-hit machining.

15. Discuss

(a) Method of broaching operation

(b) Fixture used in broaching

(c) Material of broach.

On the basis of method of broaching the operation of broaching is classified as discussed below.

Pull Broaching

Workpiece is clamped to the broaching machine in stationary position and the broach is pulled through the work. Broaches are usually long and are held in a special head. Pull broaching is mostly used for internal broaching.

Push Broaching

Workpiece is held in the broaching machine in stationary position and broach is pushed through the portion of workpiece to be machined. Normally push broaching is done by hand and arbor presses (hydraulic press). This method is also recommended for internal broaching like for sizing and finishing the holes, cavities, and key ways.

Surface Broaching

Any one of two, either workpiece or the broach (tool) is kept moving and other is kept stationary. The method is widely used as surface finishing operation. In case of surface broaching, the broaching tool is specifically designed for the shape to be finished.

Continuous Broaching

In continuous broaching the broach is held stationary in the broaching machine and workpiece is moved continuously. The teeth of movement of the workpiece may be straight, horizontal or circular. This is generally used for broaching a large number of similar workpieces at a time.

Fixtures Used In Broaching

Fixtures plays important role in broaching operation. Fixtures are used for providing an accurate pre-decided movement to broach with proper clamping action. Accuracy and rigidity of fixture make the operation of broaching repeatable and fit for mass production. Functions of broaching fixture are summarized as given below:

- (a) Fixture holds the workpiece accurately and rigidity and moves it to the exact cutting position.
- (b) Guide the movement of the broach in pre-decided manner relative to the workpiece.
- (c) Fixture is also responsible to give feed motion to workpiece after completion of the cut.

Material of Broach

Common broach material is 18-4-1 stainless steel. As its name indicates, it has 4% chromium, 1% vanadium and 18% tungsten. This is corrosion and wear resistant steel. Carbide is also recommended for broach making, these broaches are used for broaching brittle material like cast iron in automobile industry. Inserted bit type and cemented carbide type broaches are also preferred to reduce the cost of broaches.

16. Surface integrity evaluation techniques.

Surface integrity evaluation techniques

At this point in time, definitive and complete sets of collated data on specific process and material combinations are quite rare. The General Electric Company is collecting surface integrity data in a separate encyclopedia. Three types of surface integrity evaluation programs have been developed to provide three increasingly deep levels of study. The MDS data includes the basic surface topography that is normal in assessing a machined surface and some of the metallurgical measurements. The SDS gives a measure of the impact on material properties and is considered the

basic data set for- correlation and comparisons. The EDS carries the investigation even deeper and includes specialized and environmentally related effects. The three levels are outlined as follows:

MINIMUM DATA SET OR SURFACE METALLOGRAPHY (MDS)

Surface roughness and texture or lay (photos and profile traces)

- Macrocracks
- Microhardness profile or map
- Microsection metallurgical assessment (1000X preferred)
- Microstructure transformation

Foreign or processing inclusions

- IGA, HAZ, Selective etch, etc
- Scanning electron microscope (SEMI photos (20, 200, 1000, 2000X preferred)

STANDARD DATA SET (SDS)

- Minimum data set
- Residual stress profile
- Fatigue strength (screening tests at room temp)

EXTENDED DATA SET (ED.5)

- Standard data set
- Stress corrosion tests
- Fatigue strength (design data)
- Other specially selected tests.

17. Define and discuss Surface Integrity.

Definition

Surface integrity is the sum of all of the elements that describe all the conditions existing on or at the surface of a piece of finished hardware. Surface integrity has two aspects. The first is surface topography which describes the roughness, lay or texture of the outermost layer of the work piece, i.e., its interface with the environment. The second is surface metallurgy which describes the nature of the altered layers below the surface with respect to the base or matrix material. It is the assessment of the impact of manufacturing processes on the properties of the workpiece material.

Surface integrity is defined by Dr. Kahles as, "The unimpaired or enhanced surface condition or properties of a material resulting from a controlled manufacturing process". In a broad sense, the concern is for surface quality. Surface integrity has two ingredients-those that relate to the surface topography and those that relate to the characteristics immediately below the surface, i.e., surface metallurgy.

Surface Integrity

Surface integrity reflects the properties of a material after it has been subject to some type of manufacturing process or modification. Engineers and product designers often plan projects based on the known characteristics of a particular metal. For example, these designers know that a specific steel alloy offers a set level of strength or hardness.

After the material has been modified, these original properties may no longer apply, as many manufacturing processes create a permanent change in the material. Surface integrity helps these individuals determine how a material will change under certain conditions, and what its new properties are compared to its old ones.

The surface integrity of any material is made up of two basic components. They include the topography and internal surface features of the product. Topography reflects changes on the exterior surface of a material, and includes things like smoothness, bumps or waves, pitting and cracks. Internal features address changes just below the outer surface, such as deformation and changes in strength or hardness. They do not include internal changes deep within the heart of a material, but rather in the layer just below the surface.

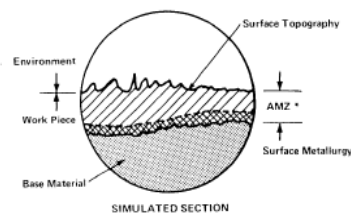

18. What are the Properties or characteristics of surface-engineered components including.

- ⇒ Improved corrosion resistance through barrier or sacrificial protection;
- ⇒ Improved oxidation and/or sulfidation resistance
- ⇒ Improved wear resistance;
- ⇒ Reduced friction energy losses;
- ⇒ Improved mechanical properties, for example, enhanced fatigue life, hardness or toughness
- ⇒ Improved electronic or electrical properties
- ⇒ Improved thermal insulation
- ⇒ Improved biological properties
- ⇒ Improved aesthetic appearance

19. Some Typical Defects of the Machined Surface Affecting its SI.

Various defects are caused by and produced during part manufacturing compromising SI. These defects can be classified as those of the original material and those imposed during manufacturing. Amongst many defects found in practice, the following are most common:

- ⇒ Cracks are external or internal separations with sharp outlines. Cracks requiring magnification of 10microns or higher to be seen by a naked eye are called microcracks.
- ⇒ Metallurgical transformation involves microstructural changes caused by temperature and high contact pressures. Included are phase transformations, re-crystallization, alloy depletion, decarburization, and molten and re-cast, re-solidified, or re-deposited material, as in electrical-discharge machining.
- ⇒ Residual stresses caused by process forces, deformations and temperatures.
- ⇒ Craters are shallow depressions.
- ⇒ Inclusions are small, non-metallic elements or compounds in the metal.
- ⇒ Intergranular attack is the weakening a grain boundary by liquid-metal embrittlement or corrosion.
- ⇒ Pits are shallow surface depressions, usually the result of chemical or physical attack.
- ⇒ Plastic deformation is a severe surface deformation caused by high stresses due to friction or tool in manufacturing.

UNIT V

CNC MACHINES

5.1 Numerical Control (NC) Machine Tools

Numerical Control (NC) refers to the method of controlling the manufacturing operation by means of directly inserted coded numerical instructions into the machine tool. It is important to realize that NC is not a machining method, rather, it is a concept of machine control. Although the most popular applications of NC are in machining, NC can be applied to many other operations, including welding, sheet metalworking, riveting, etc.

The major advantages of NC over conventional methods of machine control are as follows:

Higher precision

Machining of complex three-dimensional shapes

Better quality

Higher productivity

Multi-operational machining

Low operator qualification

5.2 Types of NC systems

Machine controls are divided into three groups,

Traditional numerical control (NC);

Computer numerical control (CNC);

Distributed numerical control (DNC).

The original numerical control machines were referred to as NC machine tool. They have “hardwired” control, whereby control is accomplished through the use of punched paper (or plastic) tapes or cards. Tapes tend to wear, and become dirty, thus causing misreadings. Many other problems arise from the use of NC tapes, for example the need to manually reload the NC tapes for each new part and the lack of program editing abilities, which increases the lead time. The end of NC tapes was the result of two competing developments, CNC and DNC.

CNC refers to a system that has a local computer to store all required numerical data. While CNC was used to enhance tapes for a while, they eventually allowed the use of other storage media, magnetic tapes and hard disks. The advantages of CNC systems include but are not limited to the possibility to store and execute a number of large programs (especially if a three or more dimensional machining of complex shapes is considered), to allow editing of programs, to execute cycles of machining commands, etc.

The development of CNC over many years, along with the development of local area networking, has evolved in the modern concept of DNC. Distributed numerical control is similar to CNC, except a remote computer is used to control a number of machines. An off-

ME8451

site mainframe host computer holds programs for all parts to be produced in the DNC

Department of Mechanical Engineering

ME8451

facility. Programs are downloaded from the mainframe computer, and then the local controller feeds instructions to the hardwired NC machine.

The recent developments use a central computer which communicates with local CNC computers (also called Direct Numerical Control)

Controlled axes

NC system can be classified on the number of directions of motion they are capable to control simultaneously on a machine tool. Each free body has six degree of freedom, three positive or negative translations along x, y, and z-axis, and three rotations clockwise or counter clockwise about these axes. Commercial NC systems are capable of controlling simultaneously two, two and half, three, four and five degrees of freedom, or axes. The NC systems which control three linear translations (3-axis systems), or three linear translations and one rotation of the worktable (4-axis systems) are the most common.

Although the directions of axes for a particular machine tool are generally agreed as shown in the figure, the coordinate system origin is individual for each part to be machined and has to be decided in the very beginning of the process of CNC part programming.

Point-to-point vs. continuous systems

The two major types of NC systems are (see the figure):

Point-to-point (PTP) system, and

Contouring system.

PTP is a NC system, which controls only the position of the components. In this system, the path of the component motion relative to the workpiece is not controlled. The travelling between different positions is performed at the traverse speed allowable for the machine tool and following the shortest way.

Contouring NC systems are capable of controlling not only the positions but also the component motion, i.e., the travelling velocity and the programmed path between the desired positions.

Computer numerical control (CNC)

Numerical control (NC) is the automation of machine tools that are operated by precisely programmed commands encoded on a storage medium, as opposed to controlled manually via hand wheels or levers, or mechanically automated via cams alone. Most NC today is computer numerical control (CNC), in which computers play an integral part of the control.

In modern CNC systems, end-to-end component design is highly automated using computer-aided design (CAD) and computer-aided manufacturing (CAM) programs. The programs produce a computer file that is interpreted to extract the commands needed to operate a particular machine via a post processor, and then loaded into the CNC machines for production. Since any particular component might require the use of a number of different tools – drills, saws, etc., modern machines often combine multiple tools into a single "cell". In other installations, a number of different machines are used with an external controller and human or robotic operators that move the component from machine to machine. In either

ME8451

case, the series of steps needed to produce any part is highly automated and produces a part that closely matches the original CAD design.



The first NC machines were built in the 1940s and 1950s, based on existing tools that were modified with motors that moved the controls to follow points fed into the system on punched tape. These early servomechanisms were rapidly augmented with analog and digital computers, creating the modern CNC machine tools that have revolutionized the machining processes.

Modern CNC mills differ little in concept from the original model built at MIT in 1952. Mills typically consist of a table that moves in the X and Y axes, and a tool spindle that moves in the Z (depth). The position of the tool is driven by motors through a series of step-down gears in order to provide highly accurate movements, or in modern designs, direct-drive stepper motor or servo motors. Open-loop control works as long as the forces are kept small enough and speeds are not too great. On commercial metalworking machines closed loop controls are standard and required in order to provide the accuracy, speed, and repeatability demanded.

As the controller hardware evolved, the mills themselves also evolved. One change has been to enclose the entire mechanism in a large box as a safety measure, often with additional safety interlocks to ensure the operator is far enough from the working piece for safe operation. Most new CNC systems built today are completely electronically controlled.

CNC-like systems are now used for any process that can be described as a series of movements and operations. These include laser cutting, welding, friction stir welding, ultrasonic welding, flame and plasma cutting, bending, spinning, hole-punching, pinning, gluing, fabric cutting, sewing, tape and fiber placement, routing, picking and placing (PnP), and sawing.

Mills

CNC mills use computer controls to cut different materials. They are able to translate programs consisting of specific number and letters to move the spindle to various locations and depths. Many use G-code, which is a standardized programming language that many CNC machines understand, while others use proprietary languages created by their manufacturers. These proprietary languages while often simpler than G-code are not transferable to other machines.

Lathes

Lathes are machines that cut spinning pieces of metal. CNC lathes are able to make fast, precision cuts using indexable tools and drills with complicated programs for parts that normally cannot be cut on manual lathes. These machines often include 12 tool holders and coolant pumps to cut down on tool wear. CNC lathes have similar control specifications to

ME8451

CNC mills and can often read G-code as well as the manufacturer's proprietary programming language.

Plasma cutters



CNC plasma cutting

Plasma cutting involves cutting a material using a plasma torch. It is commonly used to cut steel and other metals, but can be used on a variety of materials. In this process, gas (such as compressed air) is blown at high speed out of a nozzle; at the same time an electrical arc is formed through that gas from the nozzle to the surface being cut, turning some of that gas to plasma. The plasma is sufficiently hot to melt the material being cut and moves sufficiently fast to blow molten metal away from the cut.

Electric discharge machining

Electric discharge machining (EDM), sometimes colloquially also referred to as spark machining, spark eroding, burning, die sinking, or wire erosion, is a manufacturing process in which a desired shape is obtained using electrical discharges (sparks). Material is removed from the workpiece by a series of rapidly recurring current discharges between two electrodes, separated by a dielectric fluid and subject to an electric voltage. One of the electrodes is called the tool-electrode, or simply the "tool" or "electrode," while the other is called the workpiece-electrode, or "workpiece."

When the distance between the two electrodes is reduced, the intensity of the electric field in the space between the electrodes becomes greater than the strength of the dielectric (at least in some point(s)), which breaks, allowing current to flow between the two electrodes. This phenomenon is the same as the breakdown of a capacitor. As a result, material is removed from both the electrodes. Once the current flow stops (or it is stopped – depending on the type of generator), new liquid dielectric is usually conveyed into the inter-electrode volume enabling the solid particles (debris) to be carried away and the insulating properties of the dielectric to be restored. Adding new liquid dielectric in the inter-electrode volume is commonly referred to as flushing. Also, after a current flow, a difference of potential between the two electrodes is restored to what it was before the breakdown, so that a new liquid dielectric breakdown can occur.

Wire EDM

Also known as wire cutting EDM, wire burning EDM, or traveling wire EDM, this process uses spark erosion to machine or remove material with a traveling wire electrode from any electrically conductive material. The wire electrode usually consists of brass or zinc-coated brass material.

Sinker EDM

Sinker EDM, also called cavity type EDM or volume EDM, consists of an electrode and workpiece submerged in an insulating liquid—often oil but sometimes other dielectric fluids. The electrode and workpiece are connected to a suitable power supply, which generates an

ME8451

electrical potential between the two parts. As the electrode approaches the workpiece, dielectric breakdown occurs in the fluid forming a plasma channel) and a small spark jumps.

Water jet cutters

A water jet cutter, also known as a waterjet, is a tool capable of slicing into metal or other materials (such as granite) by using a jet of water at high velocity and pressure, or a mixture of water and an abrasive substance, such as sand. It is often used during fabrication or manufacture of parts for machinery and other devices. Waterjet is the preferred method when the materials being cut are sensitive to the high temperatures generated by other methods. It has found applications in a diverse number of industries from mining to aerospace where it is used for operations such as cutting, shaping, carving, and reaming.

Other CNC tools: Many other tools have CNC variants, including:

- Drills
- EDMs
- Embroidery machines
- Lathes
- Milling machines
- Wood routers
- Sheet metal works (Turret punch)
- Wire bending machines
- Hot-wire foam cutters
- Plasma cutters
- Water jet cutters
- Laser cutting
- Oxy-fuel
- Surface grinders
- Cylindrical grinders
- 3D Printing
- Induction hardening machines
- submerged welding
- knife cutting
- glass cutting

5.3 Programming Fundamentals CNC

Fanuc G-Code List (Lathe)

G code	Description
G00	Rapid traverse
G01	Linear interpolation
G02	Circular interpolation CW
G03	Circular interpolation CCW
G04	Dwell
G09	Exact stop

ME8451

G10	Programmable data input
G20	Input in inch
G21	Input in mm
G22	Stored stroke check function on
G23	Stored stroke check function off
G27	Reference position return check
G28	Return to reference position
G32	Thread cutting
G40	Tool nose radius compensation cancel
G41	Tool nose radius compensation left
G42	Tool nose radius compensation right
G70	Finish machining cycle
G71	Turning cycle
G72	Facing cycle
G73	Pattern repeating cycle
G74	Peck drilling cycle
G75	Grooving cycle
G76	Threading cycle
G92	Coordinate system setting or max. spindle speed setting
G94	Feed Per Minute
G95	Feed Per Revolution
G96	Constant surface speed control
G97	Constant surface speed control cancel

Fanuc G-Code List (Mill)

G code	Description
G00	Rapid traverse
G01	Linear interpolation
G02	Circular interpolation CW
G03	Circular interpolation CCW
G04	Dwell
G17	X Y plane selection
G18	Z X plane selection
G19	Y Z plane selection
G28	Return to reference position

ME8451

G30	2nd, 3rd and 4th reference position return
G40	Cutter compensation cancel
G41	Cutter compensation left
G42	Cutter compensation right
G43	Tool length compensation + direction
G44	Tool length compensation – direction
G49	Tool length compensation cancel
G53	Machine coordinate system selection
G54	Workpiece coordinate system 1 selection
G55	Workpiece coordinate system 2 selection
G56	Workpiece coordinate system 3 selection
G57	Workpiece coordinate system 4 selection
G58	Workpiece coordinate system 5 selection
G59	Workpiece coordinate system 6 selection
G68	Coordinate rotation
G69	Coordinate rotation cancel
G73	Peck drilling cycle
G74	Left-spiral cutting circle
G76	Fine boring cycle
G80	Canned cycle cancel
G81	Drilling cycle, spot boring cycle
G82	Drilling cycle or counter boring cycle
G83	Peck drilling cycle
G84	Tapping cycle
G85	Boring cycle
G86	Boring cycle
G87	Back boring cycle
G88	Boring cycle
G89	Boring cycle
G90	Absolute command
G91	Increment command
G92	Setting for work coordinate system or clamp at maximum spindle speed
G98	Return to initial point in canned cycle
G99	Return to R point in canned cycle

ME8451**Fanuc M-Code List (Lathe)**

M code	Description
M00	Program stop
M01	Optional program stop
M02	End of program
M03	Spindle start forward CW
M04	Spindle start reverse CCW
M05	Spindle stop
M08	Coolant on
M09	Coolant off
M29	Rigid tap mode
M30	End of program reset
M40	Spindle gear at middle
M41	Low Gear Select
M42	High Gear Select
M68	Hydraulic chuck close
M69	Hydraulic chuck open
M78	Tailstock advancing
M79	Tailstock reversing
M94	Mirrorimage cancel
M95	Mirrorimage of X axis
M98	Subprogram call
M99	End of subprogram

Fanuc M-Code List (Mill)

M code	Description
M00	Program stop
M01	Optional program stop
M02	End of program
M03	Spindle start forward CW
M04	Spindle start reverse CCW
M05	Spindle stop
M06	Tool change
M07	Coolant ON – Mist coolant/Coolant thru spindle
M08	Coolant ON – Flood coolant

ME8451

M09	Coolant OFF
M19	Spindle orientation
M28	Return to origin
M29	Rigid tap
M30	End of program (Reset)
M41	Low gear select
M42	High gear select
M94	Cancel mirrorimage
M95	Mirrorimage of X axis
M96	Mirrorimage of Y axis
M98	Subprogram call
M99	End of subprogram

5.4 Manual Part Programming**Lathe**

G02 G03 G Code Circular Interpolation

G02 G Code Clock wise Circular Interpolation.

G03 G Code Counter Clock wise Circular Interpolation.

There are multiple articles/cnc program examples about G code circular interpolation, here is the list of few articles so that cnc machinists can easily navigate through different cnc programming articles.

G02 G03 G Code Example CNC Programs (G code Arc Examples)

- CNC Circular Interpolation Tutorial G02 G03
- Fanuc CNC Lathe Programming Example
- CNC Programming Example G Code G02 Circular Interpolation Clockwise
- Fanuc G20 Measuring in Inches with CNC Program Example
- CNC Arc Programming Exercise
- CNC Programming for Beginners a CNC Programming Example
- CNC Lathe Programming Example

Here is a new CNC programming examples which shows the use of G02 G03 G code circular interpolation.

G02 G03 G Code Example Program

ME8451

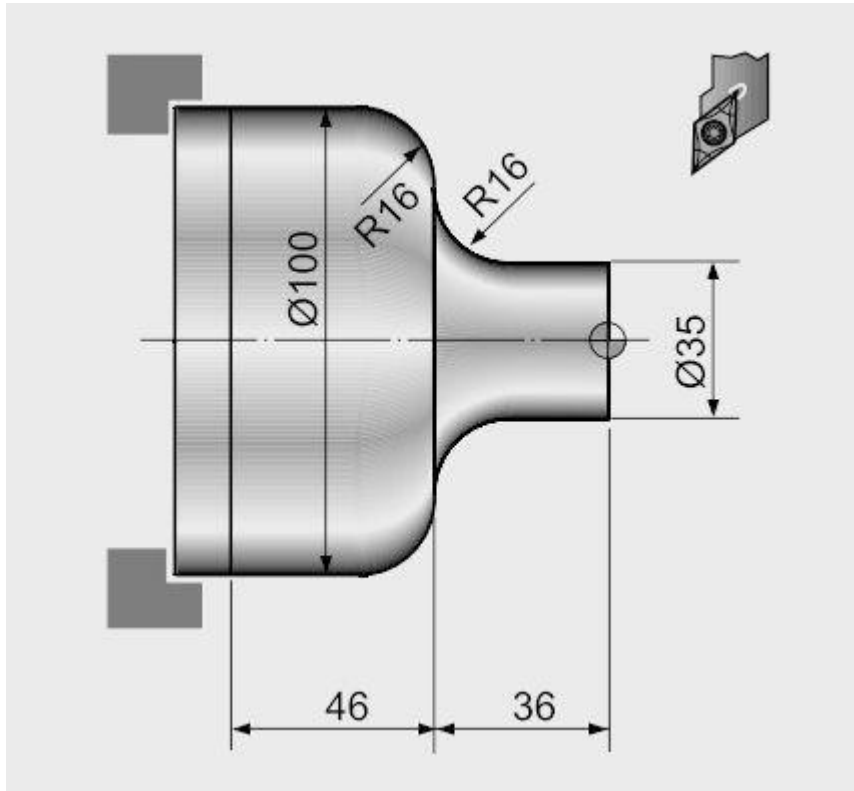

G02 G03 G Code Circular Interpolation Example Program

```

N20 G50 S2000 T0300
G96 S200 M03
G42 G00 X35.0 Z5.0 T0303 M08
G01 Z-20.0 F0.2
G02 X67.0 Z-36.0 R16.0
G01 X68.0 :
G03 X100.0 Z-52.0 R16.0
G01 Z-82.0
G40 G00 X200.0 Z200.0 M09 T0300
M30
    
```

G Code G02 G03 I & K Example Program

G02 G03 G Code Circular Interpolation can be programmed in two ways,

```

G02 X... Z... R...
G02 X... Z... I... K...
    
```

The below is the same cnc program but this version uses I & K with G02 G03 G code.

```

N20 G50 S2000 T0300
G96 S200 M03
G42 G00 X35.0 Z5.0 T0303 M08
G01 Z-20.0 F0.2
G02 X67.0 Z-36.0 I16.0 K0
G01 X68.0 :
G03 X100.0 Z-52.0 I0 K-16.0
G01 Z-82.0
G40 G00 X200.0 Z200.0 M09 T0300
    
```

ME8451

M30

G20 Turning Cycle Format for Straight Turning

G20 X... Z... F...

or

G20 U... W... F...

X – Diameter to be cut (absolute).

Z – End point in z-axis (absolute).

F – Feed-rate.

U – Diameter to be cut (incremental).

W – End point in z-axis (incremental).

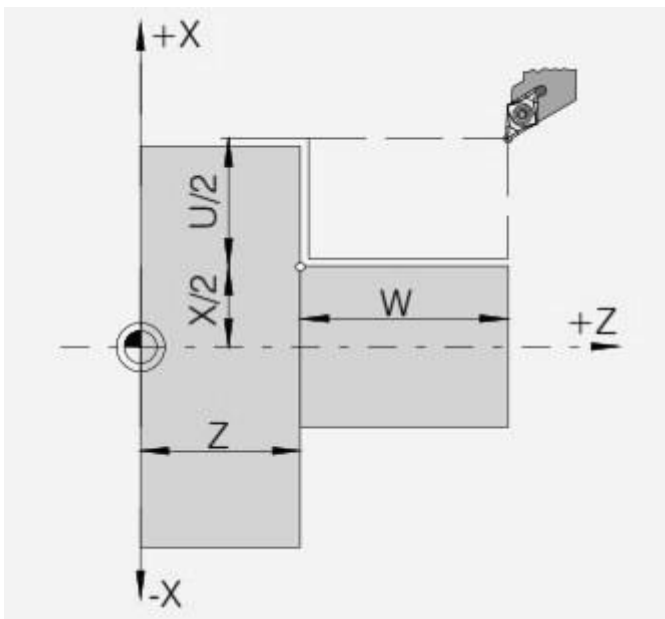

G20 Turning Cycle – CNC Lathe Fanuc 21 TB

G20 Turning Cycle Format for Taper Turning

G20 X... Z... R... F...

or

G20 U... W... R... F...

X – Diameter to be cut (absolute).

Z – End point in z-axis (absolute).

R – Incremental taper dimension in X with direction (+/-)

F – Feed-rate.

U – Diameter to be cut (incremental).

W – End point in z-axis (incremental).

As cnc machinists can use X or U value for the contour value, same way Z or W can be used or you can even mix both absolute (X, Z) and incremental (U, W) values.

G20 Turning Cycle Example CNC Program Code

ME8451

```
G96 S200 M03
G00 X56.0 Z2.0
G20 X51.0 W-20.0 F0.25
X46.0
X41.0
X36.0
X31.0
X30.0
G00 X100 Z100
M30
```

CNC Program Code Explanation

As you can see in the above cnc program code,
 Tool is at X56 Z2 point,
 First cut is made at X51 and tool travels W-20 in Z-axis.
 Second cut is made at X46
 Third cut is made at X41
 ...
 Last cut is made at X30

G20 Turning Cycle Function

As if you study the above cnc program code you will notice that,
 1 – with G20 both absolute (X51.0) and incremental (W-20.0) values are used to make cuts.
 2 – If above code also shows a very powerful functionality of G20 turning cycle which is that a cnc machinist can control depth-of-cut of every pass of G20 turning cycle which is impossible to achieve with other Turning Canned Cycle like G71 Rough Turning Cycle. So you will notice first five-cuts are of 5mm deep but the last one is just 1mm deep.

Cancellation of G20 Turning Cycle

G20 turning cycle is a modal G-code.
 “Modal” G-code meaning that they stay in effect until they are cancelled or replaced by a contradictory G code.
 It means G20 turning cycle remains active until another motion command is given like G00, G01 etc. As in above cnc program example G20 G code is cancelled with G00 G code.

Milling

Programming

```
G72.1 P... L... X... Y... R...
```

Parameters

Parameter	Description
P	Subprogram number
L	Number of times the operation is repeated
X	Center of rotation on the X axis

ME8451

Y	Center of rotation on Y axis
R	Angular displacement (a positive value indicates a counter clockwise angular displacement. Specify an incremental value.)

G-Code Data

Modal/Non-Modal	G-Code Group
Non-Modal	00

Programming Notes

Notes

1. In the G72.1 block, addresses other than P, L, X, Y and R are ignored.
2. P, X, Y and R must always be specified.
3. If L is not specified, the figure is copied once.
4. The coordinate of the center of rotation is handled as an absolute value even if it is specified in the incremental mode.
5. Specify an increment in the angular displacement at address R. The angular displacement (degree) for the Nth figure is calculated as follows: $R \times (N-1)$.

First block of the subprogram

Always specify a move command in the first block of a subprogram that performs a rotational copy. If the first block contains only the program number such as O00001234; and does not have a move command, movement may stop at the start point of the figure made by the n-th (n = 1,2, 3, ...) copying.

Example of an incorrect program

```
O00001234 ;
G00 G90 X100.0 Y200.0 ;
;
;
M99 ;
```

Example of a correct program

```
O00001000 G00 G90 X100.0 Y200.0 ;
;
;
M99 ;
```

Limitation

Specifying two or more commands to copy a figure

G72.1 cannot be specified more than once in a subprogram for making a rotational copy (If this is attempted, alarmPS0900 will occur).

In a subprogram that specifies rotational copy, however, linear copy (G72.2) can be specified. Similarly, in a subprogram that specifies linear copy, rotational copy can be specified.

Commands that must not be specified

Within a program that performs a rotational copy, the following must not be specified:

- _____ Command for changing the selected plane (G17 to G19)
- _____ Command for specifying polar coordinates (G16)
- _____ Reference position return command(G28)
- _____ Axis switching

ME8451

- _____ Coordinate system rotation (G68)
- _____ scaling (G51)
- _____ programmable mirror image (G51.1)

The command for rotational copying can be specified after a command for coordinate system rotation, scaling, or programmable mirror image is executed.

Single

block

Single-block stops are not performed in a block with G721.1 or G72.2.

G72.1 Programming Example

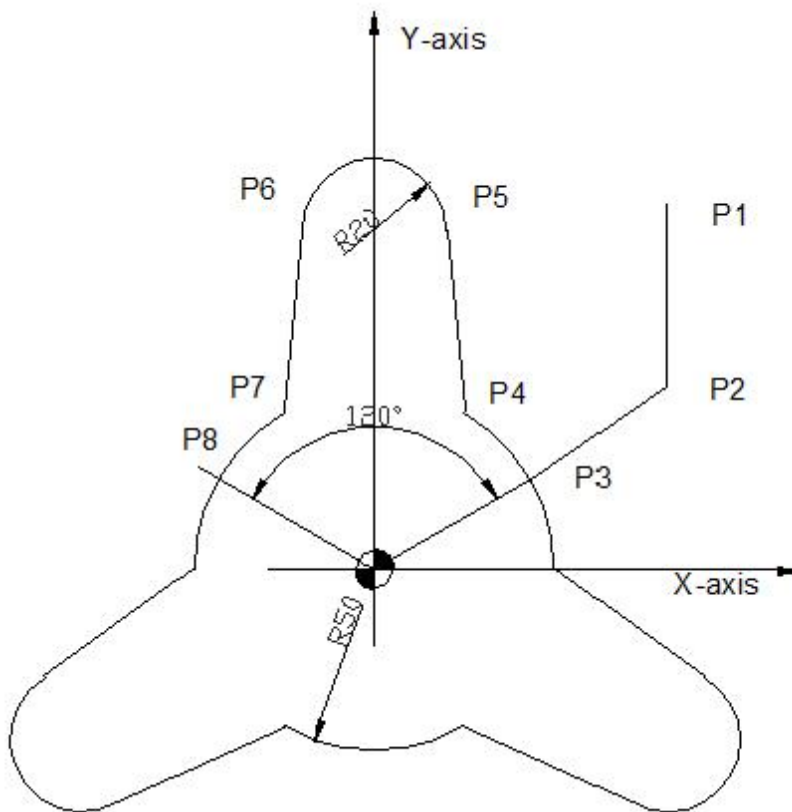

Main program

```
O1000 ;
N10 G90 G00 X80. Y100. ;      (P1)
N20 Y50. ;                    (P2)
N30 G01 G17 G42 X43.301 Y25. D01 F100 ;(P3)
N40 G72.1 P1100 L3 X0 Y0 R120. ;
N50 G90 G40 G01 X80. Y50. ;    (P2)
N60 G00 X80. Y100. ;         (P1)
N70 M30 ;
```

ME8451

Sub program

```
O1100 G91 G03 X-18.301 Y18.301 R50. ; (P4)
N100 G01 X-5. Y50. ; (P5)
N200 G03 X-40. I-20. ; (P6)
N300 G01 X-5. Y-50. ; (P7)
N400 G03 X-18.301 Y-18.301 R50. ; (P8)
N500 M99 ;
```

5.5 Micromachining

Superfinishing, a metalworking process for producing very fine surface finishes

Various micro electro mechanical systems

Bulk micromachining

Surface micromachining

High-aspect-ratio microstructure technologies

Bulk micromachining is a process used to produce micro machinery or micro electro mechanical systems (MEMS).

Unlike surface micromachining, which uses a succession of thin film deposition and selective etching, bulk micromachining defines structures by selectively etching inside a substrate. Whereas surface micromachining creates structures *on top* of a substrate, bulk micromachining produces structures *inside* a substrate.

Usually, silicon wafers are used as substrates for bulk micromachining, as they can be anisotropically wet etched, forming highly regular structures. Wet etching typically uses alkaline liquid solvents, such as potassium hydroxide (KOH) or tetramethylammonium hydroxide (TMAH) to dissolve silicon which has been left exposed by the photolithography masking step. These alkali solvents dissolve the silicon in a highly anisotropic way, with some crystallographic orientations dissolving up to 1000 times faster than others. Such an approach is often used with very specific crystallographic orientations in the raw silicon to produce V-shaped grooves. The surface of these grooves can be atomically smooth if the etch is carried out correctly, and the dimensions and angles can be precisely defined.

Bulk micromachining starts with a silicon wafer or other substrates which is selectively etched, using photolithography to transfer a pattern from a mask to the surface. Like surface micromachining, bulk micromachining can be performed with wet or dry etches, although the most common etch in silicon is the anisotropic wet etch. This etch takes advantage of the fact that silicon has a crystal structure, which means its atoms are all arranged periodically in lines and planes. Certain planes have weaker bonds and are more susceptible to etching. The etch results in pits that have angled walls, with the angle being a function of the crystal orientation of the substrate. This type of etching is inexpensive and is generally used in early, low-budget research.

Unlike Bulk micromachining, where a silicon substrate (wafer) is selectively etched to produce structures, surface micromachining builds microstructures by deposition and etching of different structural layers on top of the substrate. Generally polysilicon is commonly used as one of the layers and silicon dioxide is used as a sacrificial layer which is removed or etched out to create the necessary void in the thickness direction. Added layers are generally

ME8451

very thin with their size varying from 2-5 Micro metres. The main advantage of this machining process is the possibility of realizing monolithic microsystems in which the electronic and the mechanical components(functions) are built in on the same substrate. The surface micromachined components are smaller compared to their counterparts, the bulk micromachined ones.

As the structures are built on top of the substrate and not inside it, the substrate's properties are not as important as in bulk micromachining, and the expensive silicon wafers can be replaced by cheaper substrates, such as glass or plastic. The size of the substrates can also be much larger than a silicon wafer, and surface micromachining is used to produce TFTs on large area glass substrates for flat panel displays. This technology can also be used for the manufacture of thin film solar cells, which can be deposited on glass, but also on PET substrates or other non-rigid materials.

HARMST is an acronym for **H**igh **A**spect **R**atio **M**icrostructure **T**echnology that describes fabrication technologies, used to create high-aspect-ratio microstructures with heights between tens of micrometers up to a centimeter and aspect ratios greater than 10:1. Examples include the LIGA fabrication process, advanced silicon etch, and deep reactive ion etching.

5.6 Water Machining

A water jet cutter, also known as a waterjet or waterjet, is an industrial tool capable of cutting a wide variety of materials using a very high-pressure jet of water, or a mixture of water and an abrasive substance. The term abrasive jet refers specifically to the use of a mixture of water and abrasive to cut hard materials such as metal or granite, while the terms pure waterjet and water-only cutting refer to waterjet cutting without the use of added abrasives, often used for softer materials such as wood or rubber. Waterjet cutting is often used during fabrication of machine parts. It is the preferred method when the materials being cut are sensitive to the high temperatures generated by other methods. Waterjet cutting is used in various industries, including mining and aerospace, for cutting, shaping, and reaming.



Water jet CNC cutting Machine

While using high-pressure water for erosion dates back as far as the mid-1800s with hydraulic mining, it was not until the 1930s that narrow jets of water started to appear as an industrial cutting device. In 1933, the Paper Patents Company in Wisconsin developed a paper metering, cutting, and reeling machine that used a diagonally moving waterjet nozzle to cut a horizontally moving sheet of continuous paper. These early applications were at a low pressure and restricted to soft materials like paper.

ME8451

Waterjet technology evolved in the post-war era as researchers around the world searched for new methods of efficient cutting systems. In 1956, Carl Johnson of Durox International in Luxembourg developed a method for cutting plastic shapes using a thin stream high-pressure waterjet, but those materials, like paper, were soft materials.^[3] In 1958, Billie Schwacha of North American Aviation developed a system using ultra-high-pressure liquid to cut hard materials.^[4] This system used a 100,000 psi (690 MPa) pump to deliver a hypersonic liquid jet that could cut high strength alloys such as PH15-7-MO stainless steel. Used as a honeycomb laminate on the Mach 3 North American XB-70 Valkyrie, this cutting method resulted in delaminating at high speed, requiring changes to the manufacturing process. While not effective for the XB-70 project, the concept was valid and further research continued to evolve waterjet cutting. In 1962, Philip Rice of Union Carbide explored using a pulsing waterjet at up to 50,000 psi (345 MPa) to cut metals, stone, and other materials. Research by S.J. Leach and G.L. Walker in the mid-1960s expanded on traditional coal waterjet cutting to determine ideal nozzle shape for high-pressure waterjet cutting of stone, and Norman Franz in the late 1960s focused on waterjet cutting of soft materials by dissolving long chain polymers in the water to improve the cohesiveness of the jet stream. In the early 1970s, the desire to improve the durability of the waterjet nozzle led Ray Chadwick, Michael Kurko, and Joseph Corriveau of the Bendix Corporation to come up with the idea of using corundum crystal to form a waterjet orifice, while Norman Franz expanded on this and created a waterjet nozzle with an orifice as small as 0.002 inches (0.05 mm) that operated at pressures up to 70,000 psi (483 MPa). John Olsen, along with George Hurlburt and Louis Kapcsandy at Flow Research (later Flow Industries), further improved the commercial potential of the waterjet by showing that treating the water beforehand could increase the operational life of the nozzle.

Abrasive waterjet

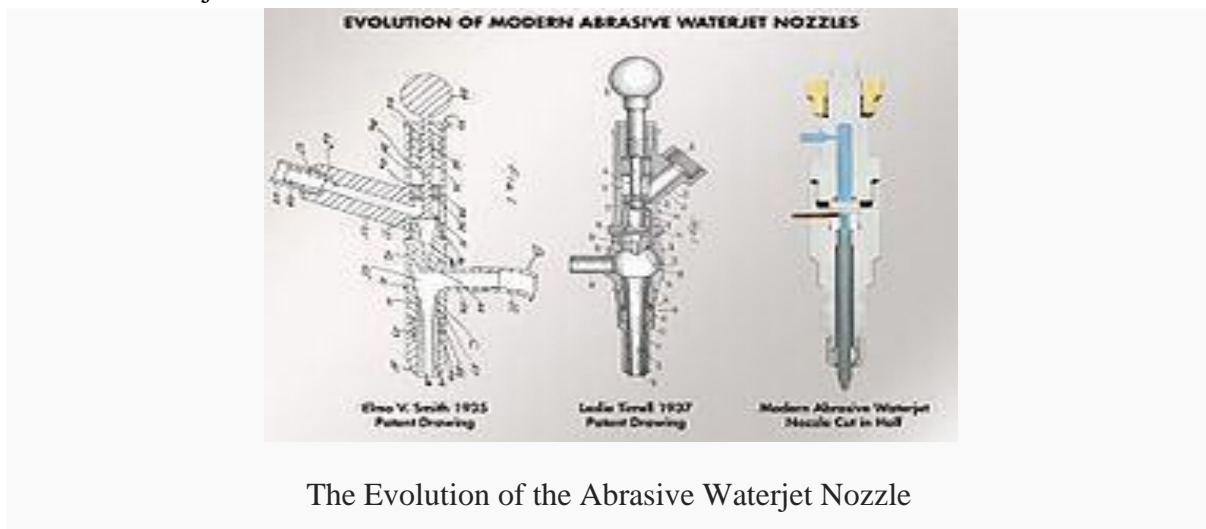

The Evolution of the Abrasive Waterjet Nozzle

While cutting with water is possible for soft materials, the addition of an abrasive turned the waterjet into a modern machining tool for all materials. This began in 1935 when the idea of adding an abrasive to the water stream was developed by Elmo Smith for the liquid abrasive blasting. Smith's design was further refined by Leslie Tirrell of the Hydroblast Corporation in 1937, resulting in a nozzle design that created a mix of high-pressure water and abrasive for the purpose of wet blasting. Producing a commercially viable abrasive waterjet nozzle for precision cutting came next by Dr. Mohamed Hashish who invented and led an engineering research team at Flow Industries to develop the modern abrasive waterjet cutting

ME8451

technology. Dr. Hashish, who also coined the new term "Abrasive Waterjet" AWJ, and his team continued to develop and improve the AWJ technology and its hardware for many applications which is now in over 50 industries worldwide. A most critical development was creating a durable mixing tube that could withstand the power of the high-pressure AWJ, and it was Boride Products (now Kennametal) development of their ROCTEC line of ceramic tungsten carbide composite tubes that significantly increased the operational life of the AWJ nozzle. Current work on AWJ nozzles is on micro abrasive waterjet so cutting with jets smaller than 0.015 inch in diameter can be commercialized.

Applications

Because the nature of the cutting stream can be easily modified the water jet can be used in nearly every industry; there are many different materials that the water jet can cut. Some of them have unique characteristics that require special attention when cutting.

Materials commonly cut with a water jet include rubber, foam, plastics, leather, composites, stone, tile, metals, food, paper and much more. Materials that cannot be cut with a water jet are tempered glass, diamonds and certain ceramics. Water is capable of cutting material over eighteen inches (45 cm) thick.